

# KTM DUKE 690 SMC

year of production: ALL

product code: SR219



Assembly position (BOTH SIDES)

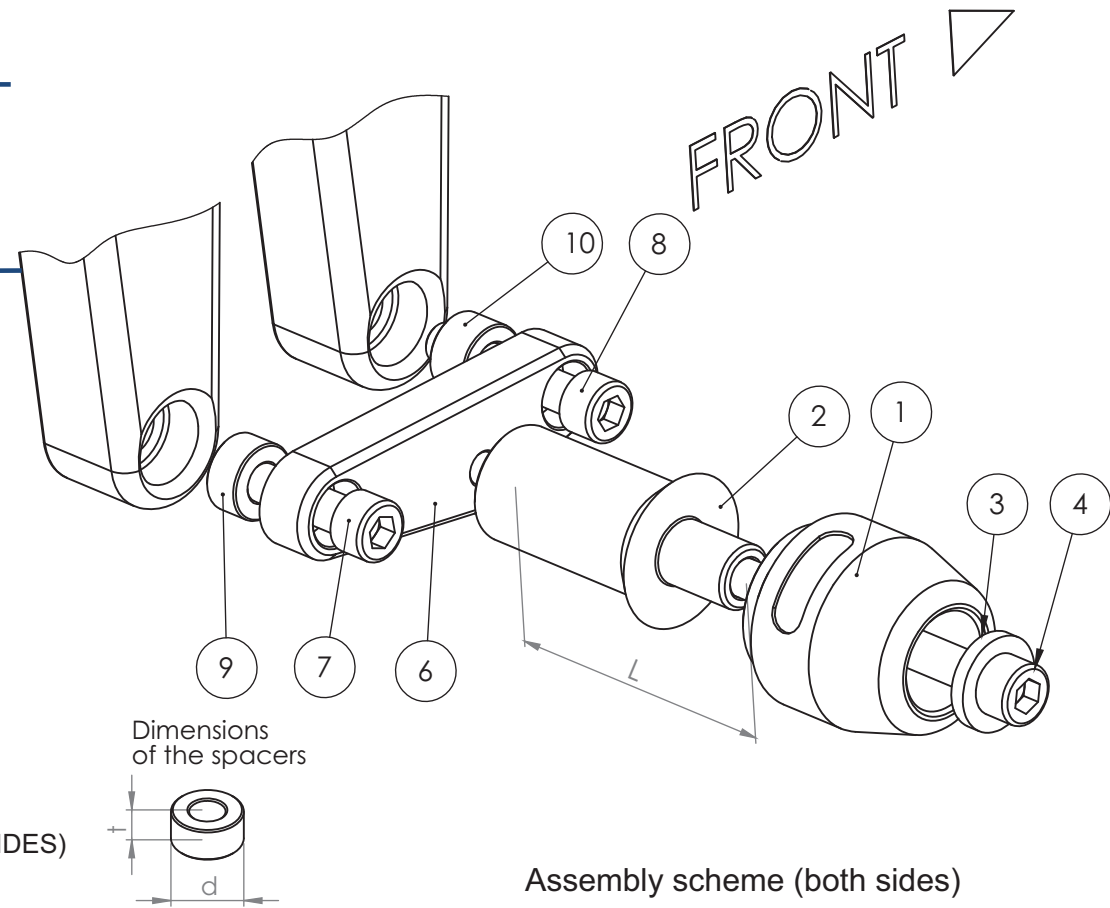

Assembly scheme (both sides)

### Assembly instructions

1. Please check the assembly positions on the image above. Remove the original bolts indicated with the arrow on the image above.
2. Replace the original bolts with the new mounting bolts (parts #7, #8), spacers (parts #9, #10) and metal adapters (parts #6) and put these parts in the right order shown on the assembly scheme on the right page. Put the adapters (parts #6) in the right positions according to the assembly scheme.
3. Assemble the sliders, round cylindrical body, the bolts, steel sleeve and the spacers (parts #1, #2, #3, #4 and #5) according to the drawing on the right page. Put them into the threaded holes in the adapter (part #6).

We suggest to use the threadlocker (eg. Loctite®) to make sure that the vibrations of the engine do not loosen the bolts.

Part #	Part name	Left side (as You sit on the motorbike)	Right side
1	Slider	1 pcs.	1 pcs.
2	Round cylindrical body	L = 80 mm	L = 80 mm
3	Steel sleeve	1 pcs.	1 pcs.
4	Allen bolt (8,8 class)	M10x140 mm	M10x140 mm
5	Spacer	t = 20 mm, d = 15 mm	t = 20 mm, d = 15 mm
6	Adapter	Steel flat bracket	Steel flat bracket
7	Mounting bolt 1	M10x40 mm	M10x50 mm
8	Mounting bolt 2	M10x40 mm	M10x50 mm
9	Spacer 1	t = 20 mm, d = 10 mm	t = 20 mm, d = 15 mm
10	Spacer 2	t = 20 mm, d = 10 mm	t = 20 mm, d = 15 mm
11	Nut	-	-
12	Washer	2 pcs. of M10 washer to be put under the M10 mounting bolts' heads	2 pcs. of M10 washer to be put under the M10 mounting bolts' heads

Legal note. This product is a professional accessory to be used on the race track. Neither manufacturer, nor Seller take responsibility for any damages occurred despite of using protective accessories.

Vortex puts everything within reach.

Our website offers you a wide variety of motorcycle frame & body at affordable prices.