

V3 FRAME SLIDERS KIT 2.0

DUCATI SCRAMBLER

year of production: **ALL**

product code: SR209



Assembly position
(both sides)

Assembly instructions

1. Remove the original bolts indicated with the arrows on the assembly position scheme above.
2. Replace the original bolt by the new threaded rod (part #7), the spacers (parts #9) and adapters (part #6) according to the scheme on the right page. Put the adapters (part #6) in the right position according to the drawing on the right page.
3. Assemble the slider, round cylindrical body, the bolt and the steel sleeve (parts #1, #2, #3 and #4) according to the drawing on the right page. Put them into the threaded hole in adapter (part #6).
4. Same operation is required in another side of the motorbike.
We suggest to use the threadlocker (eg. Loctite®) to make sure that the vibrations of the engine do not loosen the bolts.

Legal note. This product is a professional accessory to be used on the race track. Neither manufacturer, nor Seller take responsibility for any damages occurred despite of using protective accessories.

Vortex puts everything within reach.

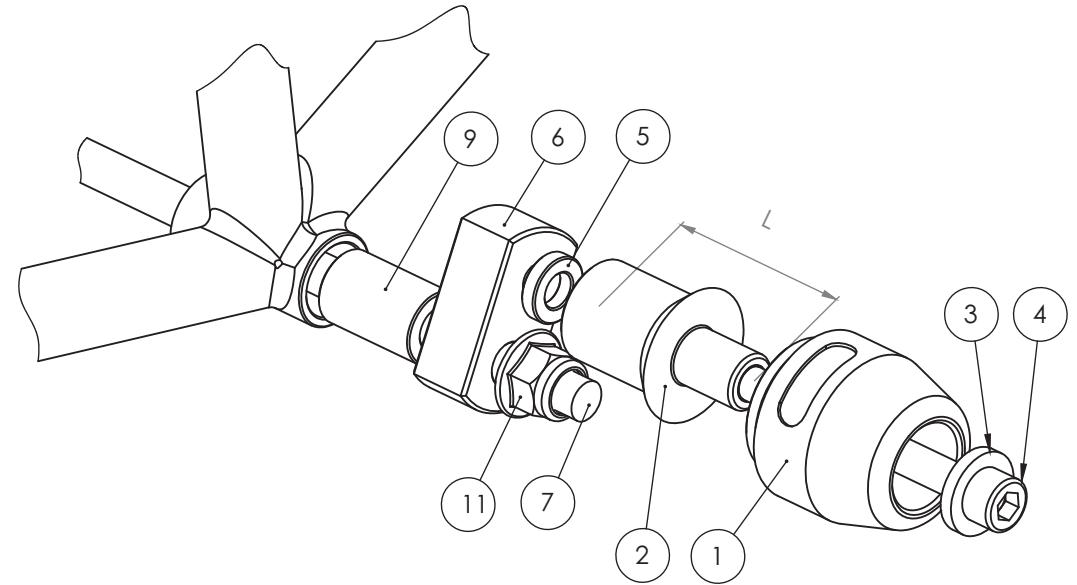

Dimensions of the sleeves:

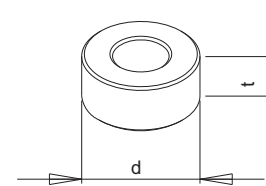

Assembly position (both sides)

Part #	Part name	Left side (as You sit on the motorbike)	Right side
1	Slider	1 pcs.	1 pcs.
2	Round cylindrical body	L = 40 mm	L = 45 mm
3	Steel sleeve	1 pcs.	1 pcs.
4	Allen bolt (8,8 class)	M10x60 mm	M10x70 mm
5	Spacer	t = 20 mm, d = 5 mm	t = 20 mm, d = 5 mm
6	Adapter	Aluminium	Aluminium
7	Mounting bolt 1	M12x395 mm	
8	Mounting bolt 2	-	-
9	Spacer 1	t = 20 mm, d = 50 mm	t = 20 mm, d = 45 mm
10	Spacer 2	-	-
11	Nut	M12, 1 pcs.	M12, 1 pcs.
12	Washer	-	-

Our website offers you a wide variety of motorcycle frame & body at affordable prices.