

V3 FRAME SLIDERS KIT 2.0

YAMAHA YZF R1

year of production: '09-'14

product code: SR179

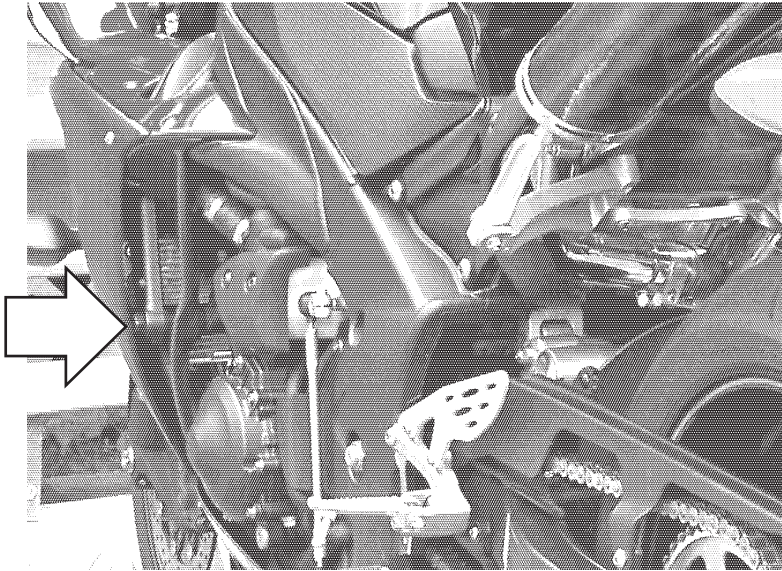

Assembly position
(both sides)

Assembly instructions

1. Remove the fairings on both sides.
 2. Please check the assembly positions on the image above. Remove the original bolts indicated with the arrow on the image above.
 3. Replace the original bolts with the new mounting bolts (parts #7), spacers (parts #9) and metal adapters (parts #6) and put these parts in the right order shown on the assembly scheme on the right page. Put the adapters (parts #6) in the right positions according to the assembly scheme. Please use the original spacer under the frame on the left side.
 4. Please assemble the fairings.
 7. Assemble the sliders, round cylindrical body, the bolts, steel sleeve and the spacers (parts #1, #2, #3 and #4) according to the drawing on the right page. Put them into the threaded holes in the adapter (part #6).
- We suggest to use the threadlocker (eg. Loctite®) to make sure that the vibrations of the engine do not loosen the bolts.

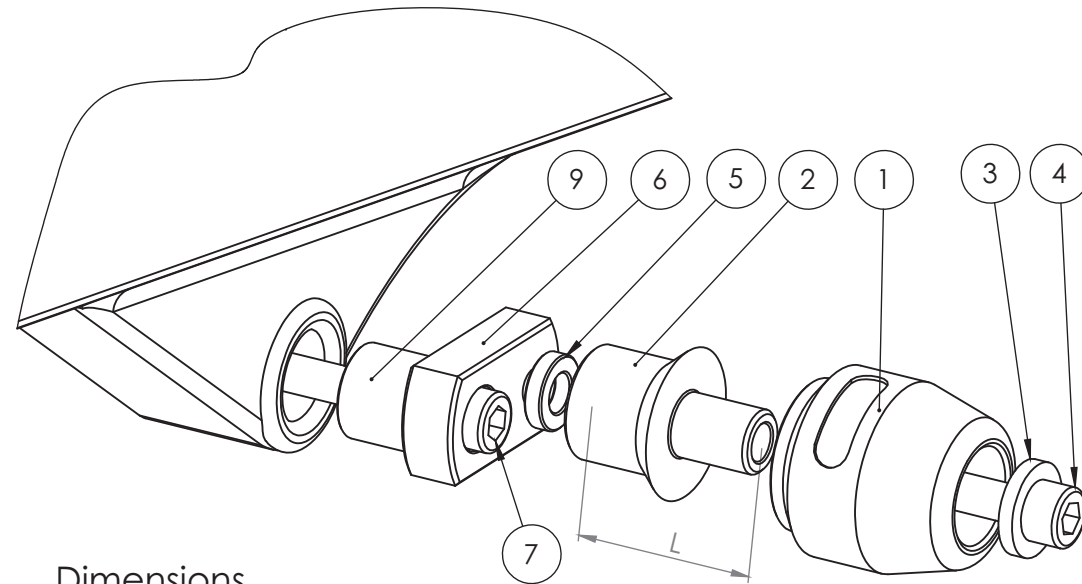

Dimensions
of the spacers

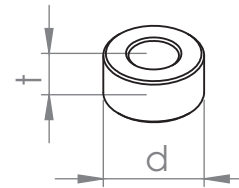

Assembly scheme (both sides)

Part #	Part name	Left side (as You sit on the motorbike)	Right side
1	Slider	1 pcs.	1 pcs.
2	Round cylindrical body	L = 50 mm	L = 60 mm
3	Steel sleeve	1 pcs.	1 pcs.
4	Allen bolt (8,8 class)	M10x70 mm	M10x80 mm
5	Spacer	-	-
6	Adapter	Aluminium (milled)	Aluminium (flat)
7	Mounting bolt 1	M12x1,25x120 (Hex)	M12x1,25x60 (Hex)
8	Mounting bolt 2	-	-
9	Spacer 1	t = 20 mm, d = 10 mm	-
10	Spacer 2	-	-
11	Nut	-	-
12	Washer	-	-

Legal note. This product is a professional accessory to be used on the race track. Neither manufacturer, nor Seller take responsibility for any damages occurred despite of using protective accessories.

Our website offers you a wide variety of motorcycle frame & body at affordable prices.