

V3 FRAME SLIDERS KIT 2.0

SUZUKI GSX-R 1000

year of production: '09-'15

product code: SR162

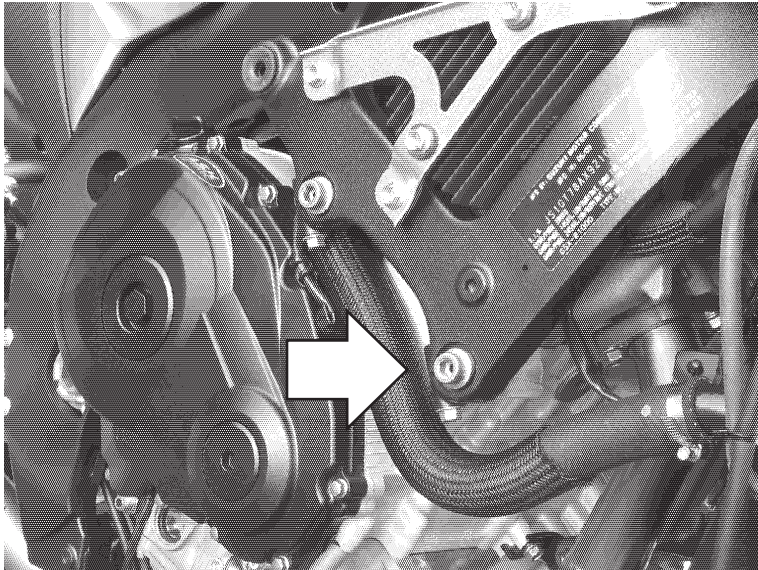

Assembly position
(Both sides)

Assembly instructions

1. Remove the fairings on both sides.
2. Please check the assembly positions on the image above. Remove the original bolts indicated with the arrow on the image above.
3. Replace the original bolts with the new mounting bolts (parts #7), spacers (parts #9) and metal adapters (parts #6) and put these parts in the right order shown on the assembly scheme on the right page. Put the adapters (parts #6) in the right positions according to the assembly scheme.
4. Mark the positions of the holes on the fairings. The correct positions are opposite to the threaded holes in the adapters (parts #6).
5. Drill the holes in the fairings. We suggest to drill small holes first (eg. 0,20" in diameter). Then check if the holes are in correct positions by putting the fairings on. If the positions of the holes are correct, drill the final holes. Final holes should be ca. 1,3" in diameter.
6. Please assemble the fairings.
7. Assemble the sliders, round cylindrical body, the bolts, steel sleeve and the spacers (parts #1, #2, #3 and #4) according to the drawing on the right page. Put them into the threaded holes in the adapter (part #6).

We suggest to use the threadlocker (eg. Loctite®) to make sure that the vibrations of the engine do not loosen the bolts.

Vortex puts everything within reach.

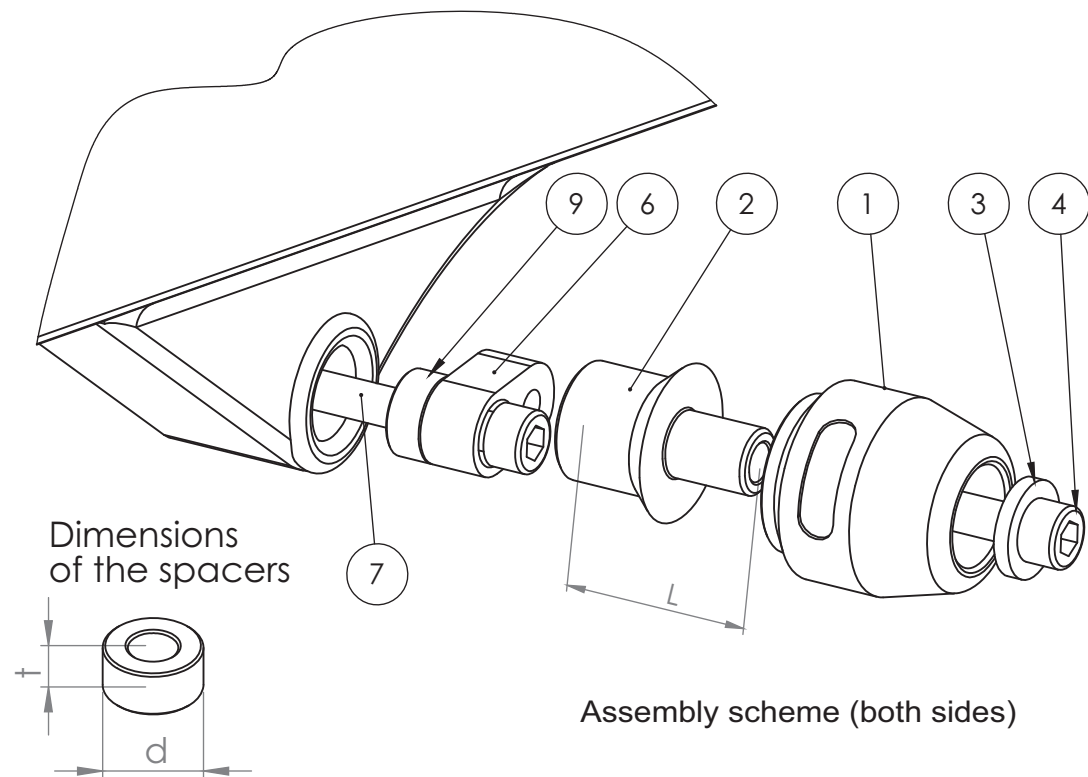

Assembly scheme (both sides)

Part #	Part name	Left side (as You sit on the motorbike)	Right side
1	Slider	1 pcs.	1 pcs.
2	Round cylindrical body	L = 40 mm	L = 30 mm
3	Steel sleeve	1 pcs.	1 pcs.
4	Allen bolt (8,8 class)	M10x60 mm	M10x50 mm
5	Spacer	-	-
6	Adapter	Steel	Steel
7	Mounting bolt 1	M10x1,25x55 mm	M10x1,25x60
8	Mounting bolt 2	-	-
9	Spacer 1	t = 20 mm, d = 10 mm	t = 20 mm, d = 10 mm
10	Spacer 2	-	-
11	Nut	-	-
12	Washer	-	-

Legal note. This product is a professional accessory to be used on the race track. Neither manufacturer, nor Seller take responsibility for any damages occurred despite of using protective accessories.

Our website offers you a wide variety of motorcycle frame & body at affordable prices.