

RS188 INSTRUCTIONS

TO BE INSTALLED BY A CERTIFIED MECHANIC ONLY | FOR RACE USE ONLY

BRAKE SIDE EXPLODED VIEW

FOR: BMW S1000RR 2010



INDEX

-  Lubricate
-  Red Thread Lock
-  DO NOT Overtighten
-  Use Factory Piece

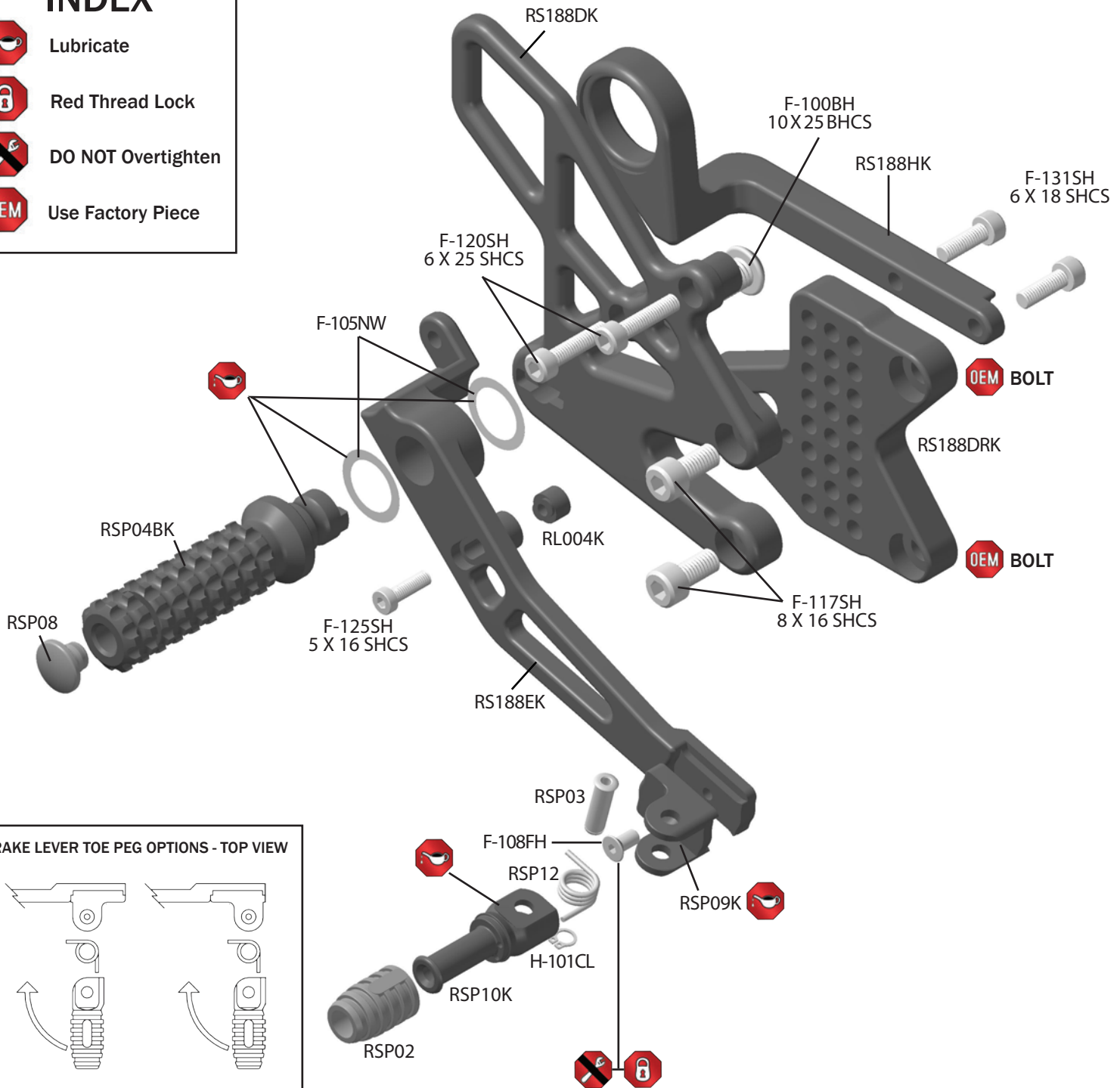

BRAKE LEVER TOE PEG OPTIONS - TOP VIEW

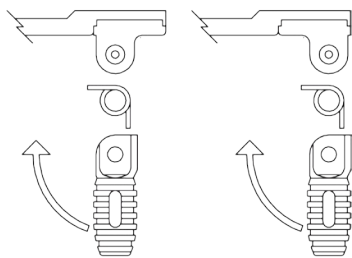

TOE PEG MUST FOLD TOWARDS FOOT PEG



BRAKE LIGHT INFO:

These rearsets do not use: OEM rear brake light switch, spring & lever return spring. In race form these rear sets no longer activate rear brake light from rear brake lever. Street use requires rear brake light to be activated by rear & front brake levers.

RS188 INSTRUCTIONS

TO BE INSTALLED BY A CERTIFIED MECHANIC ONLY | FOR RACE USE ONLY

SHIFT SIDE EXPLODED VIEW

FOR: BMW S1000RR 2010



SEE ATTACHED INSTRUCTIONS

INDEX

-  Lubricate
-  Red Thread Lock
-  DO NOT Overtighten
-  Use Factory Piece

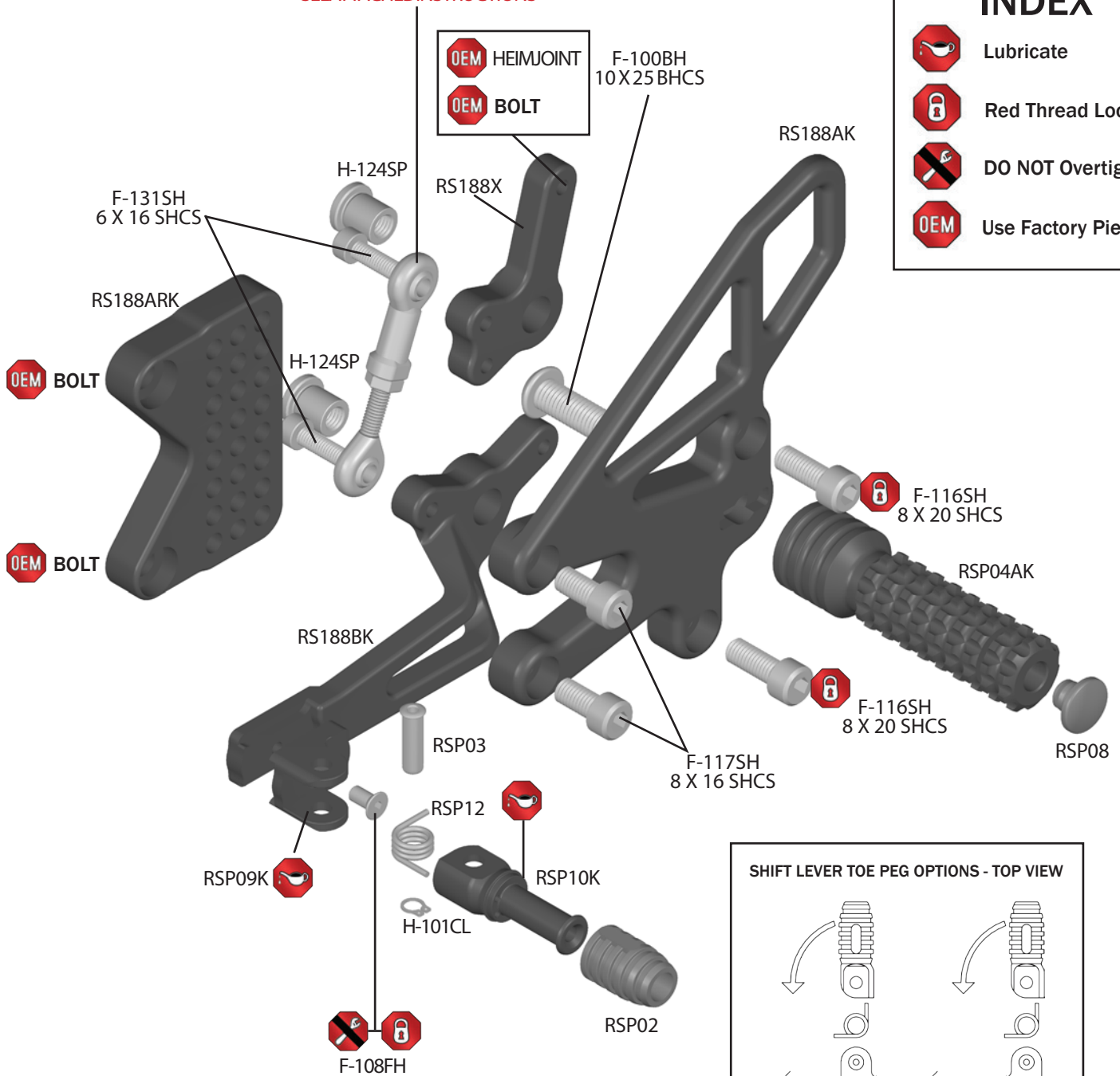

SHIFT LEVER TOE PEG OPTIONS - TOP VIEW

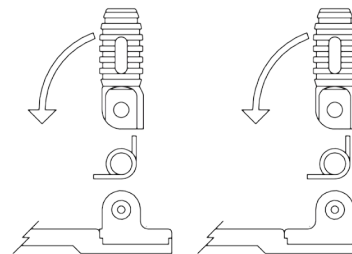

TOE PEG MUST FOLD TOWARDS FOOT PEG



RS188 SHIFT OPTIONS

TO BE INSTALLED BY A CERTIFIED MECHANIC ONLY | FOR RACE USE ONLY

FOR: BMW S1000RR 2010



STANDARD SHIFT

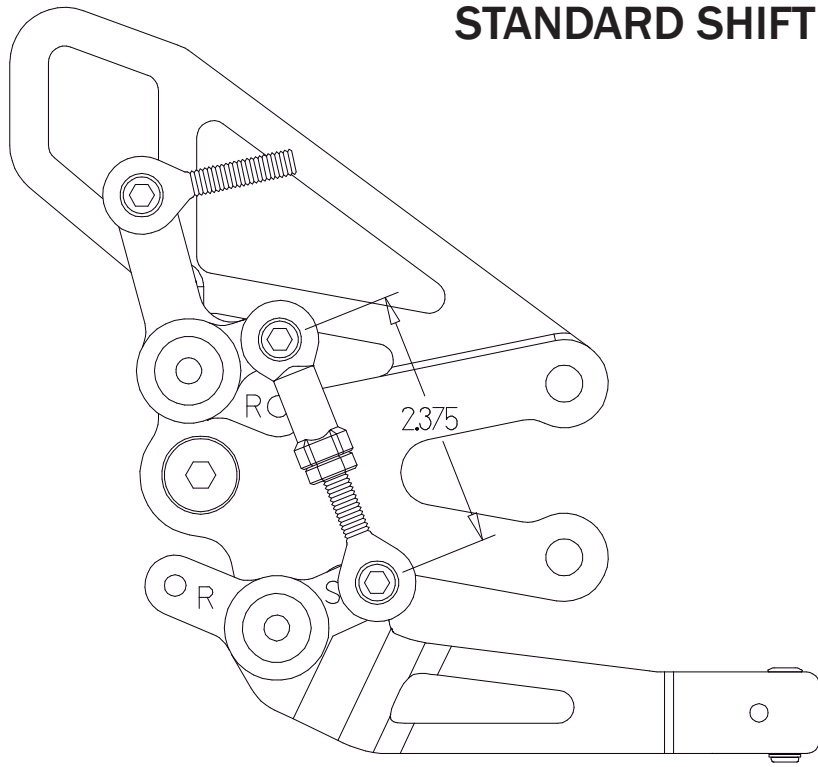

REVERSE SHIFT

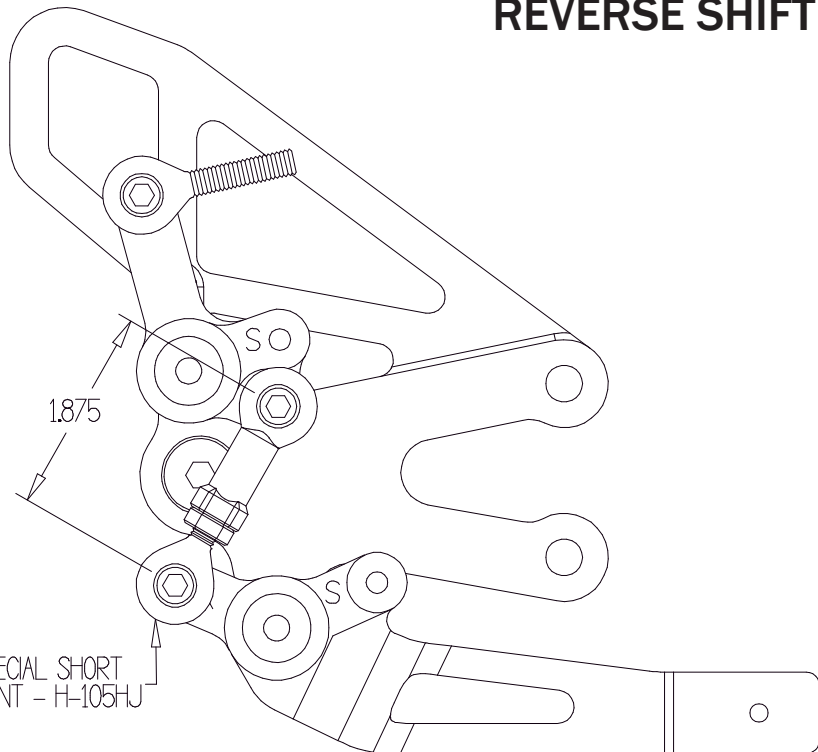

RS188 SHIFT ASSIST

TO BE INSTALLED BY A CERTIFIED MECHANIC ONLY | FOR RACE USE ONLY

FOR: BMW S1000RR 2010



To ensure the correct operation of the shift assist system please install the Vortex Shift Rod (RS188C1 Or RS188C2) as shown in the diagram. Take great care to ensure that you have the system adjusted as shown to start. Once this is set please use the heim joints on both ends of the shift rod / shift assist assembly to adjust the length for pedal position.

