

Congratulations, you have purchased the finest exhaust system available for your motorcycle. Your Vance & Hines exhaust is designed and crafted for performance, quality, and style.

FOR CLOSED COURSE COMPETITION USE ONLY. NOT INTENDED FOR STREET USE.

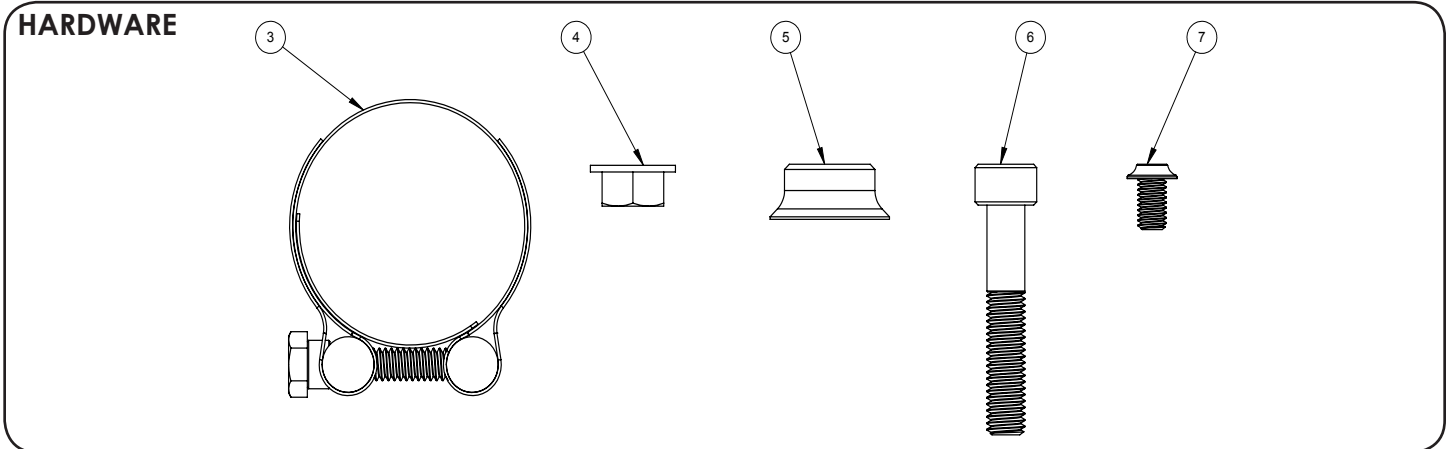
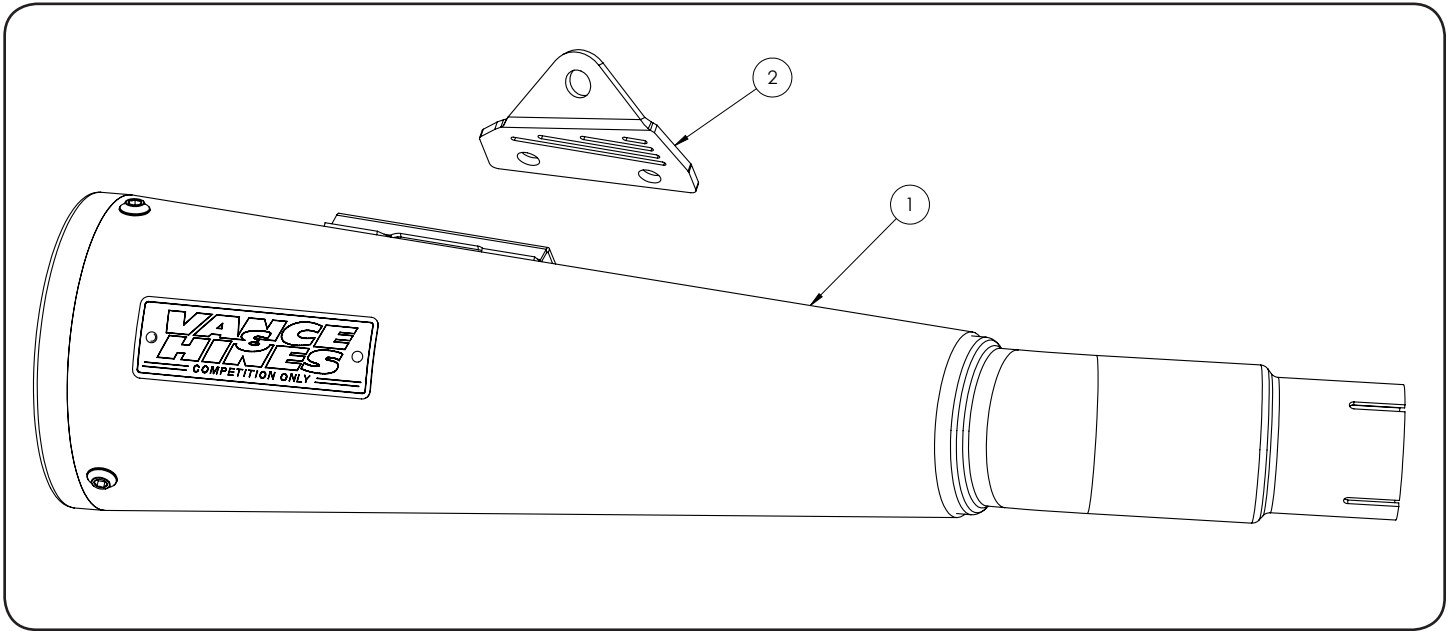

PARTS LIST

ITEM NO.	PART NO.	DESCRIPTION	QTY.
1	H635RP	HON REBEL MUFFLER W/BADGE	1
2	1112-P	MOUNT BRACKET	1
3	A328HW-B	BLK 1.81-1.99IN BARREL BAND CL	1
4	A852HW	M8 X 1.25MM SER FLNG NUT BLK	1
5	A746ST-P	FRONT SPACER BLACK	1
6	A913HW	M8 X 1.25 - 45MM SHCS ZINC	1
7	A544HW	SCREW M6X1X10MM BHCS	2

TOOLS REQUIRED



12mm combination wrench



4mm Allen wrench



6mm Allen wrench

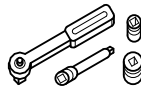

12mm socket



10mm socket

3/8" Drive Ratchet

STOCK SYSTEM REMOVAL

1. Loosen the clamp at the front of the muffler.
2. Remove the bolt that attaches the muffler to the stock mounting bracket.
3. Remove the muffler assembly from the vehicle and remove the stock gasket from the head pipe.

VANCE & HINES SYSTEM INSTALLATION

1. Install supplied M8x1.25x45mm SHCS and spacer in stock muffler mounting bracket. (Fig. 1)
2. Loosely install 1112-P bracket to muffler using two M6x1x10mm BHCS.
3. Slide provided barrel clamp over new V&H muffler, slip muffler onto stock mid-pipe. (Leave clamp loose). Make sure that barrel clamp bolt is accessible from bottom.
4. Line up muffler bracket to the inside of the muffler mounting bracket and install supplied M8x1.25 flange nut finger tight. (Fig. 1)
5. Tighten M8 muffler bracket mounting bolt to nut.
6. Tighten M6 muffler bolts.
7. Align muffler and rotate barrel clamp to be as out of sight as possible, align with leading edge of muffler and tighten.
8. Be sure all hardware is tight. Before starting the motorcycle, completely clean tail pipes and mufflers with warm soapy water and a clean soft cloth that will not leave residue. Dry with a clean towel. NOTE: Any residue, oil, or fingerprints will stain the finish when the exhaust system heats up. Do NOT use anything abrasive to clean black mufflers as it may remove the finish.

EXHAUST CARE (BLACK)

1. When installing a new set of black pipes, make sure your hands are clean and free from oil. After installation, thoroughly clean pipes with warm soapy water and a soft cloth. Dry with a clean towel remove any residue before starting the motorcycle. Do NOT use anything abrasive to clean pipes.
2. Avoid long periods of idling as this can cause discoloration.
3. Intake leaks can cause the engine to run lean and overheat, this could lead to discoloration.
4. Make sure there are no exhaust leaks at the junction of the exhaust pipes and the cylinder head. We recommend replacing gaskets if they are worn.

FIGURE 1

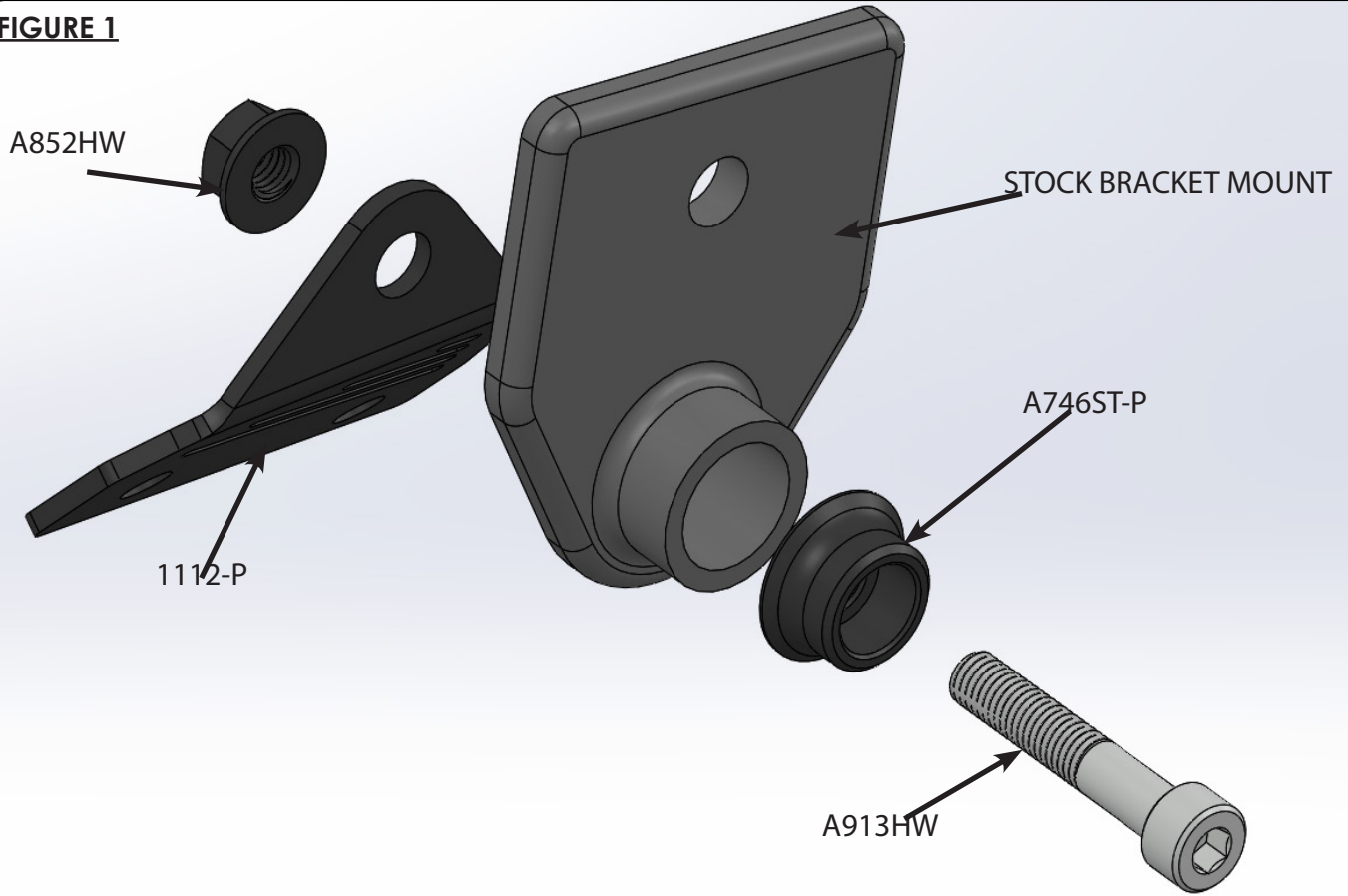

FIGURE 2



[View other motorcycle exhaust made by Vance & Hines on our website.](#)