

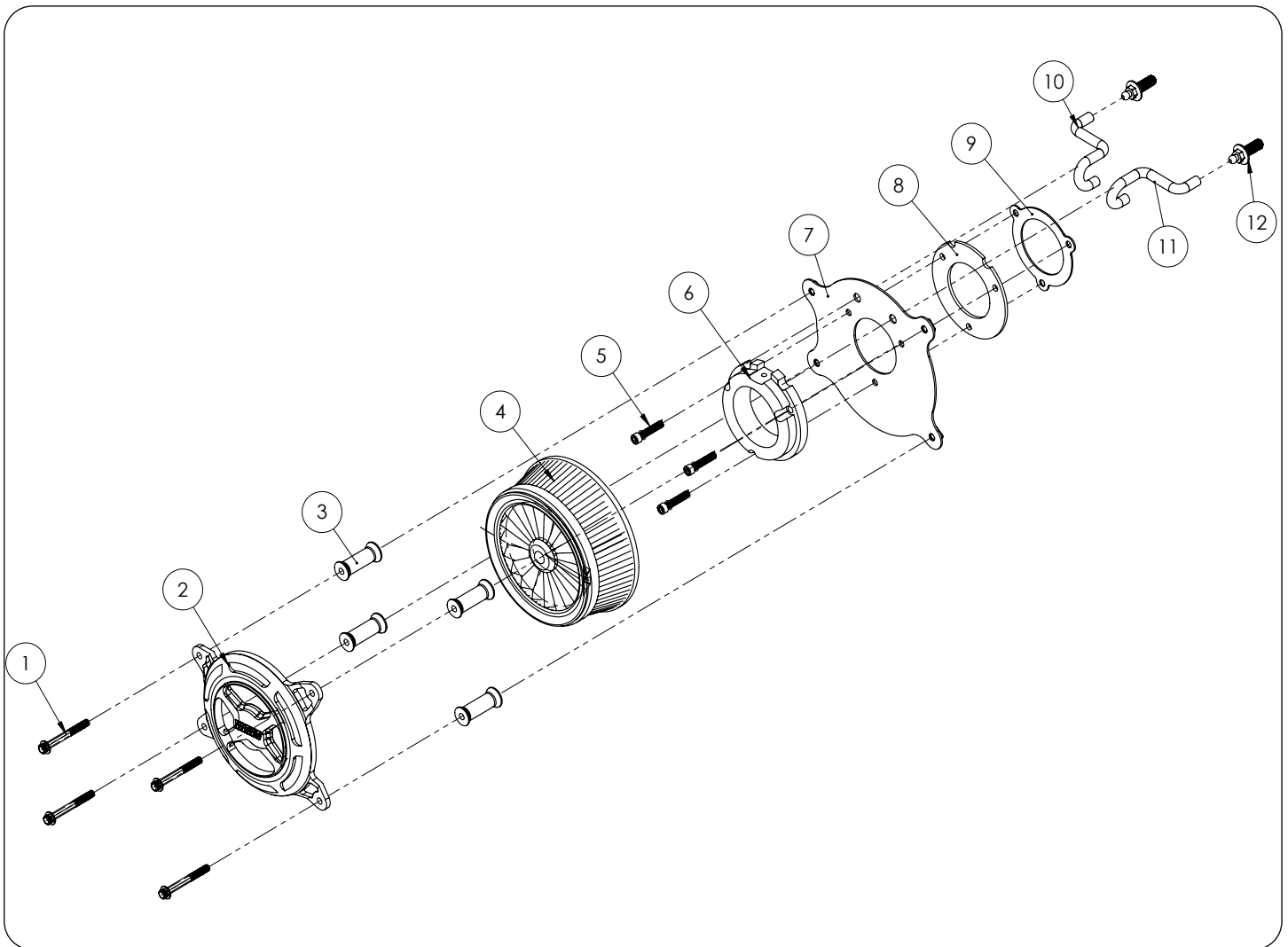

INSTALLATION INSTRUCTIONS: HARLEY-DAVIDSON 08-16 TOURING VO2 X AIR INTAKE PART# 42043 / 72043 / 42063

Congratulations, you have purchased the finest air intake available for your motorcycle. Your Vance & Hines air intake is designed and crafted for performance, quality and style.

Exempt from emissions tampering regulations under CARB EO# D-632-4 for 2008-2016 Harley-Davidson Touring and 2016-2017 Harley-Davidson Softail models



PARTS LIST

NO.	Description	Qty.		
1	12 Pt Flange Head Cap Screw	4	8	Backing Plate Stiffener
2	X Air Filter Cover	1	9	Throttle Body Gasket
3	Air Filter Standoff	4	10	Rear Breather Hose
4	Air Filter	1	11	Front Breather Hose
5	1/4-20 x 1.25 SHCS	3	12	3/8-16 UNC-2A Breather Bolt
6	Aluminum Venturi	1	13	CARB Decal D-632-4(not pictured)
7	Backing Plate	1		

TOOLS REQUIRED

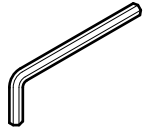

T27 Torx Wrench

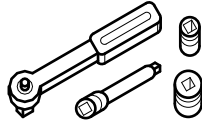

**1/4" or 3/8" Drive Ratchet
7/16" Hex Socket
5/16" Allen Socket
5/16" 12 Point Socket**

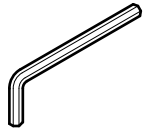

Allen Wrenches: 3/16"

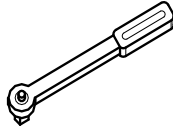

**Inch-Pound Torque
Wrench**

Loctite 243 (blue)

OEM SYSTEM REMOVAL

1. Take off the OE air filter cover by removing the 5/16" x 1/2" OE button head cap screw in the center. On some models the cap screw may be covered by a vanity cover. Carefully pull this cover off that is held on by velcrow.
2. This will expose the filter element, which is then removed by taking out the three Torx head cap screws.
3. Remove the breather hoses from the cylinder head breather bolts by gently pulling on them.
4. Now remove the backing plate and gasket by unbolting the cylinder head breather bolts. Be sure that the surface is clean and dry.

V&H AIR INTAKE INSTALLATION

1. For a clear understanding of this installation, it is best to refer to the exploded view diagram while reading these instructions.
2. When installing or servicing the air cleaner, apply Loctite 243 (blue) to the threads of all the fasteners.
3. Install the two cylinder head breather bolts **(12)**. **NOTE:** Tighten the cylinder head breather bolts to 120-144 in-lbs (13.6-16.3 Nm).
4. Install the rear and front breather hoses **(10)** & **(11)** through the top two holes in the filter backing plate **(7)**, aligned as shown.
5. Using the three 1/4"-20 x 1-1/4" socket head cap screws **(5)** sandwich the venturi **(6)**, the filter backing plate w/ breather hoses **(7)**, backing plate stiffener **(8)**, the gasket **(9)**, and install onto the throttle body. Make sure the inside edges of all of these parts are aligned before tightening to 55-60 in- lbs (6.2-6.8 Nm).
6. Install the air filter cover **(2)** onto the air filter **(4)** with the 12 point head cap screws **(1)** and air filter standoffs **(3)**. **NOTE:** Make sure the bigger end of the air filter standoffs **(3)** are closest to the bike. Also make sure to orient the air filter so that the metal fin is hidden behind the Vance & Hines logo on the air filter cover.
8. Place provided CARB EO Decal (D-632-4) in a visible location on the motorcycle's chassis near the air intake.
7. After 100 miles check to be sure that all bolts are still tight. Periodically ensure that these screws remain tight.