

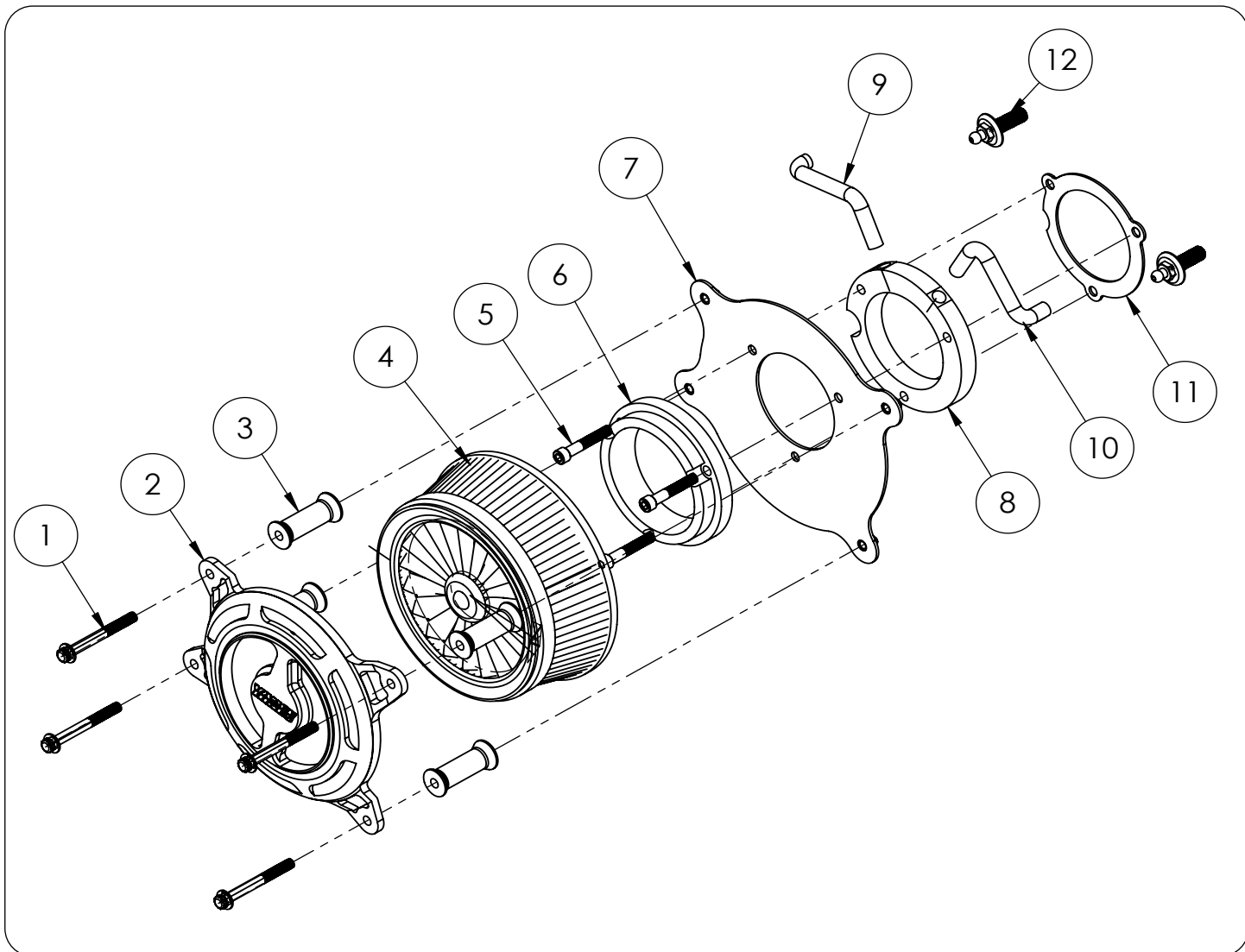

# INSTALLATION INSTRUCTIONS: HARLEY-DAVIDSON 18-20 SOFTAIL VO2 BLADE AIR INTAKE PART# 40097 / 70097 / 42057

Congratulations, you have purchased the finest air intake available for your motorcycle. Your Vance & Hines air intake is designed and crafted for performance, quality and style.

Exempt from emissions tampering regulations under CARB EO# D-632-4 for 2018-2021 Harley-Davidson Softtail models.



## PARTS LIST

NO.	Description	Qty.			
1	12 Pt Flange Head Cap Screw	4	8	Throttle Body Spacer	1
2	Blade Air Filter Cover	1	9	Rear Breather Hose	1
3	Air Filter Standoff	4	10	Front Breather Hose	1
4	Air Filter	1	11	Throttle Body Gasket	1
5	1/4-20 x 1.50 SHCS	3	12	3/8-16 UNC-2A Breather Bolt	2
6	Aluminum Venturi	1	13	Carb Decal D-632-4(not pictured)	1
7	Backing Plate	1			

## TOOLS REQUIRED

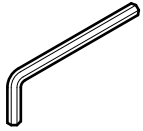

**T27 Torx Wrench**

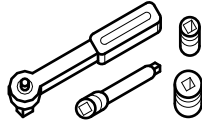

**1/4" or 3/8" Drive Ratchet  
7/16" Hex Socket  
5/16" Allen Socket  
5/16" 12 point socket**

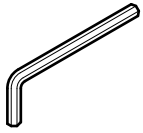

**Allen Wrenches: 3/16"**

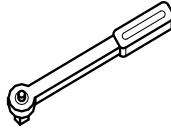

**Inch-Pound Torque  
Wrench**

**Loctite 243 (blue)**

## OEM SYSTEM REMOVAL

1. Take off the OE air filter cover. On some models the cap screw may be covered by a vanity cover. Carefully pull this cover off that is held on by velcrow.
2. This will expose the filter element, which is then removed by taking out the three Torx head cap screws.
3. Remove the breather hoses from the cylinder head breather bolts by gently pulling on them.
4. Now remove the backing plate and gasket by unbolting the cylinder head breather bolts. Be sure that the surface is clean and dry. **NOTE:** If you own a 114 "S" model Softail, please note that separate purchase of the induction module bracket from Harley Davidson, P/N: 16400049 is necessary and must be installed prior to installing this air intake system.

## V&H AIR INTAKE INSTALLATION

1. For a clear understanding of this installation, it is best to refer to the exploded view diagram while reading these instructions.
2. When installing or servicing the air cleaner, apply Loctite 243 (blue) to the threads of all the fasteners.
3. Install the two cylinder head breather bolts **(12)**. **NOTE:** Tighten the cylinder head breather bolts to 120-144 in-lbs (13.6-16.3 Nm).
4. Install the rear and front breather hoses **(9)** & **(10)** through the top two holes in the filter backing plate **(7)**, aligned as shown.
5. Using the three 1/4"-20 x 1-1/4" socket head cap screws **(5)** sandwich the venturi **(6)**, the filter backing plate w/ breather hoses **(7)**, backing plate stiffener **(8)**, the gasket **(11)**, and install onto the throttle body. Make sure the inside edges of all of these parts are aligned before tightening to 55-60 in- lbs (6.2-6.8 Nm).
6. Install the air filter cover **(2)** onto the air filter **(4)** with the 12 point head cap screws **(1)** and air filter standoffs **(3)**. **NOTE:** Make sure the bigger end of the air filter standoffs **(3)** are closest to the bike. Also make sure to orient the air filter so that the metal fin is hidden behind the Vance & Hines logo on the air filter cover.
7. Place provided CARB EO Decal (D-632-4) in a visible location on the motorcycle's chassis near the air intake.
8. After 100 miles check to be sure that all bolts are still tight. Periodically ensure that these screws remain tight.