

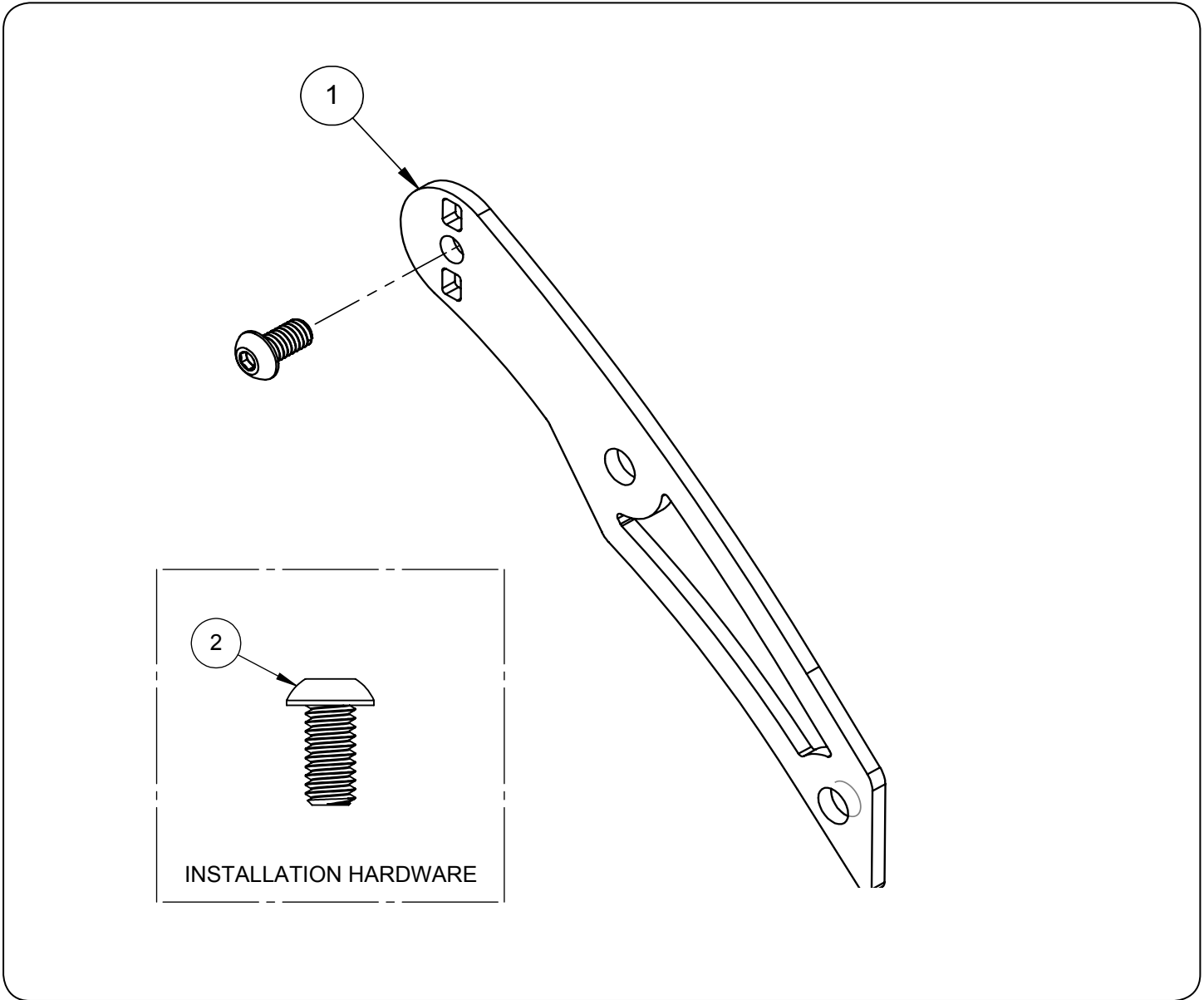

INSTALLATION INSTRUCTIONS:  
HARLEY-DAVIDSON SOFTAIL  
SADDLEBAG MOUNT BRACKET  
PART# 21946



**PARTS LIST**

NO.	Description	Qty.
1	SADDLEBAG MOUNT BRACKET	1
2	5/16-18 X 5/8 IN SS BUTTON HEAD	1

## TOOLS REQUIRED

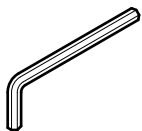

**Allen Wrenches: 3/16",  
5/16"**

## OEM SYSTEM REMOVAL / V&H AIR INTAKE INSTALLATION

**NOTE:** Exhaust must be off the bike to access saddlebag mounting fasteners.

1. Take off the OEM exhaust mounting bar. Save hardware for reuse.
2. Remove saddlebag rubber grommet and install onto the new bracket using fastener A435HW.
3. Install the new saddlebag mounting bracket using stock hardware. (see **FIGURE 1**)
4. After 100 miles check to be sure that all bolts are still tight. Periodically ensure that these screws remain tight.

**FIGURE 1**

