

Congratulations, you have purchased the finest exhaust system available for your motorcycle. Your Vance & Hines exhaust is designed and crafted for performance, quality, and style.

Fits 1995-2016 Harley-Davidson Touring Models*

FOR CLOSED COURSE COMPETITION USE ONLY. NOT INTENDED FOR STREET USE.

*Qualified Manufacturer Declared Replacement Part for 2009-2016 Harley Davidson Touring Models.

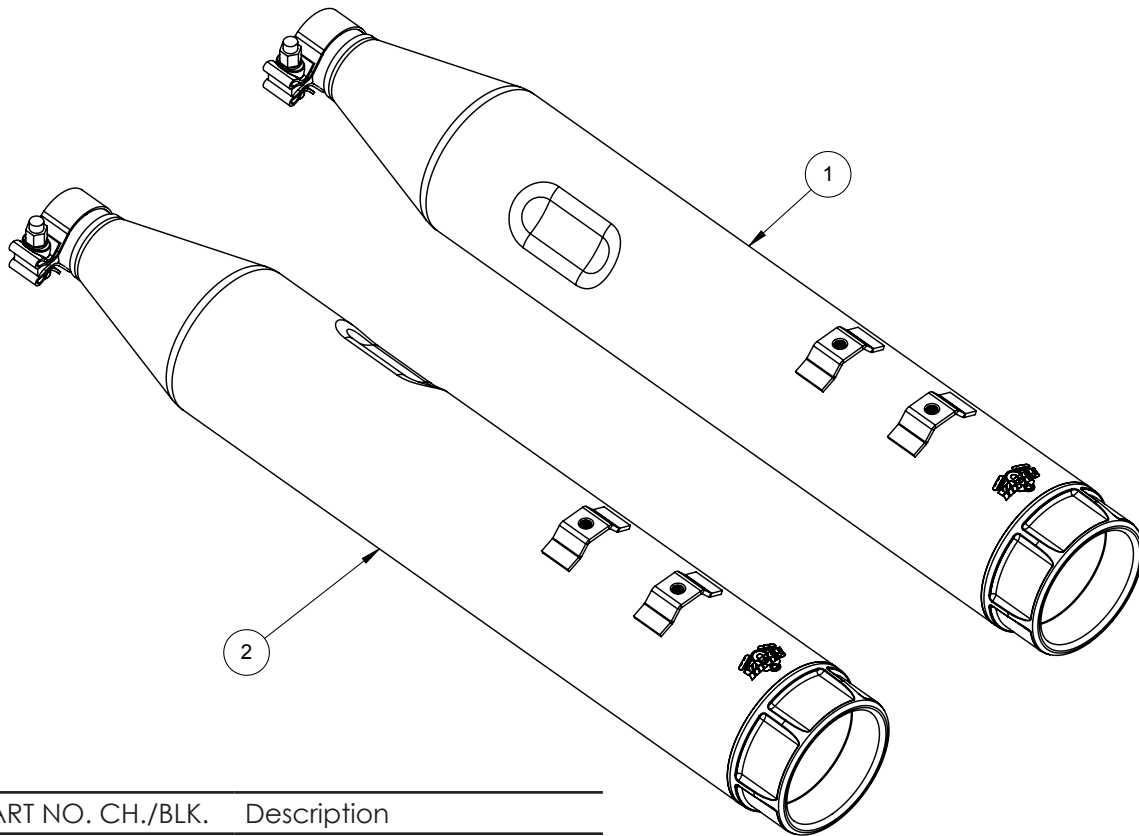

NO.	PART NO.	CH./BLK.	Description	
1	D920RC / D930RP		RH Muffler	1
2	D921RC / D931RP		LH Muffler	1
3	A335HW		1.88" Band Clamp	2

HARDWARE

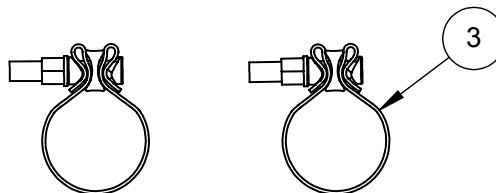

TOOLS REQUIRED

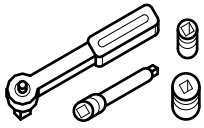

TORQUE WRENCH
3/8" DRIVE RATCHET WITH 3" EXTENSION
1/2" & 9/16" SOCKET

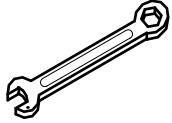

1/2", 9/16" WRENCH

STOCK EXHAUST SYSTEM REMOVAL

1. Remove both saddlebags and set them aside.
2. Loosen the bolt from the pinch clamp on the front end of each muffler.
3. Working with one muffler at a time, support the muffler (assistance may be required) while removing the 5/16" bolts from the saddlebag support and slide muffler off of the head pipe.
4. Repeat the process for the opposite muffler. **NOTE:** It may be necessary to use a penetrating lubricant to loosen the muffler from the head pipe.

VANCE & HINES EXHAUST INSTALLATION

1. Install the Torca clamps over the front of each muffler inlet so that the bolt is to the inside and the nut is facing down.
2. Slide right side muffler on. **Note:** Dent will be on the inside.
3. Install the stock bolts and washers through the mounting bracket to the muffler. Finger tighten only.
4. Repeat installation procedure for the opposite muffler.
5. Align mufflers bodies then torque the band clamps to 40-44 ft. lbs. Torque the bolts to 18 ft. lbs.
6. Replace the saddlebags.
7. After installation and before starting motorcycle, completely clean pipes and mufflers with soapy water and a clean, soft cloth that will not leave residue. **NOTE:** Any residue, oil, or fingerprints will stain the finish when the metal heats up.
8. Be sure to tighten all hardware before starting your motorcycle.
9. **IMPORTANT:** AFTER TEST RIDE LET PIPES COOL DOWN AND RE-TORQUE MUFFLER BAND CLAMP.

EXHAUST CARE (CHROME)

1. When installing a new set of chrome pipes, make sure your hands are clean and free of oil. After installation, thoroughly clean pipes with a soft cloth and soapy water that will leave no residue (chrome wax, polish, glass cleaner, alcohol, ammonia, etc.) before starting the motorcycle.
2. Avoid long periods of idling as this can cause discoloration.
3. Intake leaks can cause the engine to run lean and overheat, this could lead to discoloration.
4. Make sure there are no exhaust leaks at the junction of the exhaust pipes and the cylinder head. We recommend replacing gaskets if they are worn.

EXHAUST CARE (BLACK)

1. When installing a new set of black pipes, make sure your hands are clean and free of oil. After installation, thoroughly clean pipes with warm soapy water and a soft cloth. Dry with a clean towel to remove any residue before starting the motorcycle. Do NOT use anything abrasive to clean pipes.
2. Avoid long periods of idling as this can cause discoloration.
3. Intake leaks can cause the engine to run lean and overheat, this could lead to discoloration.
4. Make sure there are no exhaust leaks at the junction of the exhaust pipes and cylinder head. We recommend replacing gaskets if they are worn.