

MORE POWER : LESS NOISE



Congratulations, you have purchased the finest exhaust system for your motorcycle on the market. Your Vance & Hines exhaust system is designed and crafted for maximum performance, a perfect fit, a great sound and unbeatable style.

Attention installer (if other than owner), please forward this instruction sheet to the owner of this product. These instructions contain valuable information to the end user.

**TOOLS
REQUIRED**

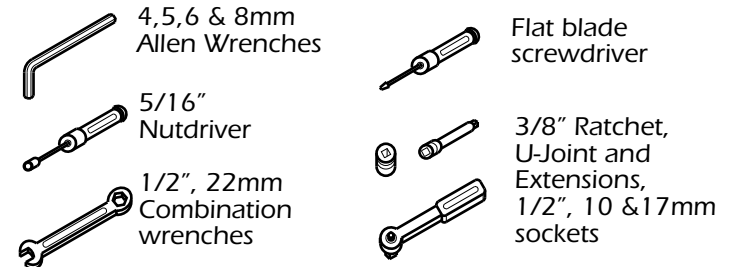

READ ALL INSTRUCTIONS BEFORE BEGINNING INSTALLATION

**STOCK EXHAUST
SYSTEM REMOVAL**

1. Cover the frame tube in front of the exhaust with duct tape or any suitable material to protect frame from scratching during exhaust removal.
2. Loosen and remove the two bolts on the rear brake pedal assembly with a 12mm socket and carefully lower it out of the way.
3. Using a 6mm Allen wrench, loosen both clamps that hold the muffler body to the collector.
4. Remove the three allen cap screws holding bracket/muffler bodies to frame with an 8mm allen, and remove/slide muffler body off.
5. Remove plastic side cover to access O2 sensor plug and unplug sensor at connector. Disconnect black cable tie and put aside for use later (Figure 1). Note O2 cable routing for re-installation.
6. Using the 5mm Allen wrench, remove the lower bolts securing the radiator to the frame and carefully lower radiator to provide better access to the front exhaust port nuts. NOTE: On California models use a 4mm Allen wrench to remove the Evap canister on the left side to gain access to the 5mm bolts.
7. Remove the four flange nuts holding the exhaust headers to the cylinder heads. Save these for re-use. NOTE: It may be necessary to loosen the heat shield clamps to access the nuts on the front cylinder. Carefully remove the header from the motorcycle (may require assistance).
8. Using a 22mm wrench, carefully remove the O2 sensor from the exhaust pipe and put aside for reuse later.
9. Check the stock exhaust gaskets to be sure they are in good condition. If you have any doubts as to their condition, replace them.

FIGURE 1



FIGURE 2

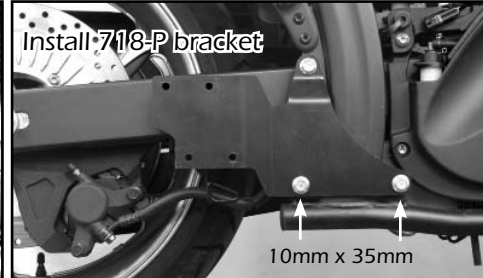

FIGURE 3

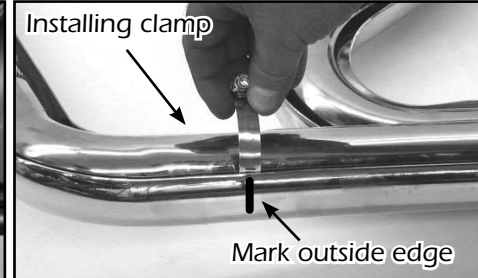

FIGURE 4

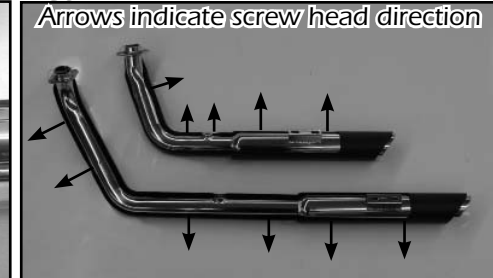

FIGURE 5



FIGURE 6

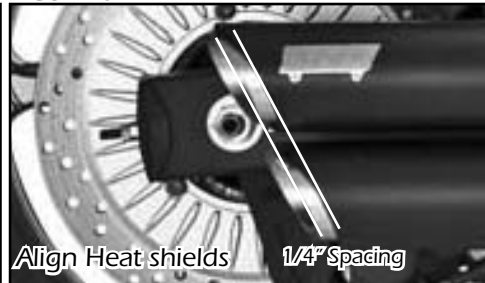
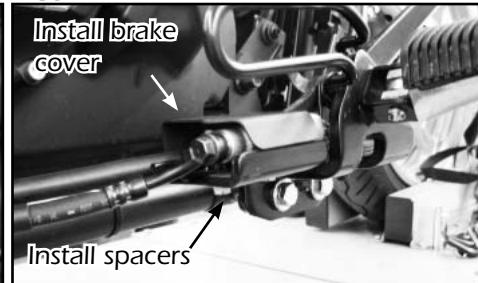

FIGURE 7



VANCE & HINES EXHAUST SYSTEM INSTALLATION

1. Install mounting bracket 718-P to frame by using two 10mm x 35mm and one 10mm x 20mm hex head bolts (supplied) (Figure 2).
2. Remove head pipe assemblies and head pipe heat shields from protective packaging. Place each heat shield on a non-abrasive surface such as a blanket or carpet. Using a pencil, mark outside edge of each heat shield to show location of mounting clips that hose clamps will loop through (Figure 3). NOTE: Do not use a marking pen will as it will stain the finish.
3. Apply a small amount of anti-seize compound to the threads of the O2 sensor and install it into the front head pipe. NOTE: Be careful not to get anti-seize on O2 sensor tip, it may affect sensor function.
4. Lay head pipes into their respective heat shields.
5. Install #20 hose clamps by feeding tail end of clamps into heat shield clips (Figure 4). Take note of clamp screw head direction (Figure 4). Screw head must be accessible when system is installed on motorcycle for adjustment purposes. NOTE: Position clamps so they will not scratch the chrome covers on the motorcycle.
6. Using stock flange nuts, carefully install head pipes into exhaust ports, NOTE: Use caution not to scratch the black finish. Do not tighten at this time.
7. Slide the two nut plates (supplied) into the brackets that are welded to the back side of the mufflers (Figure 5). Loosely install four 5/16" x 5/8" flange head bolts (supplied).
8. Tighten the exhaust port flange nuts, then 5/16" x 5/8" flange head bolts.
9. Using #36 hose clamps (supplied), and following the same procedures as steps 2 & 5, carefully install the muffler body heat shields onto muffler bodies.
10. Align muffler body heat shields with the end of the muffler bodies, then slide them towards the front of the motorcycle leaving a 1/4" gap exposing the chrome muffler bodies (Figure 6).
11. Tighten all hose clamps securing heat shields.
12. Insert the rear O2 sensor plug into harness and tuck harness into same route position. Re-install plastic cover removed to gain access to the O2 plug.
13. Re-install the rear brake pedal assembly with two supplied spacers and two 10mm x 120 mm hex head bolts (supplied) . Install the spacers (one per bolt) between the rear brake pedal assembly and frame for proper clearance (Figure 7).
14. Remove the two flange head bolts holding the brake master cylinder to the brake pedal assembly, Holding the brake master cylinder in place carefully slip the brake master cylinder heat shield (marked A115HP) over the master cylinder. The brake master cylinder heat shield should be over the top of the brake master cylinder and under the brake pedal assembly mounting plate. Re-install the two master cylinder stock flange head bolts, passing the flange head bolts through the master cylinder heat shield, brake pedal assembly mounting plate and into the brake master cylinder securing both the heat shield and the master cylinder to the brake pedal assembly (Figure 7).
15. Check for adequate clearance between all exhaust system components and motorcycle accessories prone to heat damage.
16. Be sure to tighten all hardware before starting your motorcycle.
17. After installation and before starting motorcycle, completely clean pipes and mufflers with soap and water and a clean soft cloth that will not leave a residue. NOTE: Any residue, oil, or fingerprints will stain the finish when the metal heats up.

EXHAUST CARE - HELPFUL HINTS TO AVOID DISCOLORATION OF EXHAUST SYSTEM

1. When installing a new set of pipes, make sure your hands are clean and free of oil. After installation, thoroughly clean pipes with warm soapy water and a soft cloth. Dry with clean towel to remove any residue before starting the motorcycle. Do NOT use anything abrasive to clean pipes.
2. Avoid long periods of idling as this can cause discoloration.
3. Intake leaks can cause the engine to run lean and overheat, this could lead to discoloration.
4. Make sure there are no exhaust leaks at the junction of the exhaust pipes and cylinder head. We recommend replacing gaskets if they are worn.

VANCE & HINES OPTIONAL ACCESSORIES

FUELPAK



FUEL MANAGEMENT:
Take the guess work out of fuel injection with Fuelpak Fuel Management.
Fuelpak is intended for racing or off-highway use only, and is not legal for sale or use in California on pollution-controlled vehicles.

PLEASE NOTE: Every effort is made for Vance & Hines Exhaust Systems to provide improved cornering clearance. However, due to design and space limitations on some motorcycle models, ground and cornering clearance may not be improved and in some cases may be reduced. Be sure to follow proper installation instructions.

PACKING LIST

MORE POWER : LESS NOISE

ALL PARTS SHOWN ARE ACTUAL SIZE

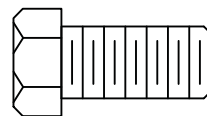
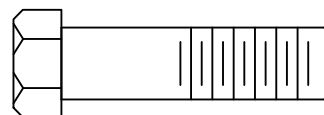
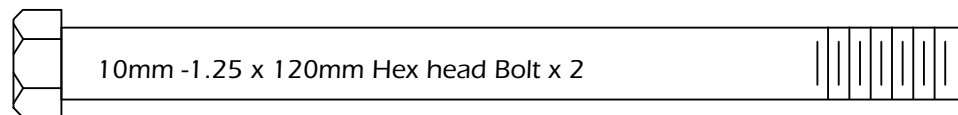
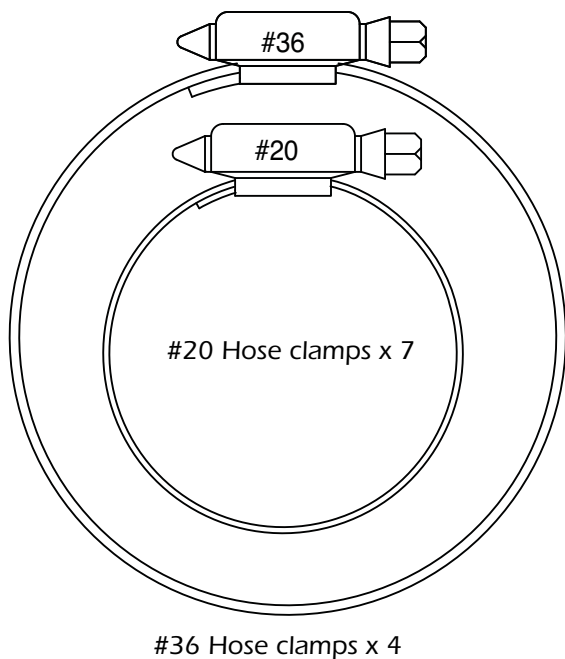

5/16" x 5/8" Flange head bolts x 4

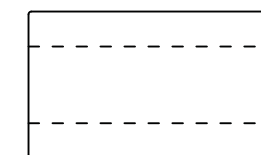
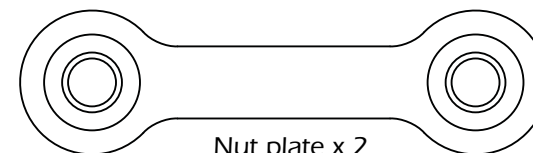
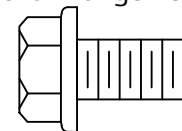

PARTS NOT SHOWN:

718-P	Bracket	x1
A115HP	Brake Master Cyl Cover	x1
Y368FC	Front Cyl Header	x1
Y369FC	Rear Cyl Header	x1
Y368HP	Front Cyl heat shield	x1
Y369HP	Rear Cyl heat shield	x1
S397HP	Front Cyl Muffler HS	x1
S398HP	Rear Cyl Muffler HS	x1

WARRANTY

Vance & Hines exhaust systems are warranted against defects in material and workmanship for a period of 90 days from the date of purchase from an authorized dealer. This warranty does not cover discoloration of chrome finishes. This warranty is limited to the repair or replacement of a product proven to be defective from normal use. Vance & Hines exhaust systems are designed to fit and operate on OEM motor and chassis. This warranty does not cover any product subject to abuse, misuse, improper installation or modification.

FUEL MANAGEMENT

GET THE MOST OUT OF YOUR RIDING EXPERIENCE...

AN AFTERMARKET EXHAUST SYSTEM IS ONLY YOUR FIRST STEP, NOW YOU NEED FUEL MANAGEMENT.

NOW YOU NEED FUELPAK.

Your fuel injected motorcycle is equipped with an ECU (electronic control unit) that's programmed to deliver fuel to the motor based on an air/fuel ratio for a stock air filter and stock exhaust system. When you install a performance exhaust system, your airflow changes, so you need a fuel management system that adjusts your air/fuel ratio to match the changes. That fuel management system is Fuelpak. Fuelpak adds and takes away fuel, allowing for a more precise range of refinement in your air/fuel ratio. Get the perfect fuel management combination with your Vance & Hines exhaust system, get Fuelpak.

NOTICE: Fuelpak is intended for racing or off-highway use only, and is not legal for sale or use in California on pollution-controlled vehicles.



MORE POWER : LESS NOISE

Vance & Hines puts everything within reach.

Discover other exhaust parts on our website.