

Congratulations, you have purchased the finest exhaust system available for your motorcycle. Your Vance & Hines exhaust is designed and crafted for performance, quality, and style.

Fits 2017 Harley-Davidson Touring Models\*

FOR CLOSED COURSE COMPETITION USE ONLY. NOT INTENDED FOR STREET USE.

\*Qualified Manufacturer Declared Replacement Part for 2017 Harley Davidson Touring Models.

### PARTS LIST

| ITEM NO. | PART NO. | DESCRIPTION       | QTY. |
|----------|----------|-------------------|------|
| 1        | D638RC   | RT. MUFFLER       | 1    |
| 2        | D627RC   | LT. MUFFLER       | 1    |
| 3        | A337HW   | 2-5/8" BAND CLAMP | 1    |
| 4        | A335HW   | 2" BAND CLAMP     | 1    |

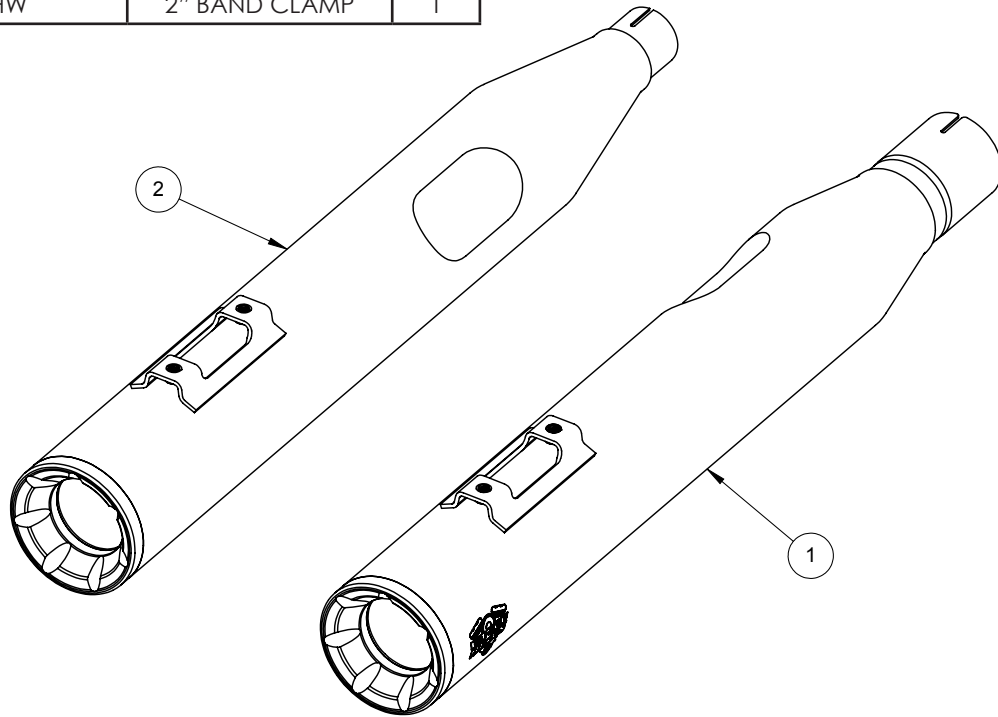

### HARDWARE

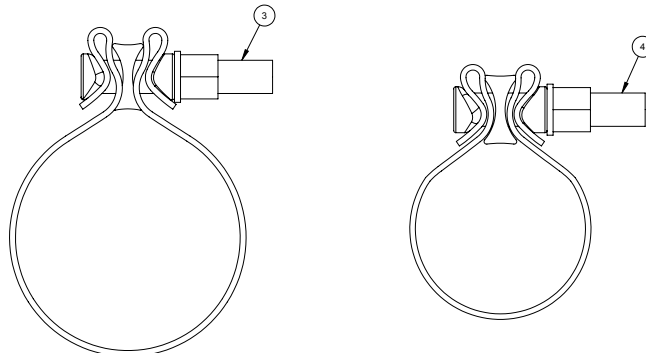

## TOOLS REQUIRED

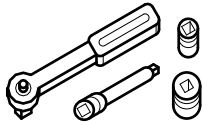

3/8" DRIVE RATCHET WITH 4" EXTENSION  
1/2", 9/16", 15mm SOCKETS

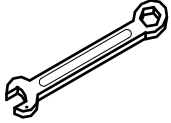

1/2", 9/16", 15mm COMBINATION  
WRENCHES

## STOCK EXHAUST SYSTEM REMOVAL

1. Remove both saddlebags and set them aside.
2. Loosen the bolt from the pinch clamp on the front end of each muffler.
3. Working with one muffler at a time, support the muffler (assistance may be required) while removing the 5/16" bolts from the saddlebag support and slide muffler off of the head pipe. Save the bolts for re-use.
4. Repeat the process for the opposite muffler. **NOTE:** It may be necessary to use a penetrating lubricant to loosen the muffler from the head pipe.

## VANCE & HINES EXHAUST INSTALLATION

1. Install the 2" band clamp over the front of the left muffler and the 2-5/8" band clamp over the right muffler so that the bolt is to the inside and the nut is facing down (Figure 1). **NOTE:** New band clamps are supplied, do not use old band clamps.
2. Install the muffler by sliding it on to the head pipe and bolting it to the saddlebag support using the stock 5/16" bolts.
3. Repeat installation procedure for opposite muffler.
4. Align mufflers and tighten hardware, beginning with the 5/16" bolts on the mounting brackets as followed by the band clamp. Tighten 5/16" bolts to factory specs, and the band clamp to 40-45 Ft./Lbs.
5. Replace the saddlebags.
6. After installation and before starting motorcycle, completely clean pipes and mufflers with soapy water and a clean, soft cloth that will not leave a residue. **NOTE:** Any residue, oil, or fingerprints will stain the finish when the metal heats up.
7. Be sure to tighten all hardware before starting your motorcycle.

**FIGURE 1**

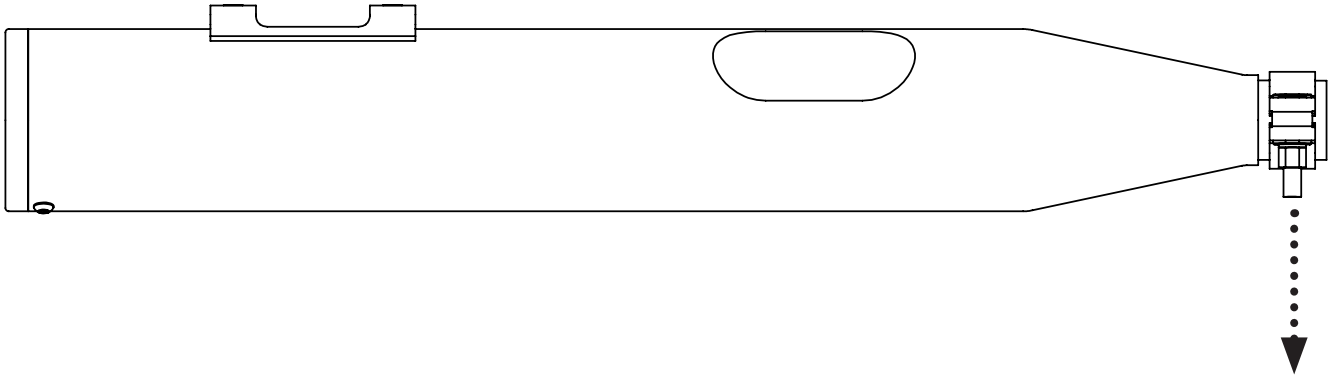

### **EXHAUST CARE**

1. When installing a new set of chrome pipes, make sure your hands are clean and free of oil. After installation, thoroughly clean pipes with a soft cloth and soapy water that will not leave residue (chrome wax / polish, glass cleaner, alcohol, ammonia, etc...) before starting the motorcycle. Dry with a clean towel to remove any residue before starting the motorcycle.
2. Avoid long periods of idling as this can cause discoloration.
3. Intake leaks can cause the engine to run lean and overheat, this could lead to discoloration.
4. Make sure there are no exhaust leaks at the junction of the exhaust pipes and the cylinder head. We recommend replacing gaskets if they are worn.

### **EXHAUST CARE (BLACK)**

1. When installing a new set of black pipes, make sure your hands are clean and free of oil. After installation, thoroughly clean pipes with warm soapy water and a soft cloth. Dry with a clean towel to remove any residue before starting the motorcycle. Do NOT use anything abrasive to clean the pipes.
2. Avoid long periods of idling as this can cause discoloration.
3. Intake leaks can cause the engine to run lean and overheat, this could lead to discoloration.
4. Make sure there are no exhaust leaks at the junction of the exhaust pipes and the cylinder head. We recommend replacing gaskets if they are worn.

Emissions Notice:

In California, in order to meet Air Resources Board emissions requirements, certain aftermarket part applications have been identified as replacements, and others have received ARB Executive Orders. All other emissions related aftermarket parts are for competition use only.

Warranty:

All Vance & Hines products are warranted against defects in material and workmanship for a period of 90 days. This warranty does not cover discoloration or rust. This warranty shall be limited to the repair or replacement of the product, which may be proven defective under normal use. Vance & Hines will not warranty any system that has been abused, misused, improperly installed or modified.

Dealers or distributors are not authorized to make dispositions binding upon Vance & Hines. Vance & Hines will not be responsible for any labor charges incurred in removing or replacing any system under warranty. A return authorization number and a copy of the original purchase invoice must accompany all returns. Parts returned without a return authorization may be refused.