



**INSTALLATION INSTRUCTIONS:  
HARLEY-DAVIDSON TOURING  
2017-2018 OVERSIZED 450 DESTROYER SLIP-ONS  
PART# 16654 / 16656 / 46654**

Congratulations, you have purchased the finest exhaust system available for your motorcycle. Your Vance & Hines exhaust is designed and crafted for performance, quality, and style.

Fits 2017-2018 Harley-Davidson Touring Models\*

FOR CLOSED COURSE COMPETITION USE ONLY. NOT INTENDED FOR STREET USE.

\*Qualified Manufacturer Declared Replacement Part for 2017-2018 Harley Davidson Touring Models.

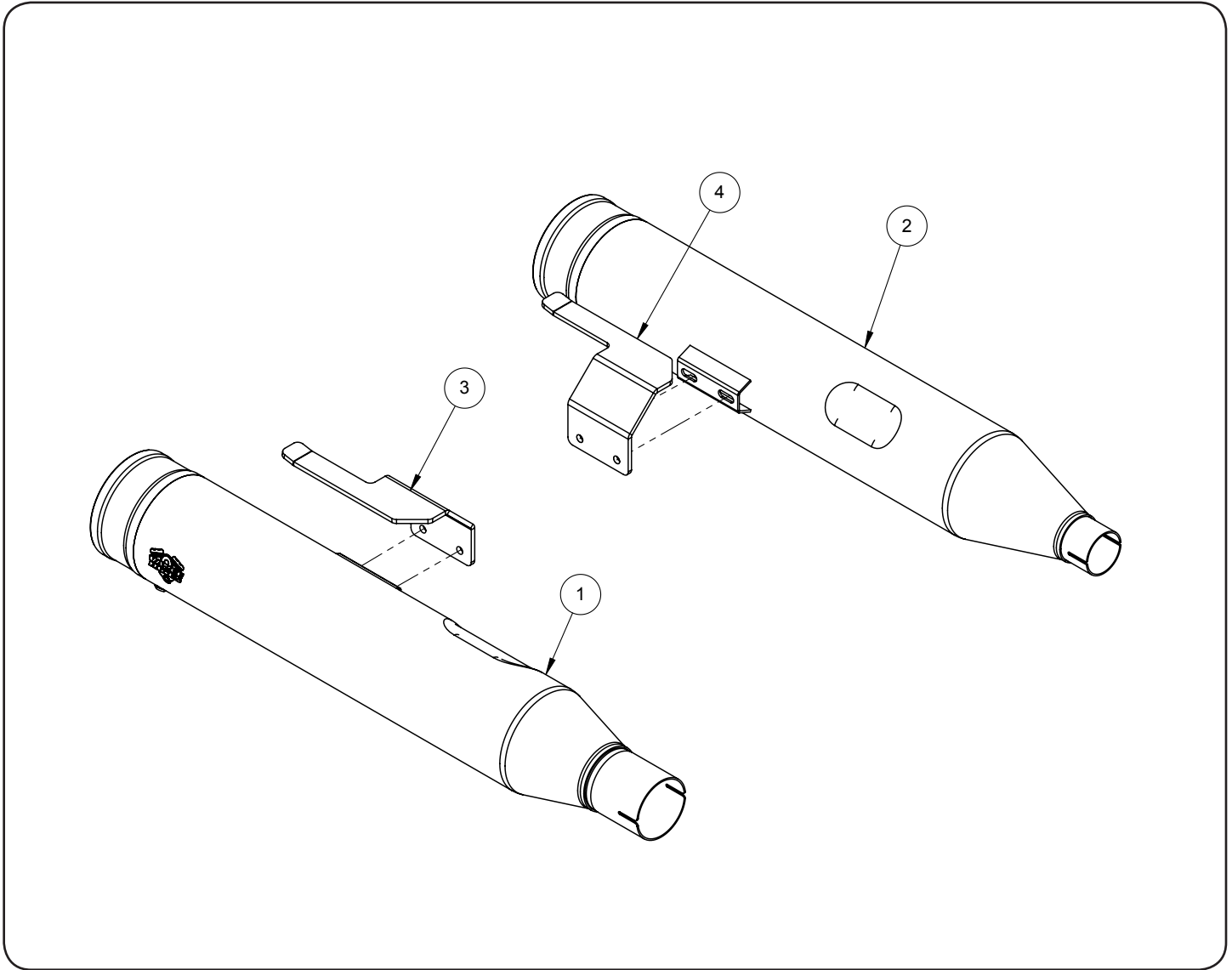

**PARTS LIST**

| NO. | PART NO.        | CH./BLK. | Description   |   |    |        |                   |   |
|-----|-----------------|----------|---------------|---|----|--------|-------------------|---|
| 1   | D612RC / D634RP |          | Right Muffler | 1 | 5. | A195HW | Nutplate          | 1 |
| 2   | D623RC / D633RP |          | Left Muffler  | 1 | 6  | A240HW | Flange Bolt       | 2 |
| 3   | 757-P           |          | Right Bracket | 1 | 7  | A335HW | 2" Band Clamp     | 1 |
| 4   | 758-P           |          | Left Bracket  | 1 | 8  | A337HW | 2.625" Band Clamp | 1 |

## HARDWARE

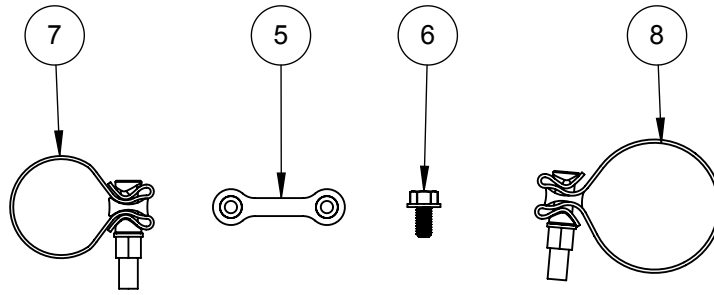

## TOOLS REQUIRED

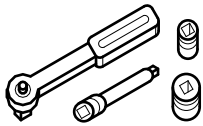

TORQUE WRENCH  
DRIVE RATCHET WITH 3" EXTENSION  
1/2" SOCKETS,  
9/16", 15mm DEEP SOCKET

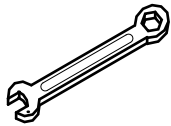

1/2", 9/16" WRENCH

## STOCK EXHAUST SYSTEM REMOVAL

1. Remove both saddlebags and set them aside.
2. Loosen the bolt from the pinch clamp on the front end of each muffler.
3. Working with one muffler at a time, support the muffler (assistance may be required) while removing the 5/16" bolts from the saddlebag support and slide muffler off of the head pipe.
4. Repeat the process for the opposite muffler. **NOTE:** It may be necessary to use a penetrating lubricant to loosen the muffler from the head pipe.
5. Leaving the grommets in place, remove the stock mounting brackets from the rubber grommets located on the saddlebag supports. **NOTE:** Inspect the grommets to verify that they are in good condition; if the grommets are damaged they will need to be replaced.

## VANCE & HINES EXHAUST INSTALLATION

1. Install the muffler brackets 757-P (item 3) on the right side and 758-P (item 4) on the left side (See **Figure 1**).
2. Install the Torca clamps over the front of each muffler inlet so that the bolt is to the inside and the nut is facing down. (See **Figure 2**).
3. Slide right side muffler on. **Note:** Dent will be on the inside.
4. Slide the nut plates inside the brackets that are welded to the backside of the muffler bodies and attach the muffler to the muffler support bracket using two 5/16 flange bolts (supplied). Finger tighten only.
5. Repeat installation procedure for the opposite muffler.
6. Align mufflers bodies then torque the band clamps to 40-44 ft. lbs. Slide the muffler support bracket as far as possible rearward before tightening the two flange bolts. Torque the bolts to 18 ft. lbs.
7. Replace the saddlebags.
8. After installation and before starting motorcycle, completely clean pipes and mufflers with soapy water and a clean, soft cloth that will not leave residue. **NOTE:** Any residue, oil, or fingerprints will stain the finish when the metal heats up.
9. Be sure to tighten all hardware before starting your motorcycle.

## EXHAUST CARE (CHROME)

1. When installing a new set of chrome pipes, make sure your hands are clean and free of oil. After installation, thoroughly clean pipes with a soft cloth and soapy water that will leave no residue (chrome wax, polish, glass cleaner, alcohol, ammonia, etc.) before starting the motorcycle.
2. Avoid long periods of idling as this can cause discoloration.
3. Intake leaks can cause the engine to run lean and overheat, this could lead to discoloration.
4. Make sure there are no exhaust leaks at the junction of the exhaust pipes and the cylinder head. We recommend replacing gaskets if they are worn.

## EXHAUST CARE (BLACK)

1. When installing a new set of black pipes, make sure your hands are clean and free of oil. After installation, thoroughly clean pipes with warm soapy water and a soft cloth. Dry with a clean towel to remove any residue before starting the motorcycle. Do NOT use anything abrasive to clean pipes.
2. Avoid long periods of idling as this can cause discoloration.
3. Intake leaks can cause the engine to run lean and overheat, this could lead to discoloration.
4. Make sure there are no exhaust leaks at the junction of the exhaust pipes and cylinder head. We recommend replacing gaskets if they are worn.

**FIGURE 1 (LEFT SIDE)**

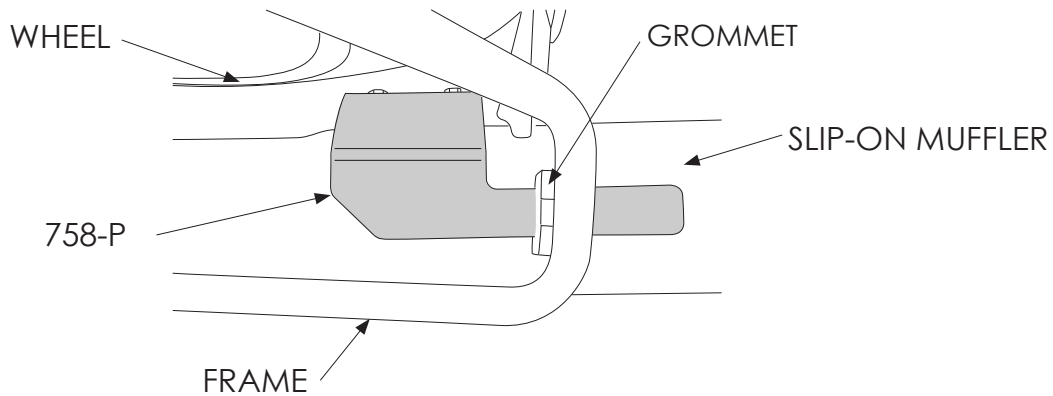

**FIGURE 2 (CLAMP DIRECTION)**

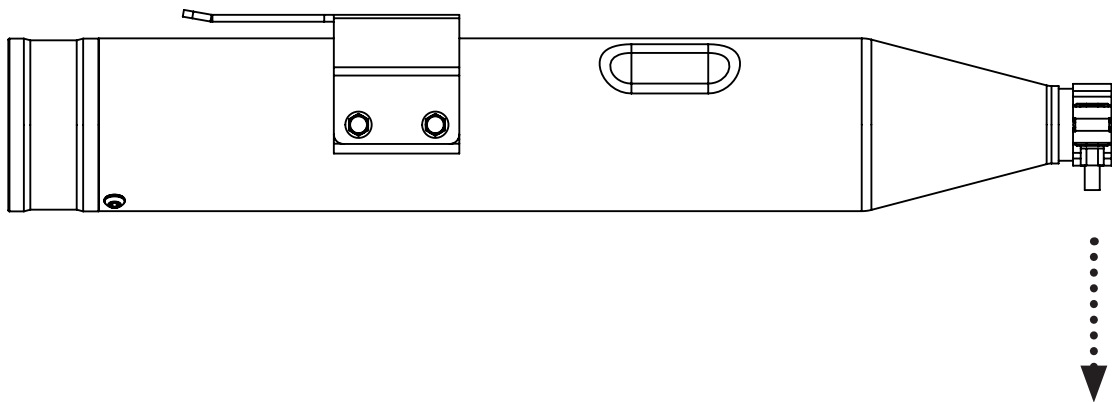

**Emissions Notice:**

In California, in order to meet Air Resources Board emissions requirements, certain aftermarket part applications have been identified as replacements, and others have received ARB Executive Orders. All other emissions related aftermarket parts are for competition use only.

**Warranty:**

All Vance & Hines products are warranted against defects in material and workmanship for a period of 90 days. This warranty does not cover discoloration or rust. This warranty shall be limited to the repair or replacement of the product, which may be proven defective under normal use. Vance & Hines will not warranty any system that has been abused, misused, improperly installed or modified.

Dealers or distributors are not authorized to make dispositions binding upon Vance & Hines. Vance & Hines will not be responsible for any labor charges incurred in removing or replacing any system under warranty. A return authorization number and a copy of the original purchase invoice must accompany all returns. Parts returned without a return authorization may be refused.