



Dyna Big Shots Staggered Exhaust System

Part #17911

Congratulations, you have purchased the finest exhaust system available for your motorcycle. Your VANCE & HINES exhaust system is designed and crafted for maximum performance, a perfect fit, a great sound and unbeatable style!

Attention Installer: (if other than owner): Please forward this instruction sheet to the purchaser of this product. These instructions contain valuable information necessary to the end user.



STOCK EXHAUST SYSTEM REMOVAL

1. Loosen heat shield clamps on both the front and rear head pipes.
2. If equipped, loosen crossover pipe clamp, located between front and rear head pipes.
3. Remove two cylinder exhaust port flange nuts from each head pipe, located at the cylinder head.
4. Remove both front and rear head pipe clamp bolts.
5. Remove the bolts that attach mufflers to the frame.
6. Remove the complete exhaust system and set aside. Assistance may be required.
7. Remove rear head pipe clamp bracket from transmission cover. Save the bolts as one of them will be reused.

8. Remove bolt below left side of the transmission cover. Position mounting bracket 338 over mounting location to determine which bolt will be removed. (Figure 1).
9. Carefully remove the cylinder exhaust port flanges and circlips from the stock exhaust system using snapping pliers. **NOTE: Replace bent or damaged circlips. Check exhaust port gasket condition.** (Recommended replacement exhaust port gaskets, Screamin' Eagle part number: 17048-98.)

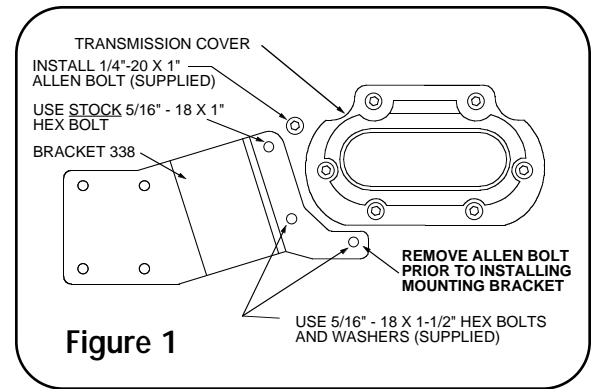

Figure 1

VANCE & HINES EXHAUST SYSTEM INSTALLATION

1. Attach mounting bracket 338 (supplied) to transmission using stock bolt in top hole. Install two 5/16" x 1-1/2" hex bolts and 5/16" flat washer combinations in remaining two holes. (hardware supplied). (Figure 1)
2. Replace unused stock mount bolt with 1/4"-20 x 1" Allen head bolt. (hardware supplied). (Figure 1)
3. Remove head pipes and heat shields from protective packaging. **Note:** Removal of end cap may be required. Place each heat shield on a non-abrasive surface such as a blanket or carpet. Using a felt tip pen, mark outside edge of each heat shield to show location of hose clamp mounting clips. (Figure 2)
4. Slide header into heat shields tail end first, engaging end caps. (Figure 3)
5. Install end caps (if removal was necessary) into tail end of each heat shield engaging head pipe and heat shield. Align mounting hole with end cap hole. Install and tighten 1/4"-20 button head screws. **Note:** Removable thread locking compound is recommended.
6. Install each hose clamp by feeding tail ends of clamps into heat shield clips. Take note of location of clamp screw head. (Figure 2&4) (screw head should be accessible when system is installed on motorcycle for adjustment purposes.) (Figure 4)
7. Install cylinder exhaust port flanges and circlips (from stock system) onto head pipes. (Figure 5)
8. Install the head pipe/heat shield assembly into exhaust port using stock nuts, do not tighten at this time.
9. Slide nut plates inside bracket that is welded to backside of head pipe. While holding nut plates in place attach head pipe to mounting bracket 338 using four 5/16" flange head bolts (supplied). Leave them loose at this time. (Figure 6)

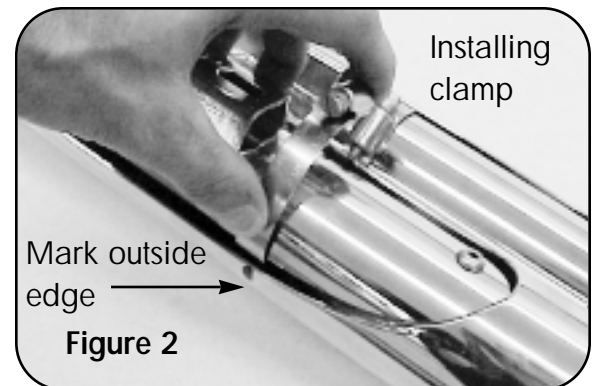

Figure 2



Figure 3

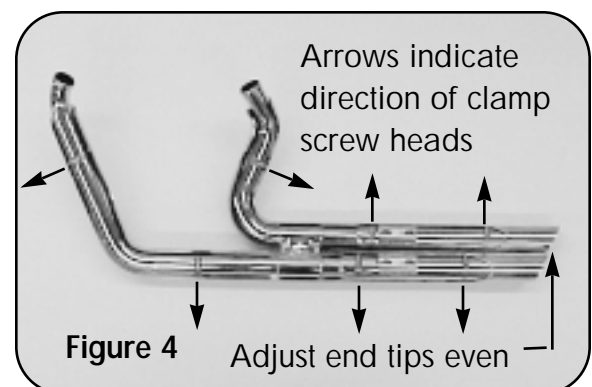
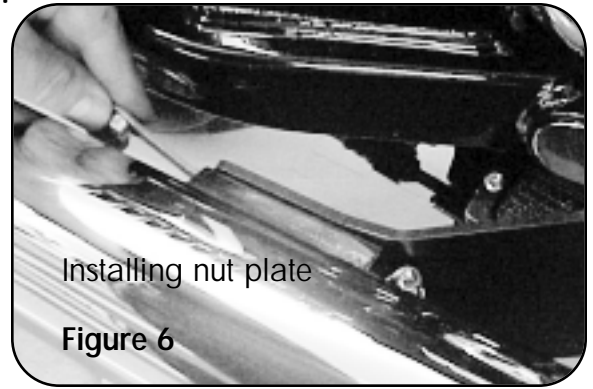
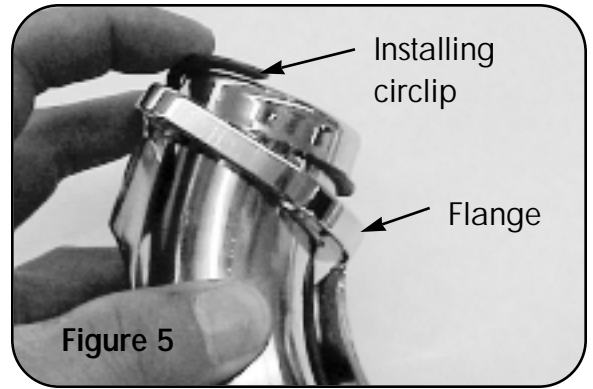

Figure 4

10. Tighten cylinder port exhaust flange nuts on front and rear cylinders.
11. Tighten flange bolts on both head pipe brackets.
12. Align heat shields so the end of the pipes line up evenly when viewed from the right hand side of the motorcycle. Tighten all hose clamps securing heat shields.
13. Check for adequate clearance between all exhaust system components and motorcycle accessories prone to heat damage.
14. **Be sure to tighten all hardware before starting motorcycle.**



RE-JETTING INSTRUCTIONS

Re-jetting the carburetors will result in realizing the "full" potential of this performance exhaust system.. Vance & Hines offers jet kits for most applications. For fuel injected models, we recommend the use of Vance & Hines Fuelpak part number 61005.

PLEASE NOTE:

Every effort is made for Vance & Hines Exhaust Systems to provide improved cornering clearance. However, due to design and space limitations on some motorcycle models, ground and cornering clearance may not be improved and in some cases may be reduced. Be sure to follow proper installation instructions.

Option

On fuel injected models this system will work with Vance & Hines Fuelpak part number 61005.

Option

Vance & Hines also offers Quiet baffles for this system, part number 21869. This will lower the sound level 2-3db on average.

PACKING LIST (All parts actual size)

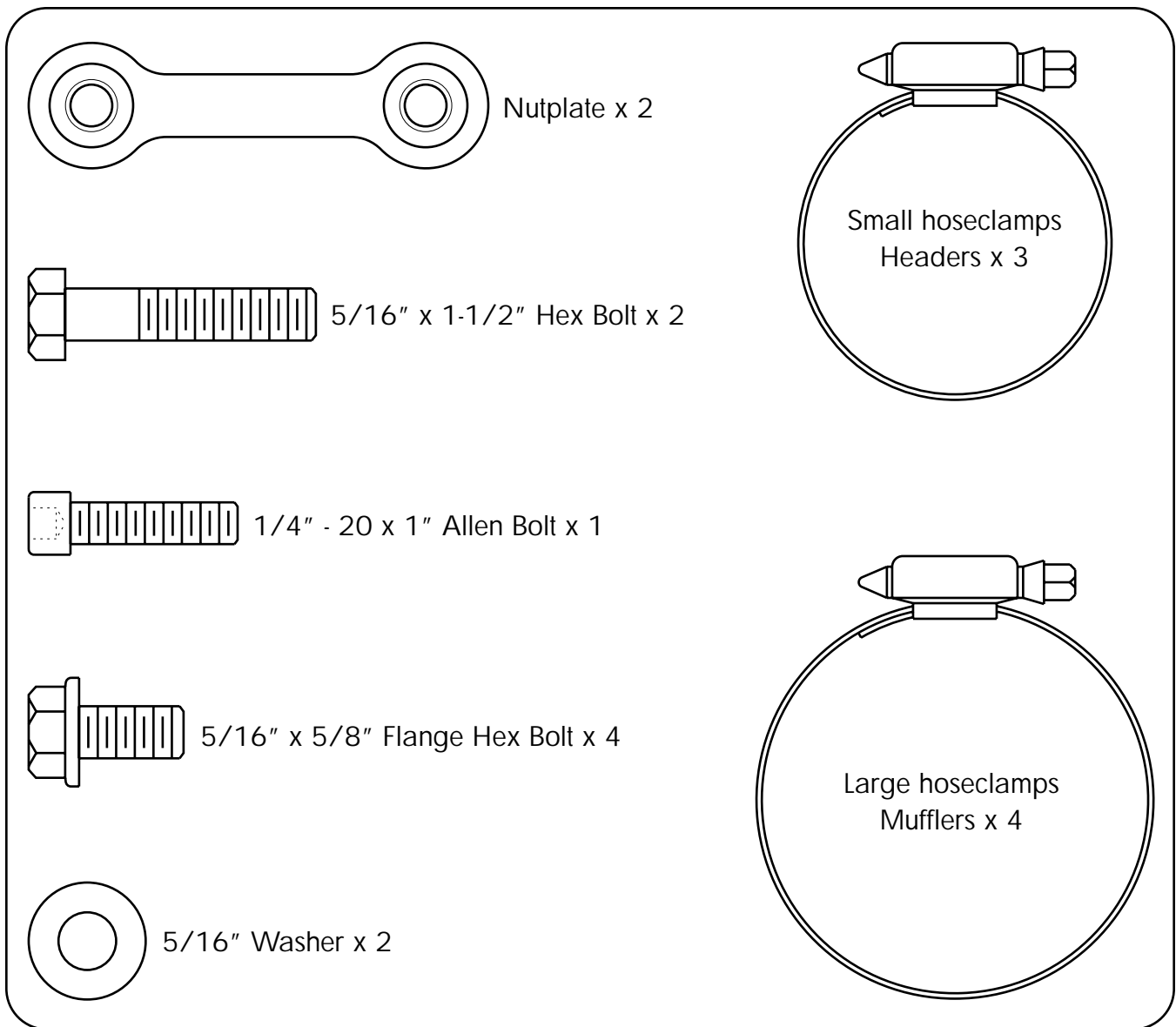

HELPFUL HINTS TO AVOID DISCOLORATION OF EXHAUST PIPES

1. Follow owner's manual instructions regarding use of the choke (starter enricher). If left on longer than recommended, discoloration may be accelerated.
2. Avoid long periods of idling.
3. Intake leaks can cause engine to run lean and overheat, thus turning the pipes blue.
4. Make sure there are no exhaust leaks at the junction of the exhaust pipe and cylinder head.
5. When installing a new set of chrome pipes, make sure your hands are clean and free of oil. After installation, thoroughly clean pipes with a cleaning solvent that will leave no residue (glass cleaner, alcohol, ammonia, etc.) before starting the motorcycle.

WARNING!

VANCE & HINES DOES NOT WARRANTY ANY CHROME PRODUCTS AGAINST DISCOLORATION.

Vance & Hines puts everything within reach.