

SELF CANCELLING TURN SIGNAL MODULE

TURN SIGNAL SYSTEM AND HAZARD WARNING SYSTEM

INSTALLATION INSTRUCTIONS

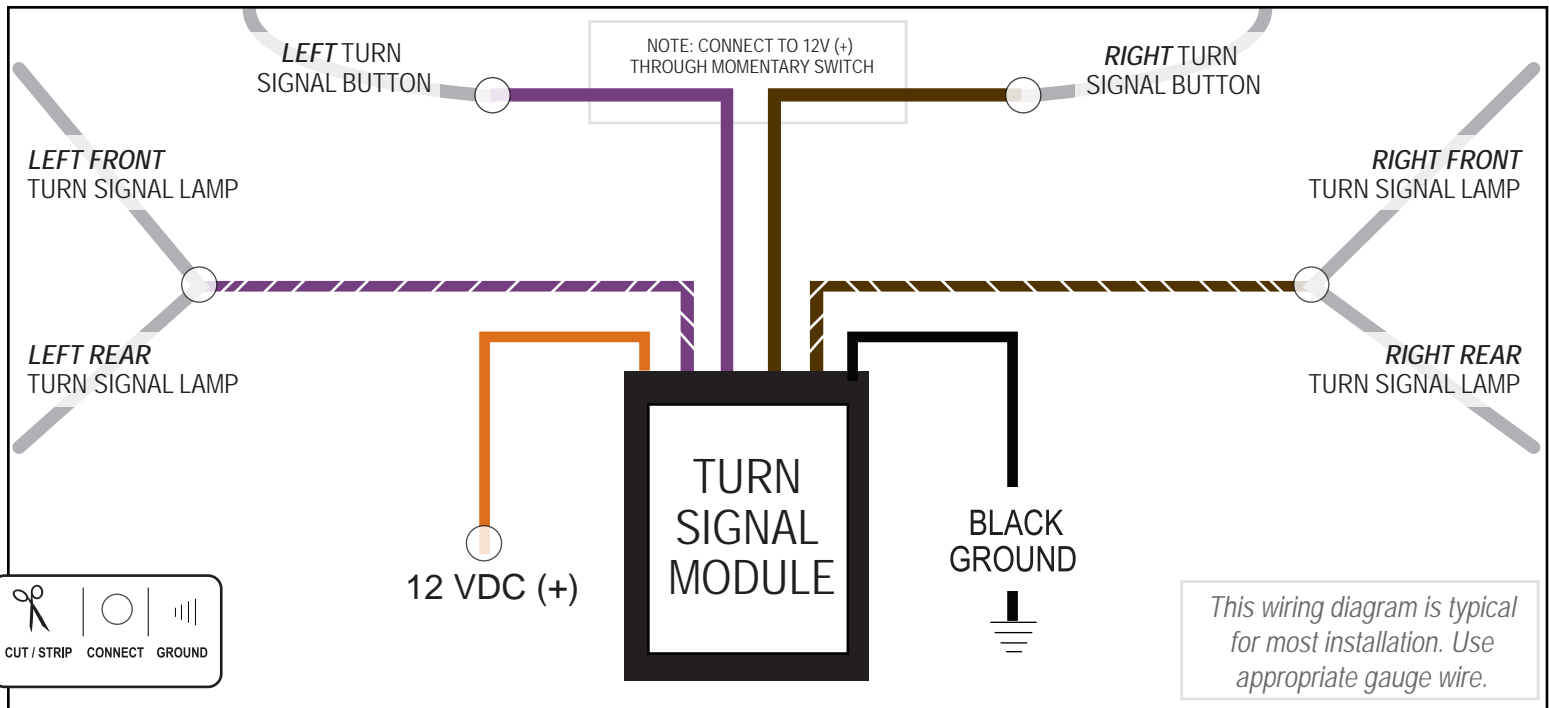

Step 1:

Follow wiring diagram by connecting all module wires to indicated wires above.

Step 2:

After installation is complete, refer to modes of operation below and test to ensure proper function.

FUNCTION CHECK: *Four Turn Signal Modes of Operation*

- Mode 1:** Press turn signal button for 1 second, turn signal lights will flash for 7 seconds, then self-cancel.
- Mode 2:** Press turn signal button for 2 seconds, turn signal lights will flash for 20 seconds, then self cancel.
- Mode 3:** Press turn signal button for 4 seconds, turn signal lights will flash for 75 seconds, then self-cancel.
Note : All three modes above can be cancelled by pressing the same turn signal button a second time.
- Mode 4:** Hazard Mode - is available all the time and will flash until cancelled. To engage, depress both the left and right turn signal buttons for 1 second. To cancel, depress both buttons again for one second.

Hardware Requirements: Two independent momentary turn signal switches are required. The module will not work with latching type toggle switches.

Circuit Protection: It is highly recommended that the turn signal circuit be protected with a 10 amp fuse or circuit breaker in the power supply lead (orange wire).

Mounting: It is recommended that the module be mounted in a location not subject to extreme heat conditions. It can be mounted with the included double sided adhesive tape or any other suitable means