

TOOLS NEEDED: 17MM OPEN END WRENCH CLEAN CLOTH MILD SOLVENT OR CLEANER

PLEASE READ THROUGH AND UNDERSTAND THESE INSTRUCTIONS BEFORE BEGINNING.

THE HONDA MASTER CYLINDER COVER IS DESIGNED TO FIT OVER THE EXISTING FRONT MASTER CYLINDER RESERVOIR. IF YOU HAVE OTHER ACCESSORIES MOUNTED TO THE HANDLEBARS NEAR THE MASTER CYLINDER YOU MAY NEED TO RELOCATE THEM TO INSTALL THE MASTER CYLINDER COVER. IT IS IMPORTANT THAT THE INSTALLATION INSTRUCTIONS ARE FOLLOWED CORRECTLY OR AN IMPROPER FIT MAY RESULT.

INSTALLATION: REFER TO DIAGRAMS 1 AND 2

1. PARK THE MOTORCYCLE ON LEVEL GROUND AND MAKE CERTAIN THAT IT IS IN A STABLE POSITION.
2. USE THE 17MM OPEN END WRENCH TO LOOSEN THE LOCK NUT ON THE MIRROR. REMOVE THE MIRROR BY UNTHREADING THE STEM FROM THE MASTER CYLINDER.
3. CLEAN THE MASTER CYLINDER AND THE MOUNTING CLAMP WITH A CLEAN, LINT FREE CLOTH AND A MILD SOLVENT OR CLEANER SUCH AS RUBBING ALCOHOL.
4. TEST FIT THE MASTER CYLINDER COVER. DO NOT REMOVE THE BACKING FROM THE MOUNTING TAPE ON THE INSIDE OF THE COVER YET. MAKE CERTAIN THE COVER DOES NOT INTERFERE WITH ANY CONTROLS OR ACCESSORIES. YOU MAY NEED TO ADJUST THE LOCATION OF THE MASTER CYLINDER OR ACCESSORIES TO PROVIDE SUFFICIENT CLEARANCE.

NOTE: IF YOU ARE ALSO INSTALLING A 55-357 CLAMP COVER CHECK THE FIT OF THE CLAMP COVER AND THE MASTER CYLINDER COVER TOGETHER BEFORE TAPING THEM IN PLACE.

5. REMOVE THE BACKING FROM THE MOUNTING TAPE ON THE INSIDE OF THE MASTER CYLINDER COVER. PLACE IT OVER THE MASTER CYLINDER AND MAKE ANY FINAL ADJUSTMENTS TO THE POSITION. WHEN THE COVER IS PROPERLY LOCATED PRESS FIRMLY ON THE TOP OF THE COVER SO THE MOUNTING TAPE ADHERES FULLY TO THE SURFACE OF THE MASTER CYLINDER. THE TAPE SHOULD BE ALLOWED TO SET FOR 72 HOURS BEFORE WASHING OR EXPOSURE TO WATER.
6. REINSTALL THE MIRROR AND TIGHTEN THE LOCKNUT. DIAGRAM 2 SHOWS THE COMPLETED ASSEMBLY.

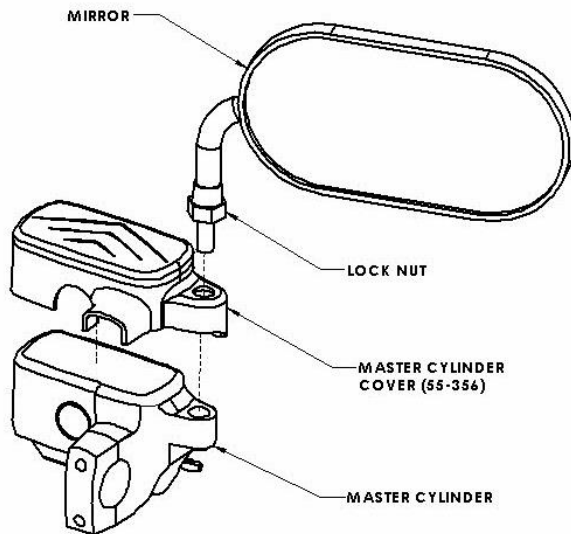

DIAGRAM 1

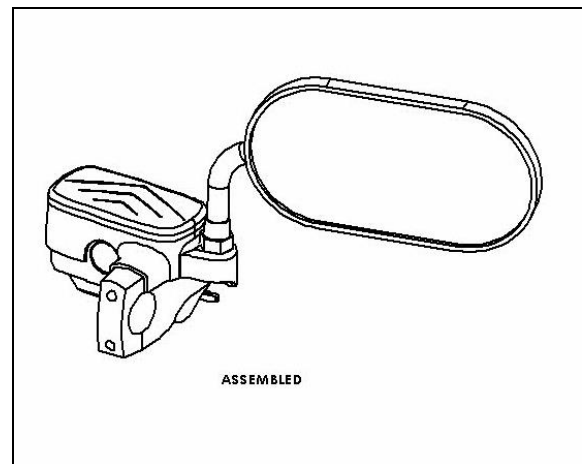

DIAGRAM 2