

TOOLS NEEDED:	#2 PHILLIPS SCREWDRIVER DRILL	13MM SOCKET WRENCH 13/16" DRILL BIT THREADLOCK COMPOUND	12MM WRENCH 2MM ALLEN WRENCH 10MM WRENCH	5MM ALLEN WRENCH 4MM ALLEN WRENCH	6MM ALLEN WRENCH 8MM WRENCH
HARDWARE INCLUDED:	(3) M6-1.0 X 16MM LONG BUTTON SOCKET HEAD CAP SCREW (2) M8-1.25 X 55MM LONG HEX HEAD FLANGE SCREWS (3) M6 LOCK WASHER (2) 4MM SPACER (2) M8-1.25 HEX NUT (2) M8 FLAT WASHER		(2) M8 LOCK WASHER *(4) M4-0.7 X 6MM LONG CUP POINT SOCKET HEAD SET SCREW *(2) M4-0.7 X 3MM LONG CUP POINT SOCKET HEAD SET SCREW *(2) M6-1.0 X 15MM LONG BUTTON SOCKET HEAD CAP SCREW *NOTE: THESE SCREWS ARE INCLUDED IN TURN SIGNAL ADAPTER KIT*		

NOTE: THREAD LOCK COMPOUND SHOULD BE USED ON ALL HARDWARE

PLEASE READ THROUGH AND UNDERSTAND THESE INSTRUCTIONS BEFORE BEGINNING.

INSTALLATION (SEE DIAGRAM 1)

1. DISCONNECT THE NEGATIVE BATTERY CABLE.
2. USING AN 8MM WRENCH, REMOVE THE TWO SCREWS ON THE SIDE OF THE HEADLIGHT AND REMOVE THE HEADLIGHT.
3. ON EACH OEM TURN SIGNAL FOLLOW THE WIRES INTO THE HEADLIGHT HOUSING AND DISCONNECT THEM. UNPLUG THE ORANGE AND BLUE CONNECTORS.
4. USING A 12MM WRENCH REMOVE THE TWO M8 NUTS (B) UNDER THE LOWER FORK ASSEMBLY WHICH HOLDS THE OEM HEADLIGHT BRACKET. (NOTE: THESE BOLTS WILL NOT BE REUSED BUT THE NUT (B) WILL BE REUSED.
5. REMOVE THE CHROME TURN SIGNAL HOUSING AND MAKE SURE TO PULL THE TURN SIGNAL WIRES THROUGH THE HEADLIGHT HOUSING.
6. USING AN 8MM WRENCH REMOVE THE TWO BOLTS THAT HOLD THE MOUNTING PLATE TO THE TURN SIGNAL HOUSING. (NOTE: THESE WILL NOT BE REUSED)

NOTE: STEPS 7, 8, 9, 10, 14, 15, 16, & 17 ARE FOR INSTALLING OEM TURN SIGNALS WITH PURCHASE OF 55-122T ADAPTERS.

7. USING AN 8MM WRENCH REMOVE THE TWO BOLTS GOING THROUGH THE FRONT OF THE TURN SIGNAL HOUSING. (NOTE: THESE WILL NOT BE REUSED)
8. USING A PHILLIPS SCREWDRIVER REMOVE THE TWO SCREWS HOLDING EACH TURN SIGNAL INTO THE HOUSING. (NOTE: THESE WILL NOT BE REUSED)
9. PULL THE TURN SIGNALS OUT OF THE HOUSING AND PULL THE WIRES ALL THE WAY OUT TOO.
10. USING A 5MM ALLEN WRENCH REMOVE THE BRACKET FROM THE TURN SIGNAL. MAKE SURE YOU MARK THE TURN SIGNALS LEFT AND RIGHT TO GET THEM ON THE NEW LIGHT BAR CORRECTLY.
11. PUT THE NEW M8-1.25 X 55MM LONG HEX HEAD FLANGE SCREWS (A) PROVIDED IN THE HEADLIGHT BRACKET AND THROUGH THE FORK BRACKET.
12. INSTALL THE MOUNTING PLATE (E) TO THE FORK USING SPACERS (J) PROVIDED AND THE M8 NUTS (B) REMOVED IN STEP 4. (NOTE: THE SPACERS GO BETWEEN THE FORKS AND THE MOUNTING PLATE (E).
13. INSTALL THE NEW LIGHTS (I) ONTO THE LIGHT BAR (D) USING THE THREADED STEM (P) AND FLAT WASHER, LOCK WASHER, AND NUT (F) PROVIDED WITH LIGHTS. POSITION THE LIGHTS. TIGHTEN WITH A 13MM SOCKET. CONNECT THE GROUND WIRE WITH THE RING TERMINAL TO ONE OF THE M6-1.0 X 16MM BUTTON SOCKET HEAD CAP SCREWS. THE BLUE WIRE WITH THE BULLET CONNECTOR WILL CONNECT TO THE NEW WIRE HARNESS PROVIDED.
14. INSTALL EACH OEM TURN SIGNAL (G) ONTO THE TURN SIGNAL ADAPTER *(H) ROUTING THE WIRES THROUGH THE EXTRA HOLE IN THE ADAPTER. THEN USING THE M6-1.0 X 15MM LONG BUTTON SOCKET HEAD CAP SCREW *(L) SECURE THE TURN SIGNAL TO THE ADAPTER.
15. ROUTE THE OEM TURN SIGNAL WIRES AND THE LIGHT WIRES INTO THE LIGHT BAR. (NOTE: YOU MAY HAVE TO CUT OFF THE OEM CONNECTORS AND RE-CONNECT THEM AFTER ROUTING)
16. THE TURN SIGNAL ADAPTER *(H) WITH THE OEM TURN SIGNAL (G) CAN BE POSITIONED INTO THE LOWER ENDS OF THE LIGHT BAR (D) AND SECURED WITH THE SET SCREWS *(K). THERE ARE THREE SET SCREWS ON EACH SIDE.
17. USING THE M6-1.0 X 16MM LONG BUTTON SOCKET HEAD CAP SCREWS AND LOCK WASHERS (C) ATTACH THE LIGHT BAR (D) ONTO THE MOUNTING PLATE (E). TIGHTEN SECURELY WITH A 4MM ALLEN WRENCH.
18. RE-ROUTE THE TURN SIGNAL WIRES INTO THE HEADLIGHT HOUSING AND RE-CONNECT AS THEY WERE.
19. LOCATE YOUR BIKES BATTERY, FUSE BLOCK AND/OR ACCESSORY TERMINAL AND WIRE USING DIAGRAM 2.

NOTE: IF SWITCH BLOCK 13-207 OR 52-605 IS PURCHASED, STEPS C & E CAN BE SKIPPED AND PLUG ONE OF THE SWITCHES INTO THE RELAY.

- A. CONNECT THE BULLET CONNECTORS ON THE BLACK WIRES TO THE BLUE WIRES ON THE LIGHTS.
- B. WIRE THE GREEN AND THE RED WIRE WITH THE IN LINE FUSE DIRECTLY TO THE BATTERY. RED TO POSITIVE (+) AND GREEN TO GROUND (-).
- C. FIND A PLACE TO INSTALL THE SWITCH. DRILL A PILOT HOLE FIRST AND THEM A 13/16" (20.6MM).

- D. ROUTE THE WIRE HARNESS AND PLUG THE THREE SPADE CONNECTORS INTO THE SWITCH AS SHOWN IN DIAGRAM 2.
- E. CONNECT THE RING TERMINAL TO THE BATTERY GROUND AND SPLICE THE T-TAP INTO A KEYED POWER SOURCE AND CONNECT THE MALE SPADE CONNECTOR.
- F. CONNECT THE REMAINING FIVE LEADS TO THE RELAY PER DIAGRAM 2.

20. TEST LIGHTS FOR PROPER OPERATION BEFORE REINSTALLING ANY REMOVED SIDE COVERS, SEATS, ETC. SECURE RELAY TO IT FROM MOVING.

DIAGRAM 1

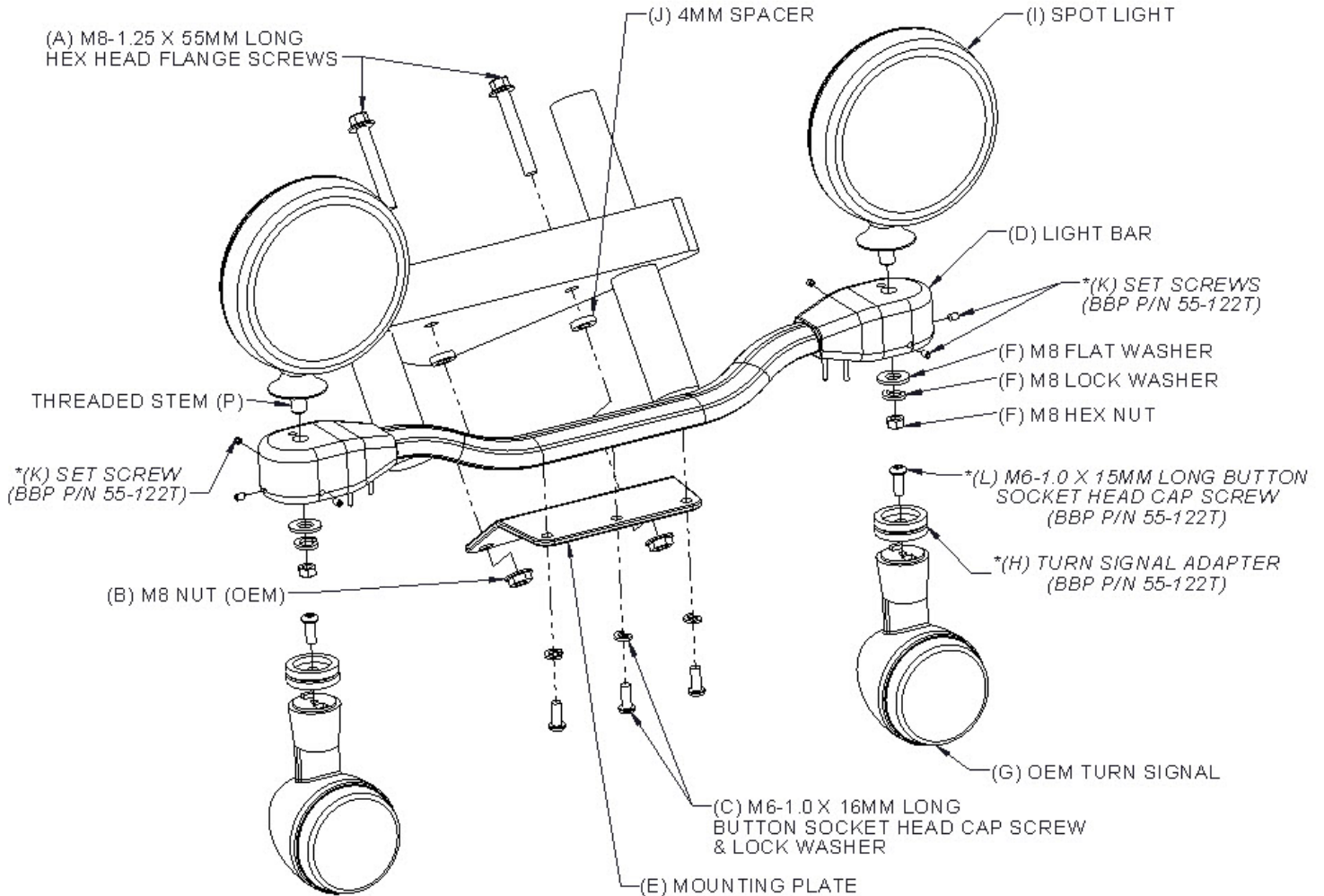

53-452

DIAGRAM 2

