

PART NO. 53-132 / 53-132L

ELLIPTICAL DRIVING KIT

HONDA VT1100 SABRE & AERO 1999-08; VT750 ACE 1998-03

TOOLS NEEDED:	#2 PHILLIPS SCREWDRIVER	13MM WRENCH 13/16" DRILL BIT	8MM WRENCH 4MM ALLEN WRENCH	5MM ALLEN WRENCH THREADLOCK COMPOUND	2MM ALLEN WRENCH DRILL
HARDWARE INCLUDED:	(3) M6-1.0 X 16MM LONG BUTTON SOCKET HEAD CAP SCREW-"C" (4) M4-0.7 X 6MM LONG CUP POINT SOCKET HEAD SET SCREW-"K" (2) M8-1.25 NYLON LOCKING HEX NUT-"F" (2) M8 LOCK WASHER-"N"			(2) M4-0.7 X 3MM LONG CUP POINT SOCKET HEAD SET SCREW-"L" (2) M6-1.0 X 15MM LONG BUTTON SOCKET HEAD CAP SCREW-"J" (3) M6-1.0 X 18MM LONG SOCKET HEAD CAP SCREW-"B" (5) M6 LOCK WASHER-"M"	

NOTE: THREAD LOCK COMPOUND SHOULD BE USED ON ALL HARDWARE.

PLEASE READ THROUGH AND UNDERSTAND THESE INSTRUCTIONS BEFORE BEGINNING.

INSTALLATION (SEE DIAGRAM 1)

1. DISCONNECT THE NEGATIVE BATTERY CABLE.
2. USING PHILLIPS SCREWDRIVER, REMOVE THE TWO SCREWS ON THE SIDE OF THE HEADLIGHT AND REMOVE THE HEADLIGHT.
3. ON EACH FRONT OEM TURN SIGNAL FOLLOW THE WIRES INTO THE HEADLIGHT HOUSING AND DISCONNECT THEM (UNPLUG THE BULLET CONNECTORS).
4. USING 8MM WRENCH REMOVE THE OEM TURN SIGNALS AND THE MOUNT.
5. USING THE TWO M6-1.0 X 18MM LONG SOCKET HEAD CAP SCREWS (B) AND LOCK WASHERS PROVIDED (M) INSTALL THE NEW MOUNTING PLATE (A) IN PLACE OF THE OEM TURN SIGNAL MOUNT. TIGHTEN SECURELY WITH A 5MM ALLEN WRENCH.
6. INSTALL THE NEW SPOT LIGHTS (E) ONTO THE LIGHT BAR (D) USING THE NYLOCK NUT (F) AND LOCK WASHER (N) PROVIDED WITH THE LIGHTS. POSITION THE LIGHTS. TIGHTEN WITH A 13MM WRENCH. CONNECT THE GROUND WIRE WITH THE RING TERMINAL TO THE M6 - 1.0 X 15MM LONG (J) SOCKET HEAD CAP SCREW AND THE POSITIVE WIRE WITH BULLET CONNECTOR WILL GO INTO THE EXTRA HOLE ON TOP OF LIGHT BAR.

NOTE: STEPS 7,8,9,10, & 12 ARE FOR INSTALLING OEM TURN SIGNAL WITH PURCHASE OF 55-122T ADAPTER.

7. TO RELOCATE THE OEM TURN SIGNALS (G) REMOVE THEM FROM THE OEM MOUNTING BAR USING A #2 PHILLIPS SCREWDRIVER AND REMOVE THE L-BRACKETS USING A 5MM ALLEN WRENCH.
8. INSTALL EACH OEM TURN SIGNAL (G) ONTO THE TURN SIGNAL ADAPTER (H) ROUTING THE WIRES THROUGH THE EXTRA HOLE IN THE ADAPTER. THEN TIGHTEN THE M6 - 1.0 X 15MM LONG BUTTON SOCKET HEAD CAP SCREW (J) WITH A 5MM ALLEN WRENCH.
9. ROUTE THE TURN SIGNAL (G) WIRES AND THE SPOT LIGHT (E) WIRE INTO THE LIGHT BAR (D).
10. THE TURN SIGNAL ADAPTER (H) WITH OEM TURN SIGNAL (G) CAN BE POSITIONED INTO THE LOWER ENDS OF THE LIGHT BAR (D) AND SECURED WITH THE SET SCREWS (K & L). THERE ARE THREE SET SCREWS ON EACH SIDE. (SEE DIAGRAM 1)
11. USING THE M6 - 1.0 X 16MM LONG BUTTON SOCKET HEAD CAP SCREWS (C) AND LOCK WASHERS (M) INSTALL THE LIGHT BAR (D) ONTO THE MOUNTING PLATE (A). TIGHTEN SECURELY WITH A 4 MM ALLEN WRENCH.
12. RE-ROUTE THE OEM TURN SIGNAL WIRES INTO THE HEADLIGHT HOUSING AND RECONNECT AS THEY WERE.

WIRING INSTALLATION (SEE DIAGRAM 2)

NOTE: IF A 13-207/52-605/52-605L SWITCH BLOCK IS PURCHASED, STEPS C & E CAN BE SKIPPED AND PLUG ONE OF THE SWITCHES INTO THE RELAY.

- A) CONNECT THE BULLET CONNECTORS ON BLACK WIRES TO BULLET CONNECTORS ON LIGHT.
- B) WIRE SMALL GREEN AND RED HARNESS WITH IN-LINE FUSE DIRECTLY TO BATTERY: RED (+) POSITIVE, GREEN (-) NEGATIVE.
- C) FIND A CONVENIENT PLACE TO INSTALL THE SWITCH. DRILL A PILOT HOLE FIRST AND THEN DRILL A 13/16" HOLE. (CAN BE INSTALLED IN SIDE COVER.)
- D) ROUTE WIRE HARNESS AND PLUG THE THREE SPADE CONNECTORS TO SWITCH PER DIAGRAM: (GREEN=GROUND: ORANGE=SUPPLY: BLUE=LEAD.)
- E) CONNECT THE RING TERMINAL TO THE BATTERY GROUND AND SPLICE THE T-TAP INTO A KEYED POWER SOURCE AND CONNECT THE MALE SPADE.
- F) CONNECT THE REMAINING FIVE LEADS (2 BLACK, 1 RED, 1 BLUE, AND 1 GREEN) TO THE RELAY PROVIDED AS PER DIAGRAM 2.
- G) SECURE THE RELAY TO KEEP IT FROM BOUNCING AND GETTING DAMAGED.
- H) RECONNECT THE BATTERY GROUND CABLE.
- I) TEST LIGHTS FOR PROPER OPERATION BEFORE REINSTALLING ANY REMOVED SIDE COVERS, SEATS, ETC.

DIAGRAM 1

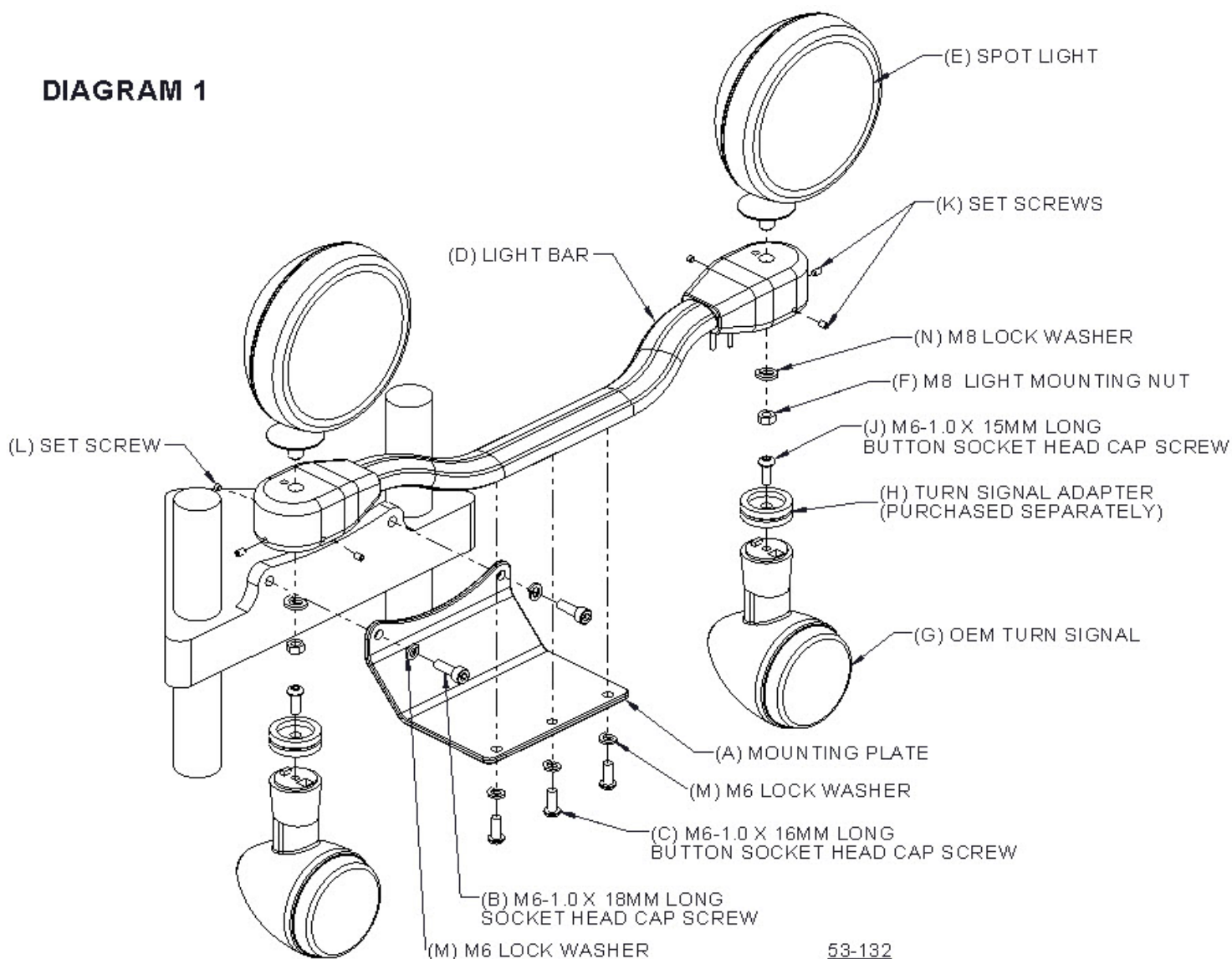

53-132

