

Copyright © 2018 by Big Bike Parts, Inc. No part of this instruction sheet may be reproduced without the written permission of Big Bike Parts, Inc.

PART NO. 52-926, 52-926BK

PASSENGER ARMREST

FITMENT:

HONDA GOLDWING/ GOLDWING TOUR 2018-NEWER

TOOLS NEEDED:	6MM ALLEN WRENCH	DRILL	1/4" DRILL BIT	SOCKET WRENCH	MASKING TAPE
	1/8" DRILL BIT	12MM SOCKET	4MM ALLEN WRENCH	REMOVABLE THREAD LOCK	

**PLEASE READ THROUGH AND UNDERSTAND THESE INSTRUCTIONS BEFORE BEGINNING. "USE REMOVABLE THREAD LOCK ON ALL FASTENERS"**

**ESTIMATED INSTALLATION TIME: 60 TO 90 MIN.**

**INSTALLATION:**

1. WITH BOTH SADDLEBAGS OPEN, REMOVE THE SIDE PANELS BY PULLING THEM OUT ON THE FRONT (FIG. 1).
2. USE A 6MM ALLEN WRENCH TO REMOVE THE TWO SEAT BOLTS (FIG. 2 SHOWS LEFT SIDE).
3. DISCONNECT SEAT WIRE HARNESS PLUG LOCATED UNDER THE RIGHT SIDE PANEL (FIG. 3). REMOVE THE SEAT BY LIFTING UP ON THE FRONT OF THE SEAT AND PULLING TOWARDS THE FRONT OF THE BIKE.
4. USE A 12MM SOCKET TO REMOVE THE TWO BOLTS MOUNTING THE LEFT GRAB HANDLE TO THE BIKE FRAME (FIG. 4).
5. DISCONNECT THE CABLE ON THE LEFT HANDLE BY CAREFULLY PULLING THE WHITE CABLE HOLDER FROM THE HOLDING TABS ON THE INSIDE OF THE LEFT GRAB HANDLE (FIG. 5). ONCE CABLE HOLDER IS FREE, PULL THE TENSION SPRING BACK AND SLIDE THE CABLE OUT OF THE SLOTS IN THE LATCH (FIG. 5). REMOVE LEFT GRAB HANDLE AND SET ON A CLEAN SOFT SURFACE TO PREVENT SCRATCHING.
6. PLACE A PIECE OF MASKING TAPE ON THE INSIDE OF THE LEFT GRAB HANDLE AND MARK THE HOLE TO BE DRILLED (FIG. 6). DRILL A 1/4" HOLE AT THIS LOCATION.
7. USE FIG. 7 TO DETERMINE LEFT AND RIGHT SIDE ARM REST BASE. SET RIGHT ARM REST BASE ASIDE FOR NOW.
8. PLACE THE LEFT ARM REST BASE IN PLACE ON THE LEFT GRAB HANDLE AND INSERT THE M6 BOLT AND FLAT WASHER SUPPLIED WITH THE KIT TO HOLD THE ARM REST BASE IN PLACE (FIG. 8 SHOWS VIEW FROM BOTTOM). FROM THE BOTTOM SIDE OF THE ARM REST BASE, DRILL TWO 1/8" HOLES THROUGH THE LEFT GRAB HANDLE USING THE LEFT ARM REST BASE TO LOCATE THE HOLES (FIG. 8). BE CAREFUL WHEN DRILLING NOT TO DAMAGE THE THREADS IN THE ARM REST BASE WHILE DRILLING. REMOVE THE ARM REST BASE FROM THE GRAB HANDLE AND DRILL THE TWO HOLES AGAIN USING A 1/4" DRILL BIT.
9. ASSEMBLE THE LEFT ARM REST AS SHOWN IN FIG. 9. BOLT THE LEFT ARM REST ASSEMBLY TO THE LEFT GRAB HANDLE USING THE THREE M6 BOLTS AND ONE FLAT WASHER ON THE INSIDE BOLT (SHOWN IN FIG. 10).
10. REPEAT STEPS 4 AND 5 IN REVERSE ORDER TO RECONNECT THE CABLE TO THE LEFT GRAB HANDLE AND BOLT THE LEFT GRAB HANDLE AND ARM REST IN PLACE WITH THE 12MM SOCKET.
11. REPEAT STEPS 4 THROUGH 10 ON THE RIGHT SIDE. (THERE IS NO CABLE ON THE RIGHT GRAB HANDLE)
12. TO ADJUST EACH ARM REST USE A 6MM ALLEN WRENCH TO TIGHTEN THE PIVOT BOLT (SEEN IN FIG. 9). ONLY TIGHTEN ENOUGH TO HOLD ARMREST IN PLACE WHILE STILL ALLOWING ARM REST TO PIVOT AS NEEDED.
13. USE THE 6MM ALLEN WRENCH TO HOLD THE PIVOT BOLT FROM MOVING AND INSTALL BOTH SET SCREWS AND TIGHTEN (SEEN IN FIG. 9).
14. INSTALL THE CAPS WHEN ARM REST ARE AS DESIRED (SEEN IN FIG. 9).
15. REPEAT STEPS 1 THROUGH 3 IN REVERSE ORDER TO FINISH ASSEMBLING BIKE.

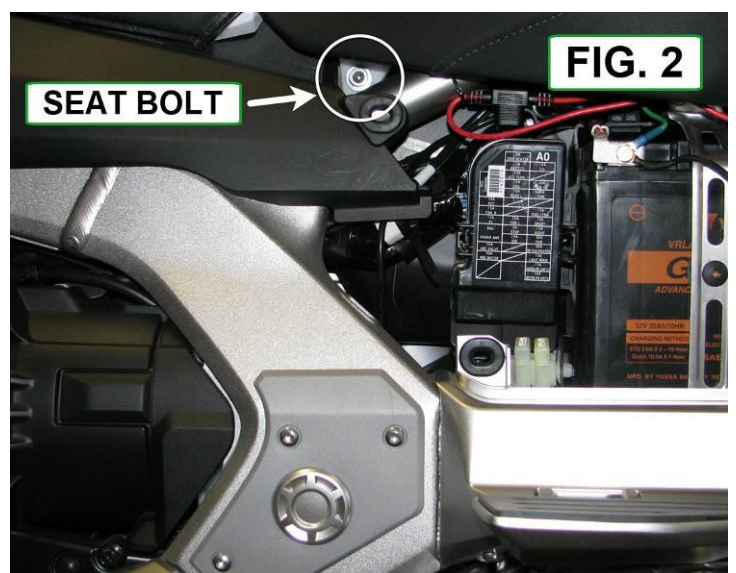

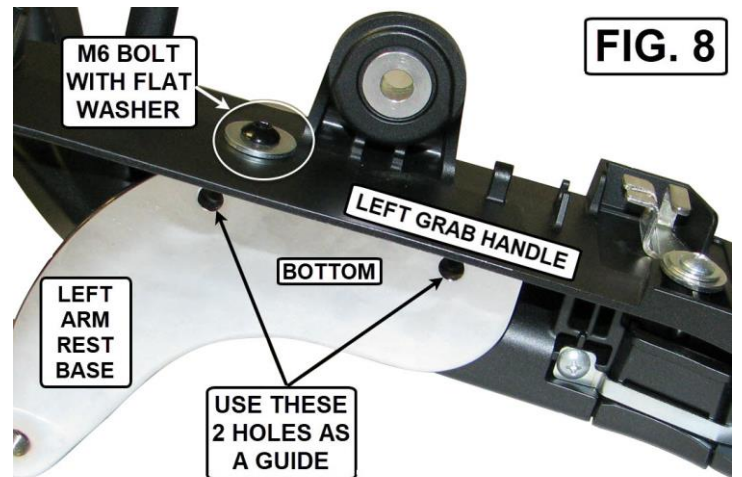
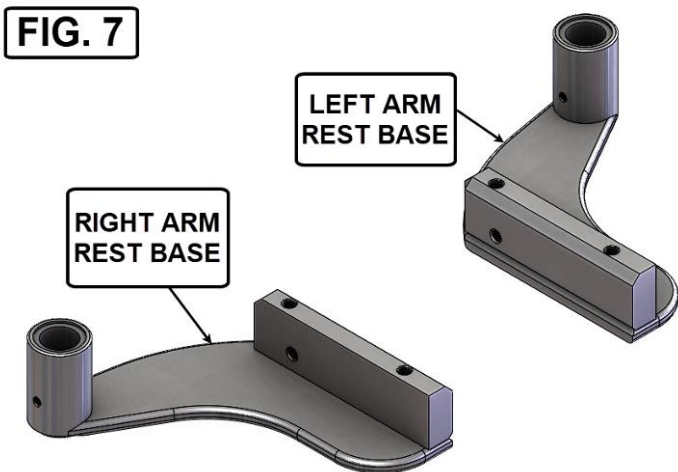
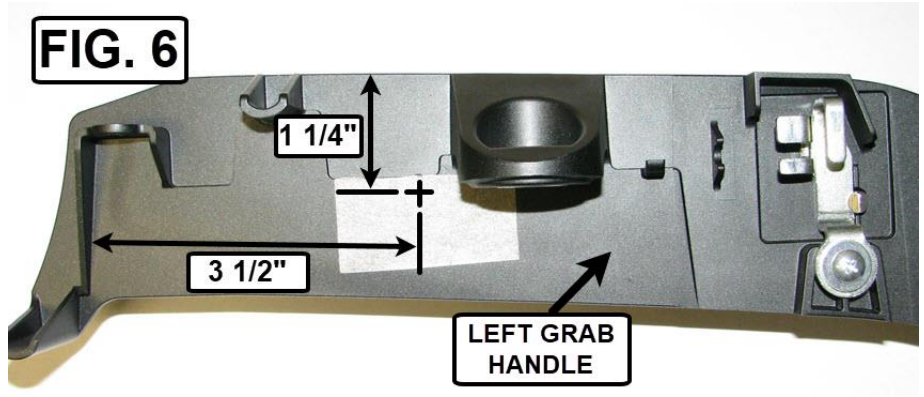
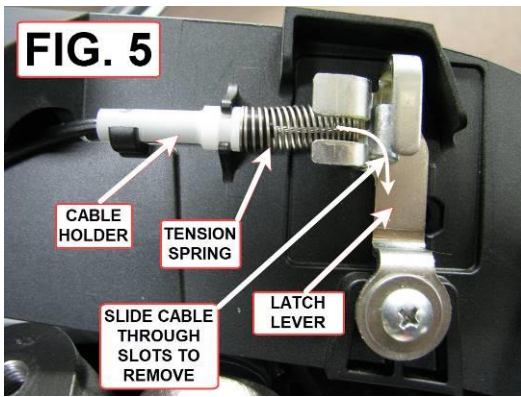
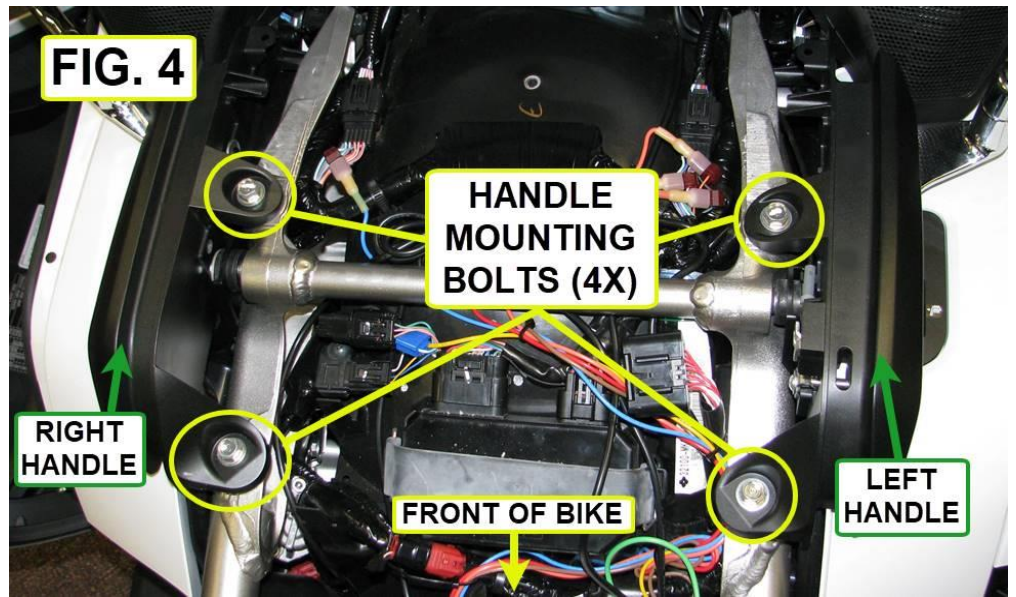
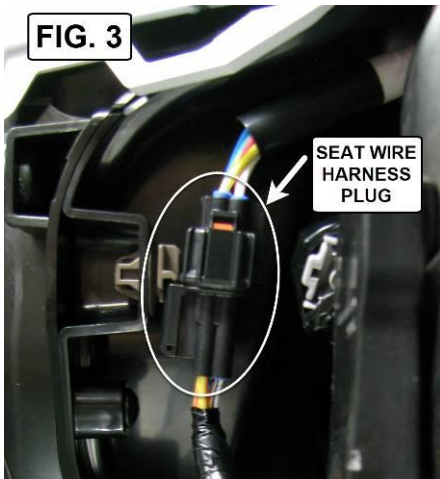

**FIG. 9**

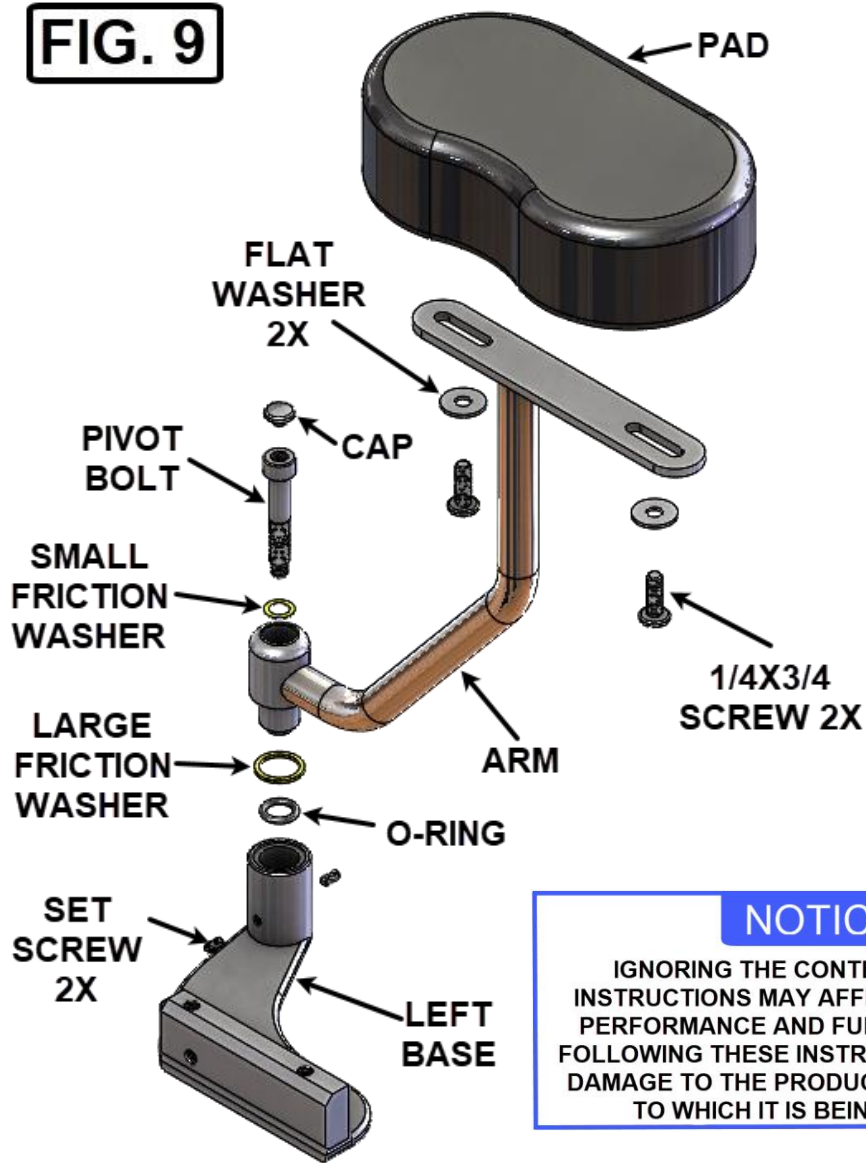

**NOTICE**  
IGNORING THE CONTENTS OF THESE INSTRUCTIONS MAY AFFECT THE PRODUCT PERFORMANCE AND FUNCTIONALITY. NOT FOLLOWING THESE INSTRUCTION MAY CAUSE DAMAGE TO THE PRODUCT OR THE VEHICLE TO WHICH IT IS BEING ATTACHED.

**FIG. 10**

