

PART NO. 52-920T

SMART MOUNT BACKREST

FITMENT:

HONDA GOLDWING TOUR CUSTOM SEAT 2018-NEWER

TOOLS NEEDED:	3MM ALLEN WRENCH	4MM ALLEN WRENCH	5MM ALLEN WRENCH	6MM ALLEN WRENCH	13MM WRENCH
	7/16" (11MM) WRENCH	RUBBING ALCOHOL	LINT FREE TOWEL	REMOVABLE THREAD LOCK	KNIFE/CUTTING BLADE

IF USING THIS BACKREST ON A STANDARD GOLDWING/GOLDWING TOUR SEAT YOU WILL NEED TO ALSO PURCHASE PART NUMBER 952920PC –INSERT PLUG COVER YOU SHOULD ALSO AND DOWNLOAD THE INSTALLATION INSTRUCTIONS FOR PART NUMBER 52-920.

PLEASE READ THROUGH AND UNDERSTAND THESE INSTRUCTIONS BEFORE BEGINNING.

USE REMOVABLE THREAD LOCK ON ALL FASTENERS

ESTIMATED INSTALLATION TIME: 30 TO 45 MIN.

INSTALLATION:

1. OPEN BOTH SADDLEBAGS AND REMOVE BOTH SIDE PANELS. PULL ON THE FRONT OF EACH PANEL TO REMOVE THEM. SEE FIG. 1.
2. USING A 6MM ALLEN WRENCH REMOVE THE TWO ALLEN BOLTS HOLDING THE SEAT ON. THERE IS ONE ON EACH SIDE TOWARD THE FRONT OF THE SEAT. SEE FIG. 2.
3. UNPLUG THE CONNECTOR FOR THE SEAT ON THE RIGHT SIDE SHOWN IN FIG. 3.
4. LIFT THE FRONT OF THE SEAT UP AND PULL IT FORWARD TO REMOVE IT. PLACE THE SEAT WITH THE BOTTOM UP ON A CLEAN SURFACE.
5. USE A RAZER KNIFE TO CUT THE FOAM FROM THE OPENING IN THE BOTTOM OF THE SEAT SHOWN IN FIG. 4. CUT ROUGHLY 1" OF FOAM AT A TIME WHILE PULLING THE PIECES OUT UNTIL THE FOAM IS CUT THROUGH UP TO THE VINYL. BE CAREFUL NOT TO CUT THE VINYL.
6. TURN THE SEAT OVER AND MARK THE CENTER OF THE SEAT AND THEN MEASURE FROM THE SEAM BACK 1 1/2" AND MARK THE SEAT. (FIG. 5)
7. REMOVE THE MASKING FROM THE PROTECTOR SUPPLIED IN THE KIT AND PLACE IT CENTERED OVER THE MARKS (FIG. 5) AND CUT A SLIT THROUGH THE VINYL THAT IS THE WIDTH OF THE OPENING ON THE PROTECTOR. (FIG. 5)
8. INSERT THE FOUR T-NUTS INTO THE SLOTS IN THE BOTTOM OF THE SEAT AS SHOWN IN FIG. 6. IF NEEDED USE SOME SMALL PIECES OF TAPE TO HELP HOLD THE T-NUTS IN PLACE.
9. THREAD THE TWO M8 X 16MM LONG SCREWS INTO THE BASE MOUNT AS SHOWN IN FIG. 7. PUT THE TWO SUPPLIED JAM NUTS ON THE OPPOSITE SIDE AS SHOWN IN FIG. 7. DO NOT TIGHTEN YET.
10. PLACE THE SUPPLIED RISER ON THE TWO SCREWS AS SHOWN IN FIG. 8. USING A 5MM ALLEN WRENCH AND A 13MM WRENCH ADJUST AND TIGHTEN THE SCREWS AND JAM NUTS SO THAT THE HEAD OF THE SCREW IS AS CLOSE AS POSSIBLE TO THE RISER BUT THE RISER WILL STILL SLIDE OFF OF THE SCREWS.
11. REMOVE THE MASKING FROM THE BACK OF THE RUBBER STRIP SUPPLIED IN THE KIT AND PLACE ON THE BOTTOM SIDE OF THE BASE MOUNT AS SHOWN IN FIG. 9.
12. PLACE THE ASSEMBLED BASE MOUNT ON THE BOTTOM OF THE SEAT AS SHOWN IN FIG. 10. INSTALL THE FOUR M6 X 20MM LONG ALLEN SCREWS WITH THE FOUR FLAT WASHERS AS SHOWN IN FIG. 10. PUSH THE BASE MOUNT TOWARD THE FRONT OF THE SEAT AS YOU TIGHTEN THE SCREWS.
13. ASSEMBLE THE RISER AND THE ADJUSTMENT PLATE AS SHOWN IN FIG. 11. USE THE TWO M6 X 18MM LONG SCREWS WITH A FLAT WASHER AND LOCK WASHER ON EACH SCREW.
14. ASSEMBLE THE RISER TO THE REST OF THE UPPER BACKREST AS SHOWN IN FIG. 12.
15. SLIDE THE RISER THROUGH THE HOLE IN THE SEAT AND ONTO THE TWO SCREWS IN THE BASE MOUNT AS YOU DID IN STEP 8. ADJUST THE ADJUSTMENT PLATE AND THE TOP BRACKET TO YOUR DESIRED POSITION AND MAKE SURE ALL HARDWARE HAS BEEN TIGHTENED.
16. SNAP THE POUCH TO THE BACKREST PAD.
17. REINSTALL SEAT AND SIDE PANELS.

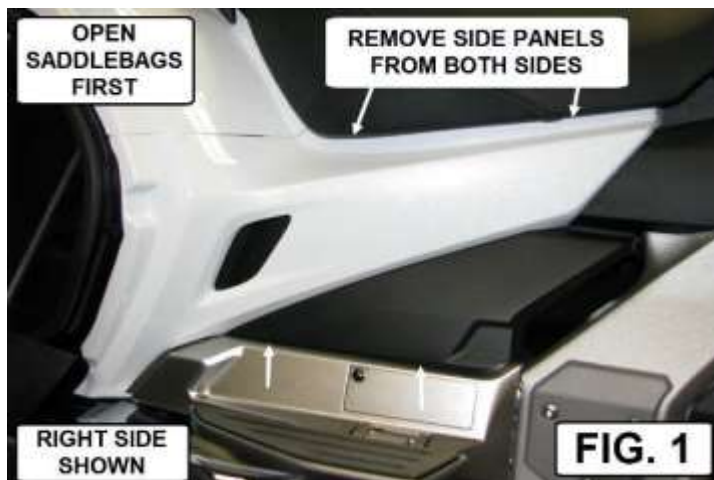

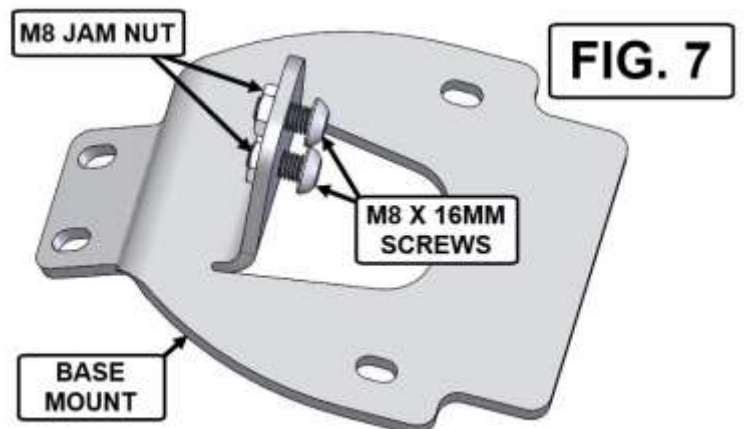
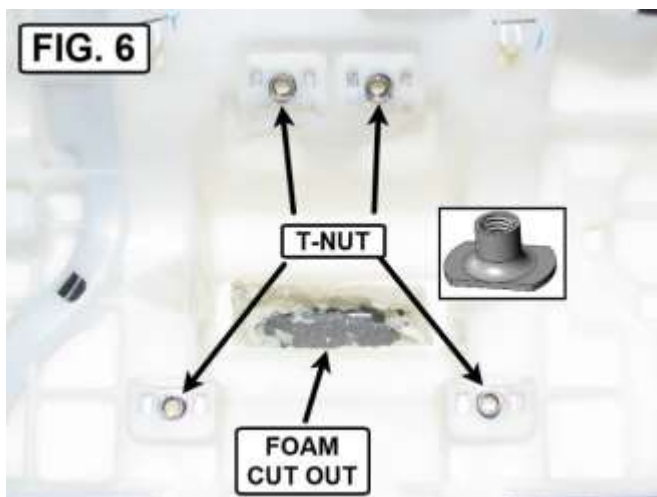
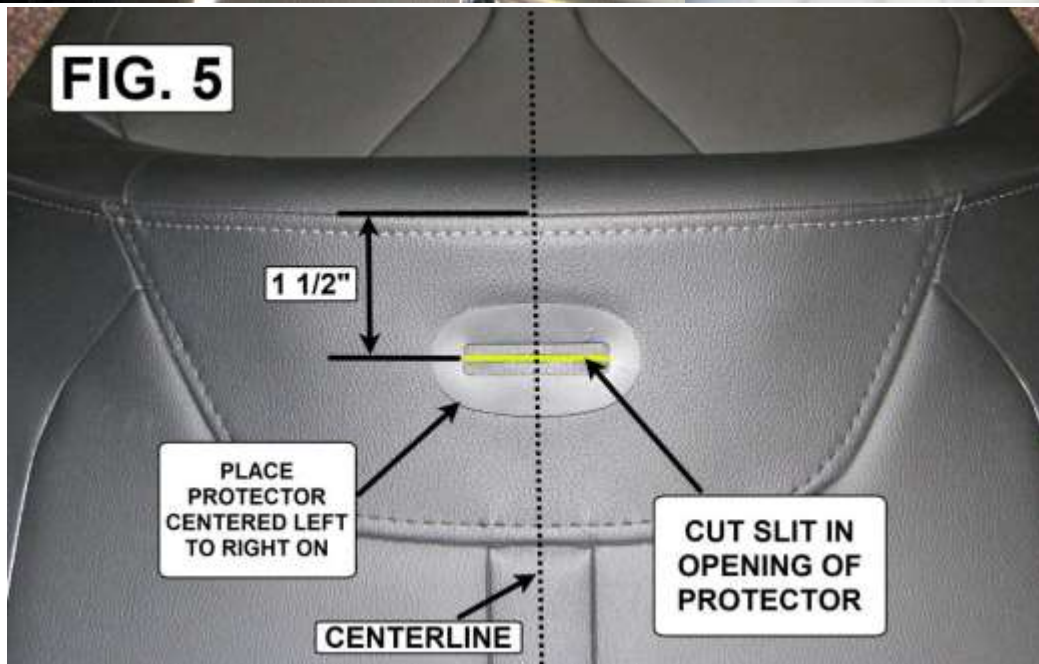
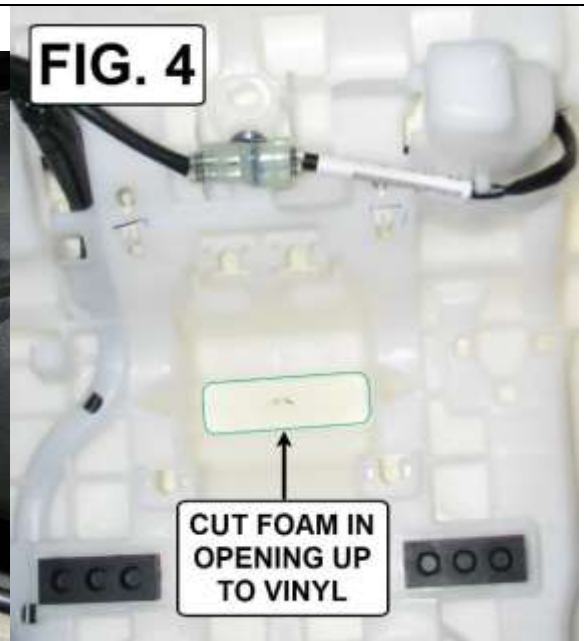
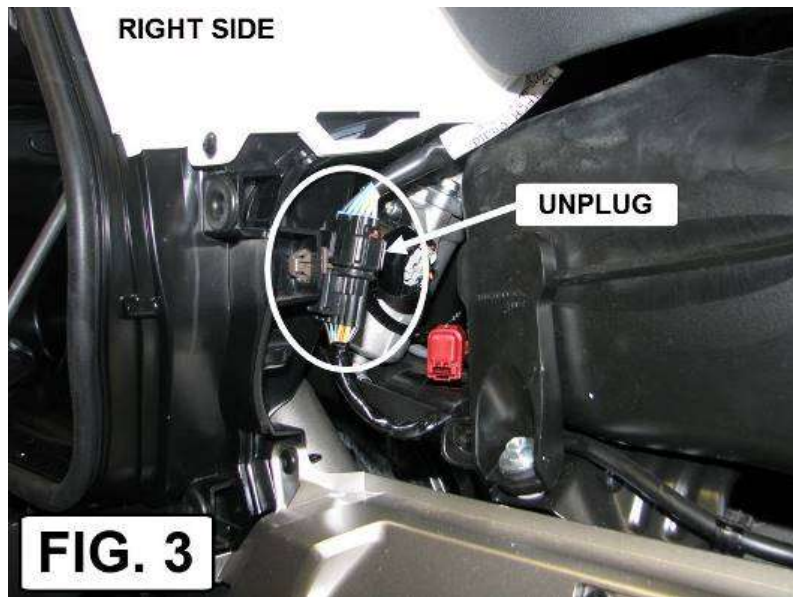

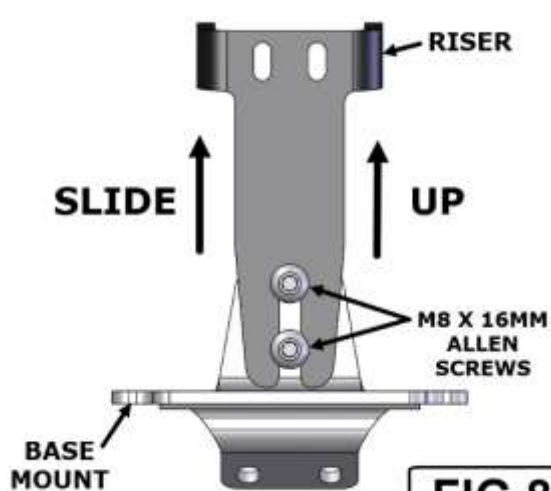

FIG. 8

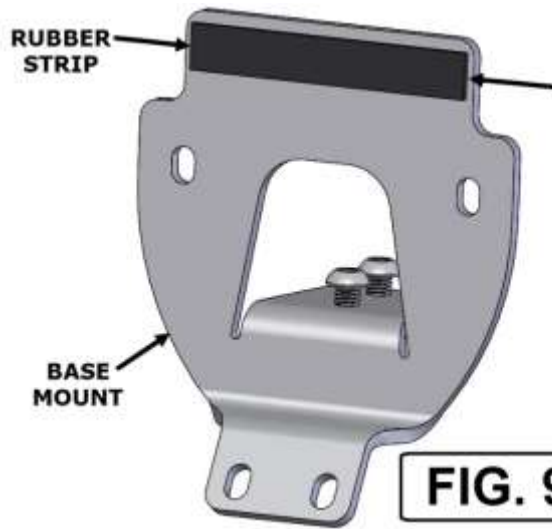

FIG. 9



FIG. 10

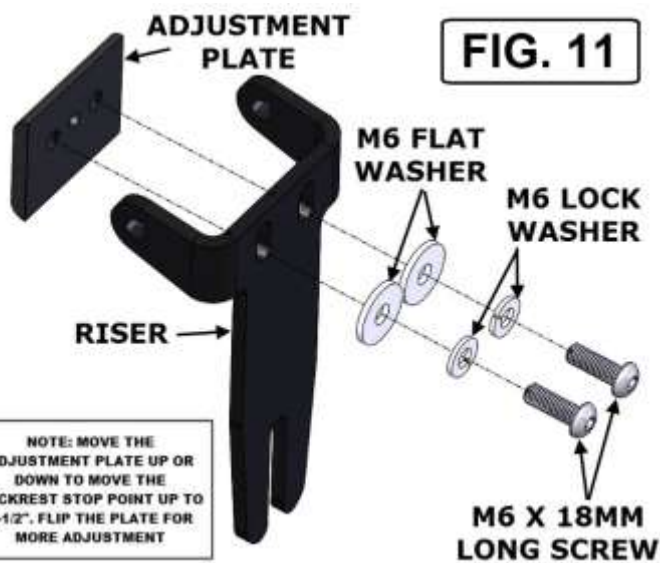

FIG. 11

NOTE: MOVE THE ADJUSTMENT PLATE UP OR DOWN TO MOVE THE BACKREST STOP POINT UP TO 1-1/2". FLIP THE PLATE FOR MORE ADJUSTMENT



FIG. 12