

PART NO. 52-920

SMART MOUNT BACKREST

FITMENT:

HONDA GOLDWING/GOLDWING TOUR 2018-NEWER

**TOOLS NEEDED:**

3MM ALLEN WRENCH

4MM ALLEN WRENCH

5MM ALLEN WRENCH

6MM ALLEN WRENCH

13MM WRENCH

7/16" (11MM) WRENCH

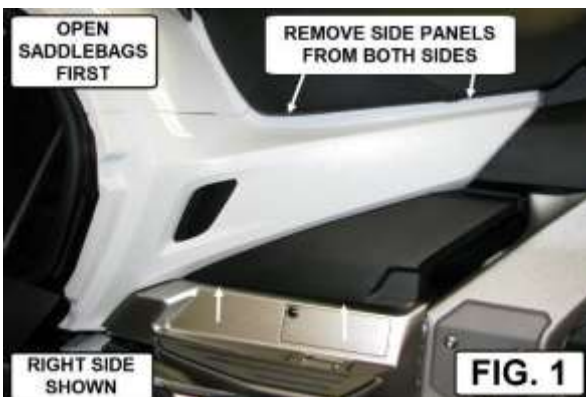
RUBBING ALCOHOL

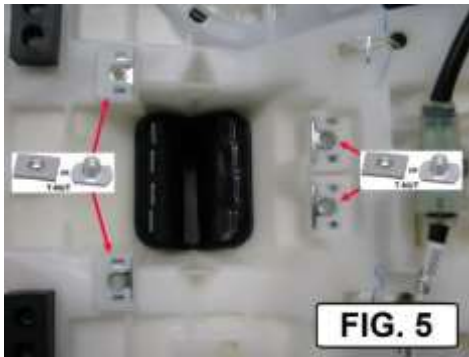
LINT FREE TOWEL

REMOVABLE THREAD LOCK

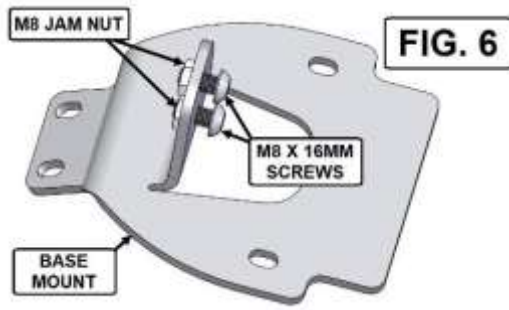
**PLEASE READ THROUGH AND UNDERSTAND THESE INSTRUCTIONS BEFORE BEGINNING.****\*USE REMOVABLE THREAD LOCK ON ALL FASTENERS\*****ESTIMATED INSTALLATION TIME: 30 TO 45 MIN.****INSTALLATION:**

1. OPEN BOTH SADDLEBAGS AND REMOVE BOTH SIDE PANELS. PULL ON THE FRONT OF EACH PANEL TO REMOVE THEM. SEE FIG. 1.
2. USING A 6MM ALLEN WRENCH REMOVE THE TWO ALLEN BOLTS HOLDING THE SEAT ON. THERE IS ONE ON EACH SIDE TOWARD THE FRONT OF THE SEAT. SEE FIG. 2.
3. UNPLUG THE CONNECTOR FOR THE SEAT ON THE RIGHT SIDE SHOWN IN FIG. 3.
4. LIFT THE FRONT OF THE SEAT UP AND PULL IT FORWARD TO REMOVE IT. PLACE THE SEAT WITH THE BOTTOM UP ON A CLEAN SURFACE.
5. REMOVE THE SEAT PLUG BY RELEASING IT FROM THE TAB SHOWN IN FIG. 4. PULL THE SEAT PLUG OUT FROM THE TOP OF THE SEAT.
6. INSERT THE FOUR T-NUTS INTO THE SLOTS IN THE BOTTOM OF THE SEAT AS SHOWN IN FIG. 5. IF NEEDED USE SOME SMALL PIECES OF TAPE TO HELP HOLD THE T-NUTS IN PLACE.
7. THREAD THE TWO M8 X 16MM LONG SCREWS INTO THE BASE MOUNT AS SHOWN IN FIG. 6. PUT THE TWO SUPPLIED JAM NUTS ON THE OPPOSITE SIDE AS SHOWN IN FIG. 6. DO NOT TIGHTEN YET.
8. PLACE THE SUPPLIED RISER ON THE TWO SCREWS AS SHOWN IN FIG. 7. USING A 5MM ALLEN WRENCH AND A 13MM WRENCH ADJUST AND TIGHTEN THE SCREWS AND JAM NUTS SO THAT THE HEAD OF THE SCREW IS AS CLOSE AS POSSIBLE TO THE RISER BUT THE RISER WILL STILL SLIDE OFF OF THE SCREWS.
9. REMOVE THE MASKING AND PLACE THE RUBBER STRIP SUPPLIED IN THE KIT ON THE BOTTOM SIDE OF THE BASE MOUNT AS SHOWN IN FIG. 8.
10. PLACE THE ASSEMBLED BASE MOUNT ON THE BOTTOM OF THE SEAT AS SHOWN IN FIG. 9. INSTALL THE FOUR M6 X 20MM LONG ALLEN SCREWS WITH THE FOUR FLAT WASHERS AS SHOWN IN FIG. 9. PUSH THE BASE MOUNT TOWARD THE FRONT OF THE SEAT AS YOU TIGHTEN THE SCREWS.
11. ASSEMBLE THE RISER AND THE ADJUSTMENT PLATE AS SHOWN IN FIG. 10. USE THE TWO M6 X 18MM LONG SCREWS WITH A FLAT WASHER AND LOCK WASHER ON EACH SCREW.
12. ASSEMBLE THE RISER TO THE REST OF THE UPPER BACKREST AS SHOWN IN FIG. 11.
13. SLIDE THE RISER THROUGH THE HOLE IN THE SEAT AND ONTO THE TWO SCREWS IN THE BASE MOUNT AS YOU DID IN STEP 8. ADJUST THE ADJUSTMENT PLATE AND THE TOP BRACKET TO YOUR DESIRED POSITION AND MAKE SURE ALL HARDWARE HAS BEEN TIGHTENED.
14. REMOVE THE UPPER BACKREST.
15. USING RUBBING ALCOHOL AND A LINT FREE TOWEL CLEAN THE AREA AROUND THE HOLE IN THE SEAT. LET DRY.
16. ATTACH THE TWO PIECES OF HOOK TO THE SEAT AS SHOWN IN FIG. 12. PRESS ON THE HOOK TO MAKE SURE THE ADHESIVE ADHERES TO THE SEAT.
17. PLACE THE BACKREST PLUG COVER ON THE SEAT AS SHOWN WITH THE HOLE TOWARD THE FRONT OF THE BIKE.
18. INSTALL THE UPPER BACKREST ASSEMBLY THROUGH THE BACKREST PLUG COVER. SNAP THE POUCH TO THE BACKREST PAD.

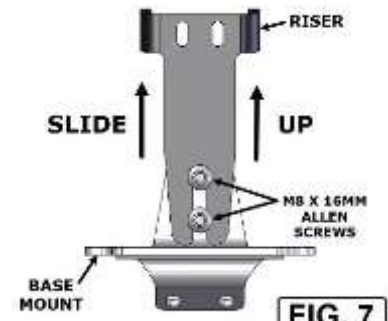




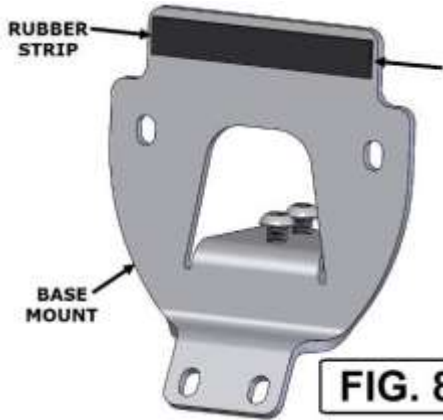
**FIG. 5**



**FIG. 6**



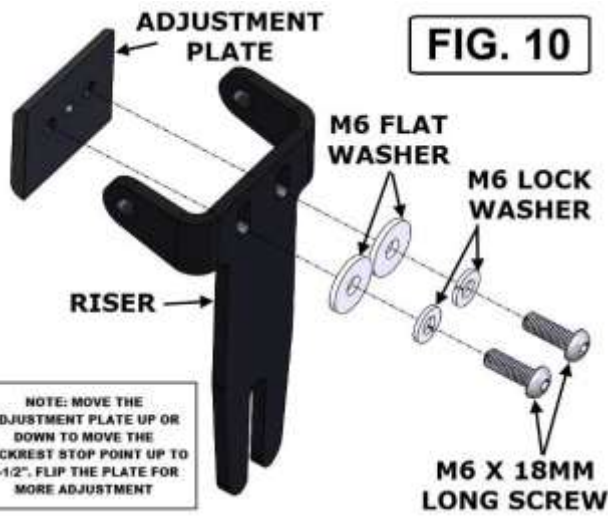
**FIG. 7**



**FIG. 8**



**FIG. 9**

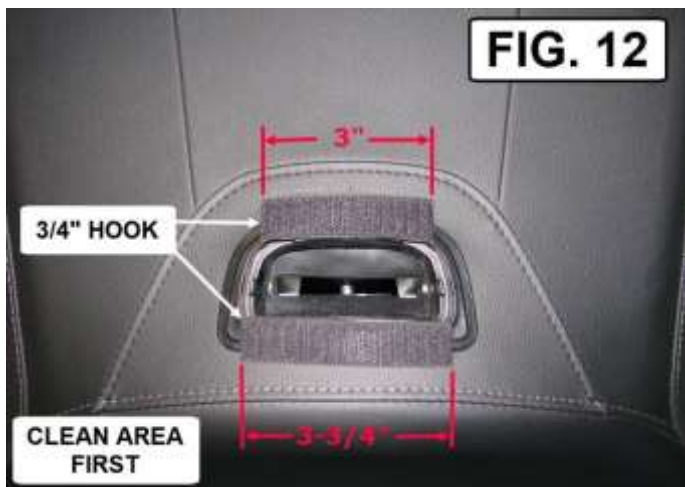


**FIG. 10**

NOTE: MOVE THE ADJUSTMENT PLATE UP OR DOWN TO MOVE THE BACKREST STOP POINT UP TO 1-1/2". FLIP THE PLATE FOR MORE ADJUSTMENT



**FIG. 11**



**FIG. 12**



**FIG. 13**