

BIG BIKE PARTS[®]

INSTALLATION INSTRUCTIONS

PART NO. 52-797A

REMOVABLE SMART MOUNT™ BACKREST

HONDA GL1800 GOLDWING 2001-NEWER

TOOLS NEEDED:	DRILL 9" SERRATED KNIFE MEASURING TAPE	9/32" DRILL BIT UTILITY KNIFE 7/16" WRENCH	6MM ALLEN WRENCH 5MM ALLEN WRENCH 4MM ALLEN WRENCH	1/8" ALLEN WRENCH 3/16" ALLEN WRENCH 13MM WRENCH	LINT-FREE CLOTH RUBBING ALCOHOL
HARDWARE INCLUDED:	BACKREST PAD BACKREST MOUNTING BRACKET ADJUSTING BRACKET ADJUSTABLE TONGUE PROTECTIVE COVER BOTTOM MOUNTING BRACKET	ADJUSTMENT PLATE RISER REMOVABLE MOUNT RUBBER STRIP M8 JAM NUT (2)	10-32 X 1/2" BUTTON HEAD CAP SCREW (2) 1/4-20 X 3" SOCKET HEAD CAP SCREW M6 X 14MM BUTTON HEAD CAP SCREW (2) M6 X 18MM BUTTON HEAD CAP SCREW (2) M6 X 25MM SOCKET HEAD CAP SCREW (2)	1/4-20 X 2-3/4" SOCKET HEAD CAP SCREW 1/4-20 NYLOCK NUT (2) M6 LOCK WASHER (6) M6 FLAT WASHER (2) M8 X 14MM BUTTON HEAD CAP SCREW (2)	

NOTE: THREAD LOCK COMPOUND SHOULD BE USED ON ALL HARDWARE.**PLEASE READ THROUGH AND UNDERSTAND THESE INSTRUCTIONS BEFORE BEGINNING.****ESTIMATED INSTALLATION TIME: 60 TO 90 MIN.**

1. Park motorcycle on level surface and place on center stand.
2. Using a 6mm Allen Wrench, remove the 4 bolts in the passenger handles (2 in each handle). **See Diagram 1.**
3. Once handles are removed, lift seat (on models equipped with heated seat, a wiring harness will need to be disconnected on underside of seat) to remove.
4. Turn seat upside-down on a work surface, place Bottom Mounting Bracket (Y-shaped) on underside of seat, nesting curve of Bottom Mounting Bracket along curve of seat bottom. Attach Rubber Strip to Bottom Mounting Bracket in line with factory installed rubber rests. **See Diagram 2.**
5. Using Bottom Mounting Bracket as a template, mark locations of holes on seat base. **See Diagram 2.**
6. Remove Bottom Mounting Bracket to drill holes. Using a 9/32" bit, drill holes through white plastic seat base according to marked locations from step 5. **On models equipped with heated seat, care should be taken to avoid damaging seat warmer wires when drilling.**
7. After drilling holes, flip seat right-side up. Clean the upper driver's seat-back area with rubbing alcohol and a lint free cloth. **See Diagram 3.**
8. Locate centerline of seat (centerline should match up with the centerline stitching on the driver and passenger cushions). **See Diagram 3.**
9. Mark a location on seat-back top surface approximately 1-1/4" back from front seams along centerline of seat. **See Diagram 3.**
10. Align Protective Cover (Rubber gasket) and remove backing from double-sided tape to affix to seat at marked location. **See Diagram 3.**
11. With Protective Cover secured, use a utility knife to make a 1-1/2" wide slit in the vinyl seat covering. **See Diagram 3.**
Before proceeding, become familiar with steps 13-17 and accompanying Diagrams.
12. Using a long, serrated knife (a bread knife works well), cut down through the slit, gently cutting through the foam. Angle of the cut should be approximately square to the driver's seat pad. The knife cut will create a guided path for the Top Mounting Bracket. **See Diagram 4. On models equipped with heated seat, care should be taken to avoid damaging the seat warmer wires when cutting, sharp edge of blade should face left, away from the wires.**
13. Push the knife down until it appears on the other side of the drilled holes in the seat base. Remove knife from seat.
14. Using a 4mm Allen Wrench, install the Adjustment Plate to Removable Mount using (2) M6-1 x 18mm Button Head Cap Screw and (2) 6mm Lock Washers and (2) 6mm Flat Washers. Hand tighten. **See Diagram 5.**
15. Attach the Removable Mount to the Riser using the two M8 x 14mm screws as shown in diagram 6. Screw the screws in far enough so that the Removable Mount and the Riser are snug but you can still slide them apart. Install the M8 jam nuts on the back side to hold the screws from turning.
16. Push Riser down through the knife cut and guide through the path in seat foam until the M6 x 1.0 threaded holes in the Riser align with the drilled holes in seat bottom.
17. Place Bottom Mounting Bracket in same location as in step 4, aligning holes in the seat bottom with the tapped holes at the end of Riser. Using a 5mm Allen Wrench, attach the Bottom Mounting Bracket to Top Mounting Bracket through seat bottom by installing (2) M6-1.0 x 25mm Socket Head Cap Screws with (2) M6 Lock Washers.
18. Using a 1/8" Allen Wrench, attach Backrest Mounting Bracket to Backrest Pad by installing (2) 10-32 x 1/2" Button Head Cap Screws into the (2) punched holes in rear of Backrest Pad (slight pressure may be required to start screws in Backrest Pad). Tighten screws.
19. Using a 3/16" Allen Wrench and a 7/16" wrench, install the Adjustable Tongue to the Top Mounting Bracket with the Big Bike Parts stamp facing forward using (1) 1/4-20 x 3" Socket Head Cap Screw and (1) 1/4-20 Nylock Lock Nut. Hand tighten to retain adjustability.
20. Using a 3/16" Allen Wrench and a 7/16" wrench, install Adjusting Bracket to Backrest Mounting Bracket on Backrest Pad with Big Bike Parts stamp facing rear of bike using (1) 1/4-20 x 2-3/4" Socket Head Cap Screw and (1) 1/4-20 Nylock Lock Nut. Hand tighten to retain adjustability.
21. Using a 4mm Allen wrench, attach adjustable tongue to adjusting bracket at desirable height using (2) M6-1.0 x 14mm Button Head Cap Screw and (2) 6mm Lock Washers. Tighten. **Review Diagram 6.**
22. To complete backrest installation, reinstall seat by reversing steps 2 and 3.
23. Move adjustment bracket to desired position and tighten all fasteners.

Diagram 1

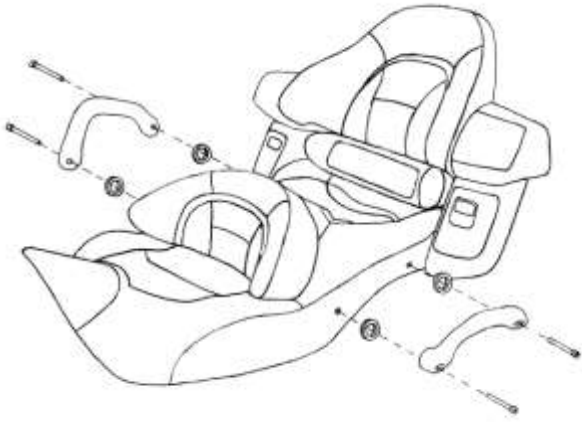

Diagram 2

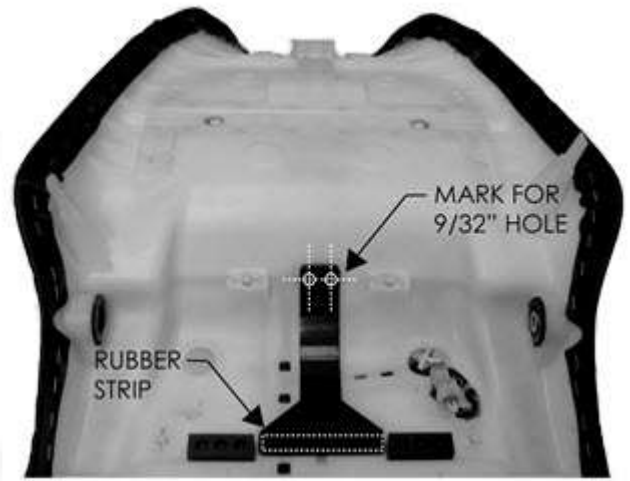

Diagram 3

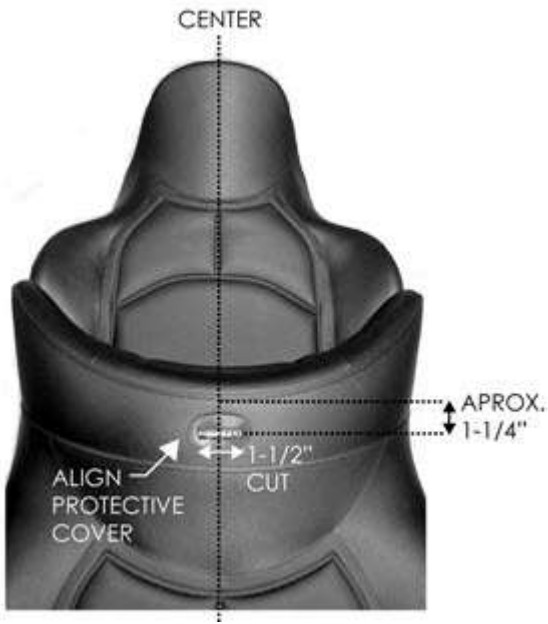

Diagram 4

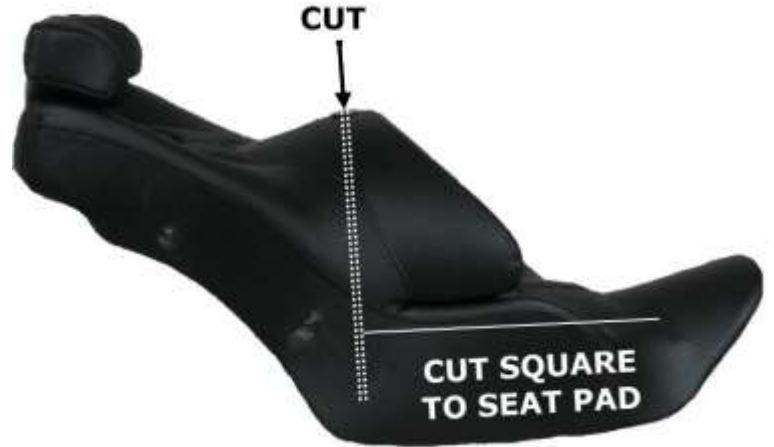

Diagram 5

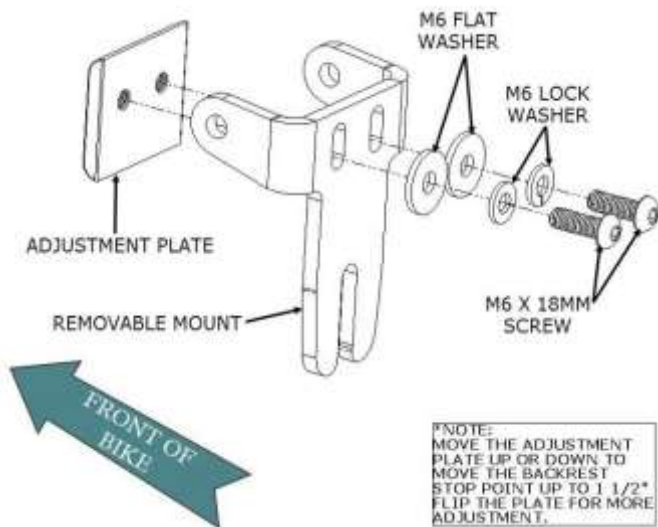

Diagram 6

