

TOOLS NEEDED:	8MM WRENCH	7/32" (5.5MM) DRILL BIT	DRILL	TAPE MEASURE	MASKING TAPE
	RUBBING ALCOHOL	LINT FREE TOWEL	MARKER	90 DEGREE PHILLIPS SCREWDRIVER	
PARTS LIST:	MUD GUARD (1X)	CHROME ACCENT (1X)	M5 X 16MM SCREW (2X)	M4 X 10MM SCREWS (3X)	
	M5 FLAT WASHER (2X)	M5 LOCK NUT (2X)	SHOW CAP BASE (2X)	SHOW CAP (2X)	

PLEASE READ THROUGH AND UNDERSTAND THESE INSTRUCTIONS BEFORE BEGINNING.

**INSTALLATION:**

1. SET PARKING BRAKE ON THE SPYDER RT AND REMOVE THE KEY FROM THE IGNITION.
2. USING A LINT FREE TOWEL AND RUBBING ALCOHOL CLEAN THE TOP OF THE LOWER TAB ON THE REAR FENDER. SEE FIG. 1.
3. ALSO CLEAN THE INSIDE OF THE REAR FENDER IN THE AREA SHOWN IN FIG. 1 AND LET BOTH AREAS DRY.
4. REMOVE THE THREE M4 X 10MM SCREWS HOLDING THE BLACK MUD GUARD AND THE CHROME ACCENT TOGETHER.
5. REMOVE THE MASKING FROM THE DOUBLE-SIDED TAPE ON THE CHROME ACCENT. SEE FIG. 2.
6. PLACE THE CHROME ACCENT ON THE REAR AS SHOWN IN FIG. 3.
7. PUT PRESSURE ON THE AREA WITH THE DOUBLE-SIDED TAPE TO LOCK IT INTO POSITION.
8. TAKE THE MUD GUARD AND REMOVE THE MASKING ON THE DOUBLE-SIDED TAPE.
9. USING THE TWO PINS ON THE CHROME ACCENT TO ALIGN IT PLACE THE MUD GUARD INTO POSITION ON THE INSIDE OF THE REAR FENDER.
10. REINSTALL THE THREE M4 X 10MM SCREWS USING A 90 DEGREE PHILLIPS SCREWDRIVER. SEE FIG. 2. BE CAREFUL NOT TO OVER TIGHTEN.
11. PUSH LIGHTLY ON THE BOTTOM OF THE MUD GUARD WITH ONE HAND AND SQUEEZE THE TOP TOGETHER TO ATTACH THE TAPE TO THE INSIDE OF THE REAR FENDER. THEN USE BOTH HAND AND PRESS THE MUD GUARD AND FENDER TOGETHER TO SET THE TAPE.
12. TAKE TWO PIECES OF MASKING TAPE AND PLACE THEM ON THE REAR FENDER AS SHOWN IN FIG. 3.
13. FIND THE CENTER OF THE FENDER AND MEASURE OUT 3 INCHES EACH WAY (6" TOTAL) AND MARK A LINE ON THE TAPE. SEE FIG. 3.
14. MEASURE UP 1-1/4 INCHES FROM THE TOP OF THE CHROME ACCENT AS SHOWN IN FIG. 3 AND DRAW A LINE.
15. USING A 7/32" DRILL BIT DRILL THROUGH THE REAR FENDER AND THE MUD GUARD AT THE TWO POINTS YOU MARKED. REMOVE MASKING TAPE.
16. TAKE ONE OF THE M5 X 16MM SCREWS AND THREAD IT THROUGH ONE OF THE SHOW CAP BASES. SEE FIG. 4.
17. INSERT THE SCREW THROUGH ONE OF THE HOLES YOU DRILLED AND INSTALL A FLAT WASHER AND NUT ON THE BACK.
18. REPEAT STEPS 16 AND 17 FOR THE OTHER HOLE AND TIGHT BOTH SCREWS.
19. INSTALL THE TWO SHOW CAPS ON EACH SCREW AS SHOWN IN FIG. 4.
20. LET TAPE CURE FOR 24 HOURS BEFORE USING SPYDER.

**FIG. 1**

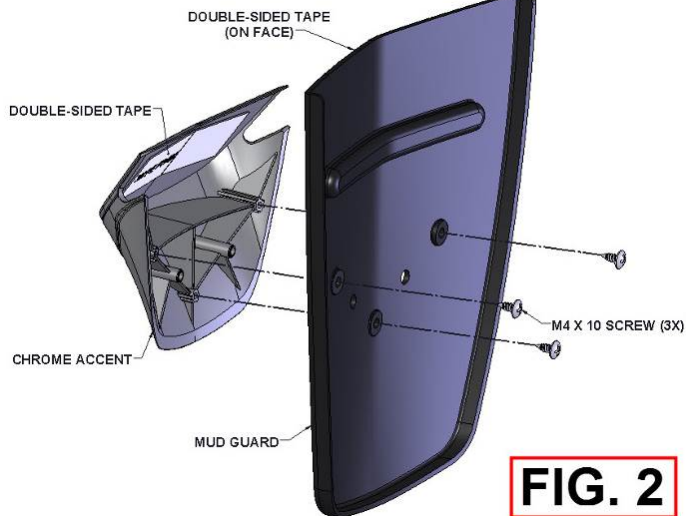
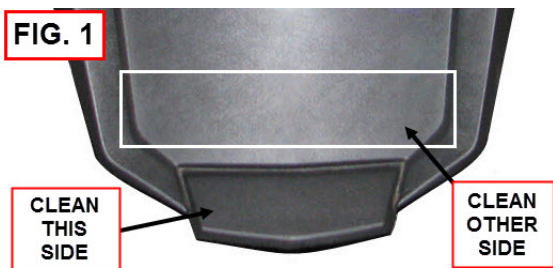

**FIG. 2**

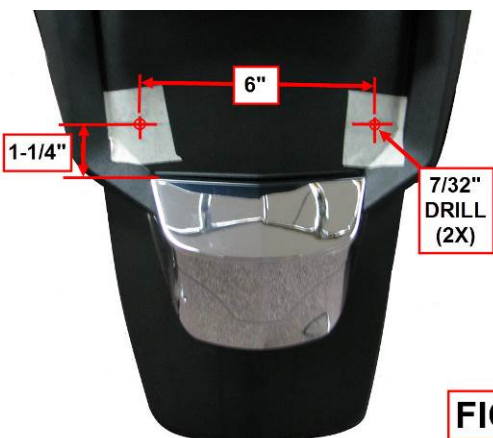

**FIG. 3**

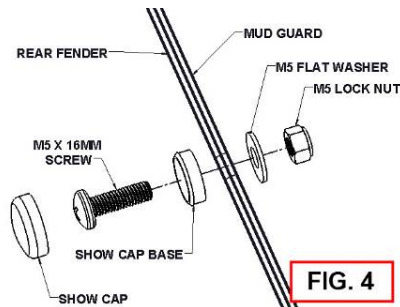

**FIG. 4**