

TOOLS NEEDED:	10MM WRENCH 4MM ALLEN WRENCH 6MM ALLEN WRENCH	13MM SOCKET WRENCH 3MM ALLEN WRENCH	T27 TORX DRIVER PHILLIPS SCREW DRIVER	5MM ALLEN WRENCH 10MM SOCKET WRENCH	SMALL FLAT SCREWDRIVER 2MM ALLEN WRENCH
HARDWARE INCLUDED:	M8-1.25 X 40MM LONG BUTTON HEAD CAP SCREW (2X) M6-1.0 X 16MM LONG BUTTON HEAD CAP SCREW (2X) M5-0.8 X 14MM LONG BUTTON HEAD CAP SCREW (8X) 30MM X 54MM RUBBER PAD (2X)		1/4-20 X 3/4" LONG PHILLIPS PAN HEAD SCREW (4X) M8 FLAT WASHER (2X) 1/4" FLAT WASHER (4X) CHROME SCREW CAP (2X)		

**NOTE: THREAD LOCK COMPOUND SHOULD BE USED ON ALL HARDWARE****PLEASE READ THROUGH AND UNDERSTAND THESE INSTRUCTIONS BEFORE BEGINNING.**

1. PLACE THE SPYDER RT ON A LEVEL SURFACE AND SET THE PARKING BRAKE.
2. OPEN THE SEAT AND UNPLUG THE SEAT HEATER IF EQUIPPED.
3. USING A SMALL FLAT SCREWDRIVER RELEASE THE CLIPS ON BOTH ENDS OF THE GAS SHOCK AND REMOVE THE SHOCK. SEE DIAGRAM 1.
4. CLOSE THE SEAT AND USING A 10MM WRENCH REMOVE THE 2 HINGE BOLTS FROM THE BACK OF THE SEAT. BE CAREFUL NOT TO LET THE SQUARE NUTS FALL INTO THE OPENINGS UNDER THE SEAT.
5. LIFT SEAT OFF AND SET ASIDE.
6. USING A 13MM SOCKET WRENCH REMOVE THE TWO REAR FLANGE BOLTS SHOWN IN DIAGRAM 2. THESE BOLTS WILL NOT BE REUSED.
7. USING A T27 TORX DRIVER REMOVE THE TWO BUTTON HEAD SCREWS SHOWN IN DIAGRAM 2. THESE SCREWS WILL NOT BE REUSED.
8. USING A 10MM WRENCH AND A 10MM SOCKET REMOVE THE M6 X 130MM BOLT SHOWN IN DIAGRAM 2. THIS BOLT WILL BE REUSED.
9. REFERENCING DIAGRAM 3 DETERMINE WHICH ARM ASSEMBLY IS THE RIGHT AND WHICH IS THE LEFT.
10. ATTACH THE RIGHT SIDE ARM ASSEMBLY TO THE RIGHT SIDE BASE PLATE USING FOUR M5 X 14MM LONG BUTTON HEAD SCREW AND TIGHTEN WITH A 3MM ALLEN WRENCH. SEE DIAGRAM 4.
11. PEEL THE PVC BACKING FROM ONE OF THE BLACK RUBBER PADS AND ATTACH IT TO THE BOTTOM OF THE BASE PLATE. PLACE IT SO THAT THE NOTCHES FIT AROUND ALL OF THE SCREWS YOU JUST INSTALLED. SEE DIAGRAM 4.
12. REPEAT STEP 10 AND 11 TO ASSEMBLE THE LEFT SIDE ARM ASSEMBLY.
13. SET THE RIGHT AND LEFT SIDE ASSEMBLIES IN PLACE AS SHOWN IN DIAGRAM 5. INSTALL THE M6 X130MM BOLT FROM THE RIGHT SIDE, THROUGH THE SLOT ON THE RIGHT BASE PLATE AND THROUGH THE SLOT IN THE LEFT BASE PLATE. START THE NUT BUT DO NOT TIGHTEN.
14. START BUT DON'T TIGHTEN THE M8 WASHER AND M8 X 40MM SCREW AS SHOWN IN DIAGRAM 6 ON BOTH OF THE BASE PLATES.
15. USING A 4MM ALLEN WRENCH INSTALL THE TWO M6 X 16MM SCREW IN THE BASE PLATES AND TIGHTEN. SEE DIAGRAM 6.
16. USING A 10MM WRENCH AND A 10MM SOCKET WRENCH TIGHTEN THE M6 X 130MM BOLT.
17. USING A 5MM ALLEN WRENCH TIGHTEN THE TWO M8 X 40 SCREW.
18. REINSTALL THE SEAT IN THE REVERSE ORDER YOU REMOVED IT.
19. USE A PHILLIPS SCREWDRIVER TO INSTALL THE ARMREST PADS TO THE ARMRESTS. USE TWO 1/4" FLAT WASHERS AND TWO 1/4-20 X 3/4" SCREWS ON EACH PAD.
20. TO ADJUST THE RESISTANCE OF THE PIVOT OF THE ARMRESTS, LOOSEN THE TWO SET SCREWS ON EACH SIDE OF THE CHROME BASE WITH A 2MM ALLEN WRENCH. THEN USE A 6MM ALLEN WRENCH AND TIGHTEN OR LOOSEN THE BOLT IN THE TOP OF THE CHROME MOUNT. TIGHTEN SET SCREW BEFORE MOVING ARM.
21. INSTALL THE TWO CHROME BOLT CAPS IN THE 6MM HEX ON TOP OF THE ADJUSTMENT BOLT.

Diagram 1

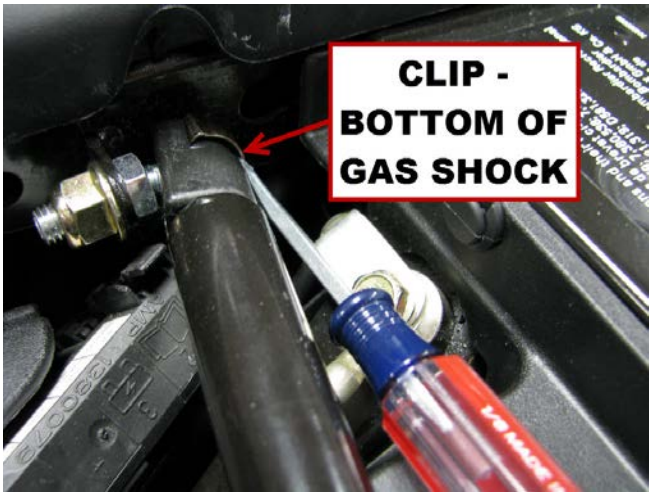

Diagram 2

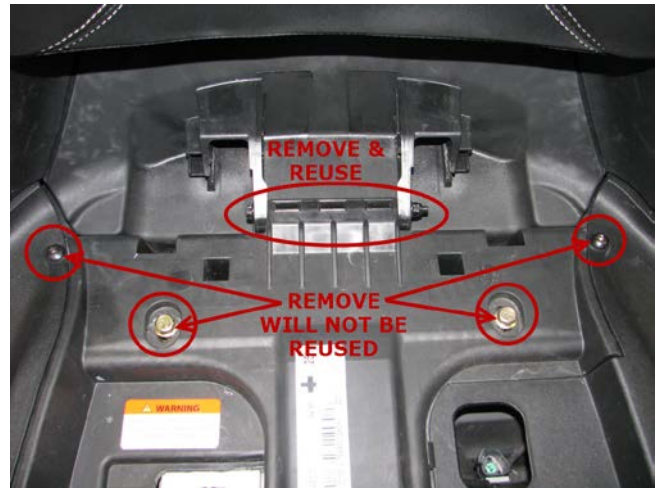

Diagram 3

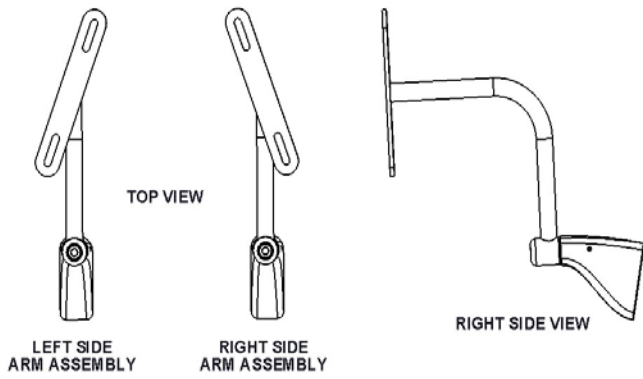

Diagram 4

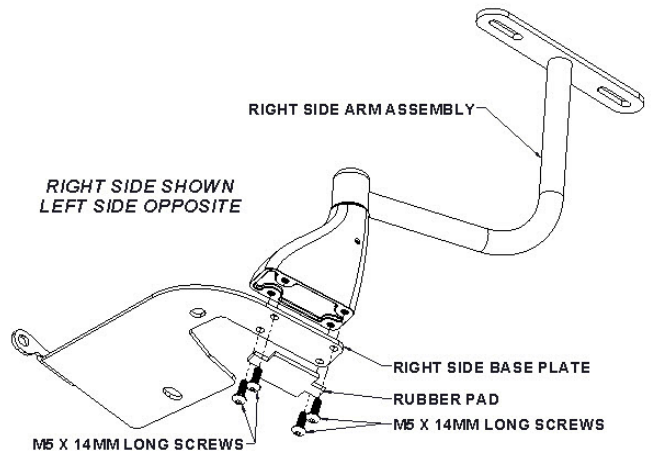

Diagram 5

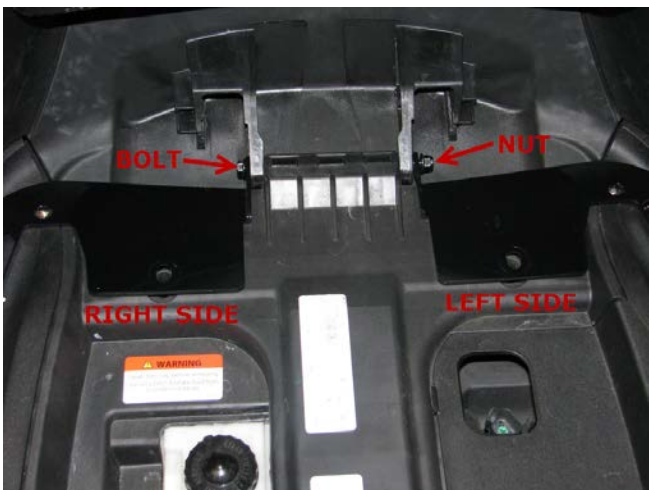

Diagram 6

