

PART NO. 21-557

CHROME SHIFTER PEG

FITMENT: VICTORY AND INDIAN WITH M8-1.25 SHIFTER PEG

TOOLS NEEDED: LOCKING PLIERS

2MM ALLEN WRENCH

6MM ALLEN WRENCH

THREAD LOCK COMPOUND

RUBBING ALCOHOL

**PLEASE READ THROUGH AND UNDERSTAND THESE INSTRUCTIONS BEFORE BEGINNING. USE REMOVABLE THREAD LOCK ON ALL FASTENERS.****ESTIMATED INSTALLATION TIME: 10 TO 15 MIN.****INSTALLATION:**

1. PLACE BIKE ON A FLAT SURFACE AND BLOCK THE REAR TIRE TO KEEP THE BIKE FROM BEING ABLE TO ROLL.
2. USING A LOCKING PLIERS REMOVE THE OEM SHIFTER PEG BY ROTATING IT COUNTER-CLOCKWISE.
3. REMOVE ANY THREAD LOCK FROM THE THREADS IN BIKE'S SHIFT LEVER USING RUBBING ALCOHOL. LET DRY.
4. ATTACH THE MOUNT TO THE BIKE AS SHOWN IN **FIG. 1**. USE REMOVABLE THREAD LOCK ON THE M8 X 55MM ALLEN BOLT.
5. THERE ARE THREE SETS OF M4 SET SCREWS THAT COME IN THE KIT. YOU NEED TO USE THE 6MM LONG SET SCREWS. THE OTHERS WILL NOT BE USED.
6. SLIDE THE SHIFTER COVER OVER THE MOUNT AND INSTALL THE TWO M4 X 6MM LONG SET SCREWS AS SHOWN IN **FIG. 2**. BE SURE TO USE REMOVABLE THREAD LOCK ON THE SET SCREWS.
7. ROTATE THE SHIFTER COVER TO YOUR DESIRED POSITION AND TIGHTEN BOTH SET SCREWS.
8. AFTER YOUR FIRST RIDE CHECK TO MAKE SURE ALL FASTENERS ARE STILL TIGHT.

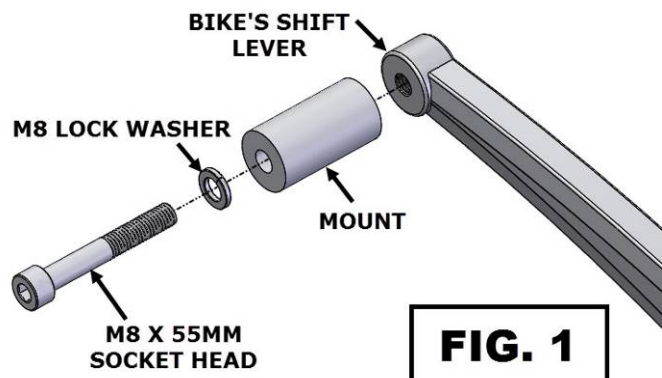
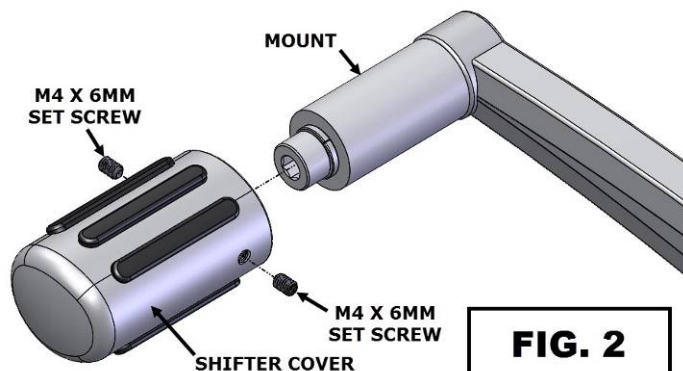
**FIG. 1****FIG. 2**