

BIG BIKE PARTS® INSTALLATION INSTRUCTIONS

PART NO. 21-421 J,L,P,Q,R DRIVER & PASSENGER PEG KIT

TOOLS NEEDED: 2 PLIERS, 6MM ALLEN WRENCH, 2.5MM ALLEN WRENCH, RULER, FILE, THREADLOCKER, NEEDLE NOSE PLIERS, 3/16 ALLEN WRENCH, 3MM ALLEN WRENCH, 10MM WRENCH

NOTE: WE RECOMMEND USING A SMALL AMOUNT OF THREADLOCKER ON ALL THREADED HARDWARE INSTALLED.

1. REMOVE THE OEM PEG FROM THE PASSENGER MOUNTING BRACKET, BY REMOVING THE COTTER PIN OR E-CLIP AND THE OEM PEG PIN (A) WITH NEEDLE NOSE PLIERS.
2. MEASURE THE DISTANCE FROM THE PINHOLE TO THE BACK OF THE PASSENGER MOUNTING BRACKET. THEN TRANSFER THE DISTANCE ONTO THE DETENT PLATE (L). IF THE DISTANCE IS SHORTER THAN A SCRIBED LINE, BREAK THE DETENT PLATE (L) BY HOLDING THE DETENT PLATE (L) ON EACH SIDE OF THE NEXT SCRIBE LINE AND BENDING 90 DEGREES. SEE FIGURE 1.
3. USING A FILE FINE TUNE THE DETENT PLATE (L) BY FILING DOWN THE FLAT END OF THE DETENT PLATE (L) UNTIL THE HOLE IN THE DETENT PLATE (L) ALIGNS WITH THE HOLE IN THE MOUNTING BRACKET AND THE FLAT END OF THE DETENT PLATE (L) IS FLAT AGAINST THE BACK OF THE MOUNTING BRACKET.
4. SLIDE THE UNIVERSAL PASSENGER STEM (H) INTO THE PASSENGER-MOUNTING BRACKET AND REINSERT THE OEM PIN (A). THEN MEASURE THE DISTANCE BETWEEN THE BACK OF THE UNIVERSAL PASSENGER STEM AND THE BACK OF THE PASSENGER MOUNTING BRACKET WHEN THE TOP OF THE UNIVERSAL PASSENGER STEM (H) AND THE PASSENGER MOUNTING BRACKET ARE PARALLEL.
5. IF THERE IS A GAP BETWEEN THE BACK OF THE UNIVERSAL PASSENGER STEM (H) AND THE PASSENGER MOUNTING BRACKET PULL THE UNIVERSAL PASSENGER STEM (H) OUT OF THE PASSENGER MOUNTING BRACKET AND, USING A 2.5MM ALLEN WRENCH, INSTALL THE TWO SET SCREWS (M) INTO THE TWO HOLES IN THE BACK OF THE UNIVERSAL PASSENGER STEM (H). ADJUST THEM SO THE SCREWS STICK OUT THE NOTED DISTANCE FROM STEP 4. IF THE ANGLE OF THE UNIVERSAL PASSENGER STEM (H) IS NOT TO YOUR PREFERENCE REMOVE THE PEG PIN AND ADJUST THE SET SCREWS (M) ACCORDINGLY. MAKE SURE THAT BOTH SET SCREWS STICK OUT THE SAME DISTANCE.
6. SLIDE THE SPRING (N) AND BALL (O) INTO THE SMALL HOLE IN THE UNIVERSAL PASSENGER STEM (H) AND PLACE THE DETENT PLATE (L) OVER THE BALL WITH THE FLAT END OF THE DETENT PLATE (L) PARALLEL WITH THE BACK OF THE UNIVERSAL PASSENGER STEM (H). IF THE PIN REMOVED IN STEP 1 WAS 6MM IN DIAMETER INSERT THE BUSHING (F) INTO THE PINHOLE IN THE PASSENGER STEM (A) AND IF THE PIN WAS 8MM DISREGARD THE BUSHING (F). ALSO, IF THE PASSENGER MOUNTING BRACKET IS WIDER THAN THE UNIVERSAL PASSENGER STEM (H) USE WASHERS (G), ON THE OPPOSITE SIDE AS THE DETENT PLATE (L), TO SHIM UNTIL TIGHT.
7. THEN INSERT THE UNIVERSAL PASSENGER STEM (H) INTO THE PASSENGER MOUNTING BRACKET AND REINSERT THE OEM PEG PIN (A). SEE FIGURE 2.
8. SLIDE THE NEW PEG (E) OVER THE UNIVERSAL PASSENGER STEM, ROTATE PEG (E) TO DESIRED LOCATION, THEN INSERT THE 5/16-18 SOCKET HEAD CAP SCREW (K) AND TIGHTEN.
9. REPEAT STEPS FOR OTHER SIDE.

FIG. 1

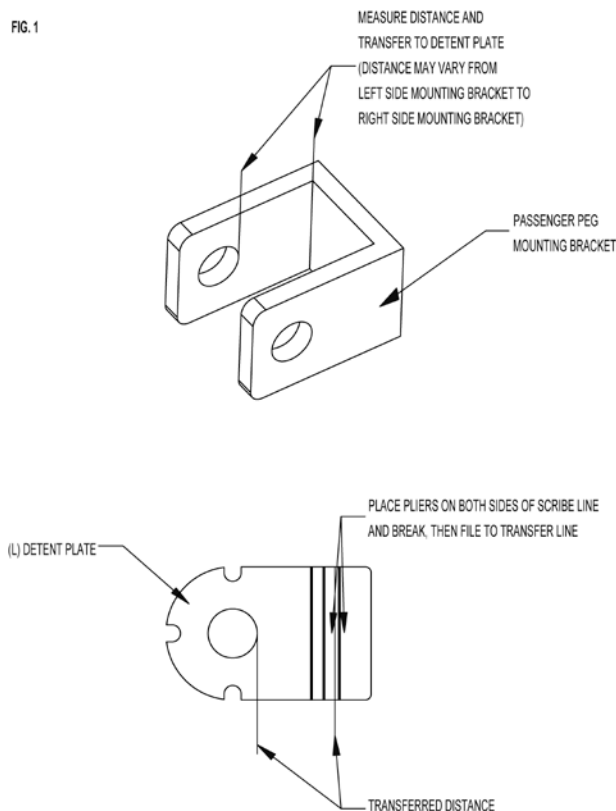

FIG. 2

