

Copyright © 2021 by Big Bike Parts, Inc. No part of this instruction sheet may be reproduced without the written permission of Big Bike Parts, Inc.

PART NO. 20-402, 20-402C, 20-402CT, 20-402TT

WINDSHIELD

FITMENT: CAN-AM RYKER 2019-NEWER

TOOLS NEEDED: 10MM WRENCH

4MM ALLEN WRENCH

3MM ALLEN WRENCH

REMOVABLE THREAD LOCK

PLEASE READ THROUGH AND UNDERSTAND THESE INSTRUCTIONS BEFORE BEGINNING. USE REMOVABLE THREAD LOCK ON ALL FASTENERS.

(NOTE: HARDWARE IN FIGURES SHOWN AS CHROME FOR VISIBILITY PURPOSES, ACTUAL HARDWARE IS BLACK EXCEPT THE ACORN NUTS.)

ESTIMATED INSTALLATION TIME: 15 TO 20 MIN.

INSTALLATION:

1. STARTING ON THE LEFT SIDE, INSTALL TWO M6 X 30MM STUDS IN THE CLUSTER SUPPORT (FIG. 1).
2. INSTALL TWO M6 FLANGE NUTS ON THE TWO STUDS AND TIGHTEN AGAINST THE CLUSTER SUPPORT WHILE HOLDING THE STUD WITH A 3MM ALLEN WRENCH (FIG. 1). *NOTE: FLANGE IS ON THE OUTSIDE AWAY FROM THE CLUSTER SUPPORT.*
3. INSTALL A NYLON SPACER ON THE LOWER STUD AGAINST THE FLANGE NUT (FIG. 1).
4. USE FIG. 2 TO DETERMINE THE LEFT AND RIGHT SIDE WINDSHIELD MOUNTS AND SET THE RIGHT SIDE MOUNT ASIDE FOR NOW.
5. USING A 10MM WRENCH, INSTALL THE LEFT SIDE WINDSHIELD MOUNT ACCORDING TO FIG. 3.
6. REPEAT STEPS 1 THROUGH 5 ON THE RIGHT SIDE.
7. INSTALL THE WINDSHIELD USING THE FOUR M6 X 15MM SCREWS AND FOUR M6 FENDER WASHERS AS WELL AS FOUR M6 ACORN NUTS ON THE BACK SIDE (FIG. 4). **(DO NOT OVERTIGHTEN SCREWS OR GET REMOVABLE THREAD LOCK ON THE WINDSHIELD OTHERWISE THE WINDSHIELD WILL BREAK)**

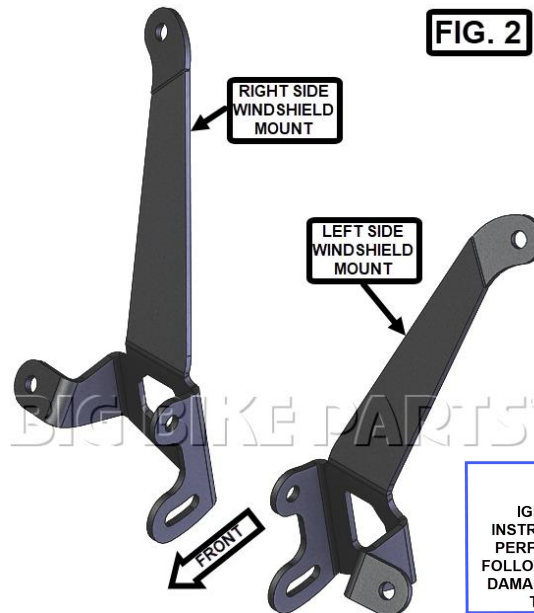
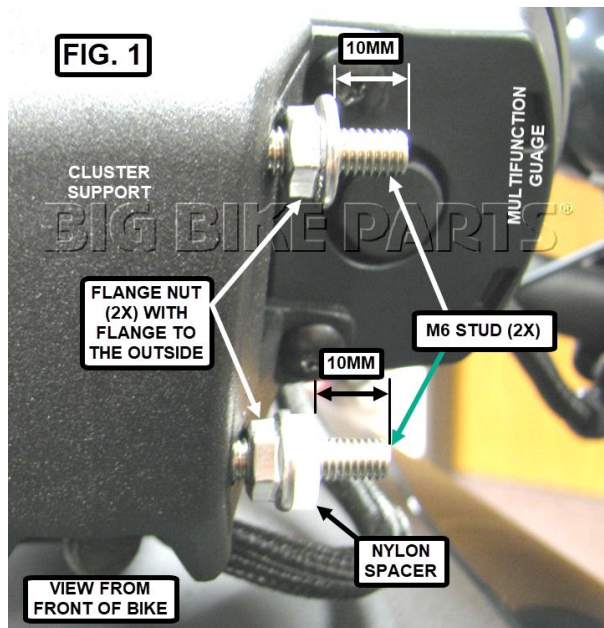
**NOTICE**

IGNORING THE CONTENTS OF THESE INSTRUCTIONS MAY AFFECT THE PRODUCT PERFORMANCE AND FUNCTIONALITY. NOT FOLLOWING THESE INSTRUCTIONS MAY CAUSE DAMAGE TO THE PRODUCT OR THE VEHICLE TO WHICH IT IS BEING ATTACHED.

