



### **Instructions for use**

Thank you for purchasing your new SHOEI helmet. This manual contains valuable information to help you understand how to operate and maintain your helmet. Please read this manual carefully before use and keep it for future reference. Your SHOEI dealer can provide a replacement if this manual is lost.

***X-fourteen***  
***X-Spirit III***

## **English**

Read This First	3
Confirm the Packed Items	4
Parts Description	5
Breath Guard	6
Applying Silicone Oil	6
Lower Air Spoiler & Chin Curtai	7
CWR-F Tear-off Button	8
CWR-F Shield / Visor	- 10
Important Notice about Handlin the CWR-F Shield / Visor	11
PINLOCK® EVO lens	12
Replacing Interior Parts	13
Removing Interior Parts	- 15
Ear Pads	15
Center Pad	- 18
Adjustment of Equipping position of Interiors	19
Installing Interior Parts	- 21
Important Notice about Handling Interior Parts	22
E.Q.R.S. (Emergency Quick Release System)	23
WARNING	24
Parts List	25

## Read This First

**This product is a motorcycle helmet.**

Do not use it for any purposes other than riding a motorcycle. If you use the helmet for any other purpose, it may not provide sufficient protection in case of an accident.

**No helmet can protect the wearer against all foreseeable high speed and low speed impacts.**

For maximum head protection, the helmet must fit properly and the retention system must be securely fastened under the chin. The helmet should allow sufficient peripheral vision when secure on your head. If your helmet is too large, it may slip or move on your head while riding. This could cause your helmet to come off in an accident or obstruct your vision while riding resulting in personal injury or death. To learn to properly wear and secure your helmet, see the booklet "How to Use Your Helmet Properly" that is packed with your helmet.

The contents of this manual are subject to change without notice.

The illustrations in this manual may differ from the actual product.

The copyrights for this manual belong to SHOEI CO., LTD. Reproduction or copying of this manual without written permission is strictly prohibited.

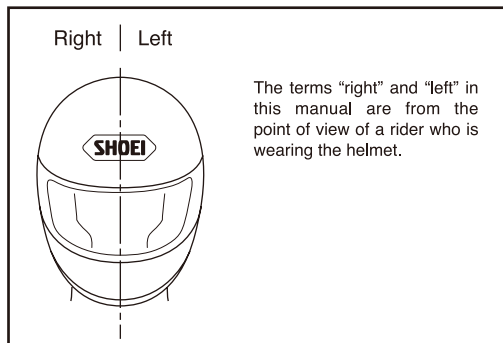

## Confirm the Packed Items

After opening the product box, please confirm that all parts and accessories are included.

1. Helmet
2. PINLOCK® EVO lens for CWR-F(DKS303)
3. Breath Guard
4. Chin Curtain
5. Lower Air Spoiler
6. Helmet Bag
7. Instruction Manual
8. "How to use your helmet properly"
9. Warning label (E-3 tag: for ECE R22 Products)
10. SHOEI logo stickers (2)
11. Silicone Oil

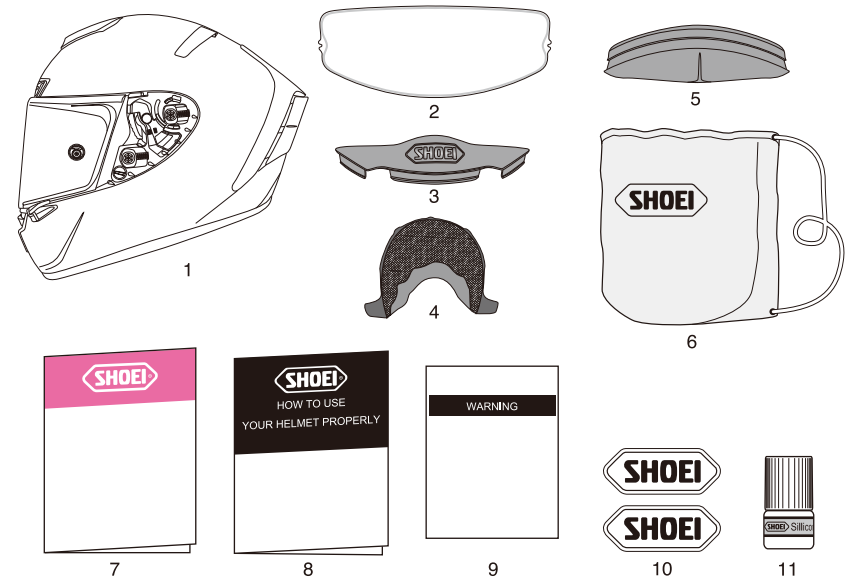

We recommend that you save the box and its cushioning material in case you need to ship the product or its parts for repair. If you dispose of these materials, please follow the proper laws and regulations.

## Parts Description

1. Lower Air Intake
2. Defogger Ventilation System
3. CWR-F Shield / Visor
4. Front Air Intake
5. Upper Air Intake
6. Shell
7. Impact Absorbing Liner
8. Shield / Visor Base
9. Top / Side Air Outlet
10. Rear Stabilizer
11. Rear Flap Wide
12. Chinstrap

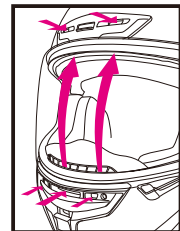
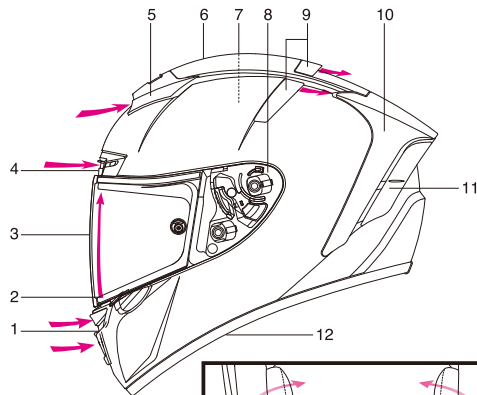

Defogger Ventilation System

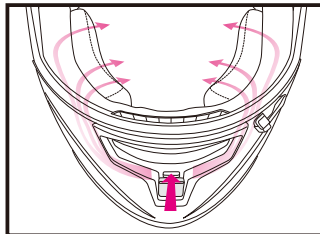

Cheek Vent System

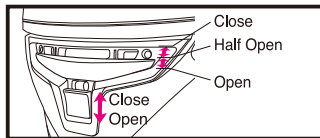

Lower Air Intake

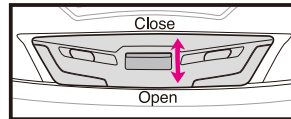

Front Air Intake

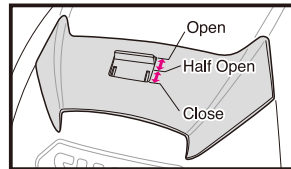

Upper Air Intake /

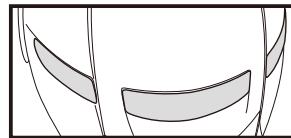

Top / Side Air Outlet

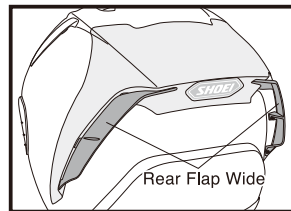

Rear Stabilizer

**!** Opening the vents on the helmet can cause an increase in noise levels.

## Breath Guard

The breath guard reduces fogging of the shield / visor caused by breathing.

To install the breath guard, use the following procedure.

## Installing the Breath Guard

As shown in the drawing, firmly insert the breath guard in the space between the defogger ventilation and the impact absorbing liner.

## Removing the Breath Guard

Pull the breath guard from the space between the defogger ventilation and the impact absorbing liner.

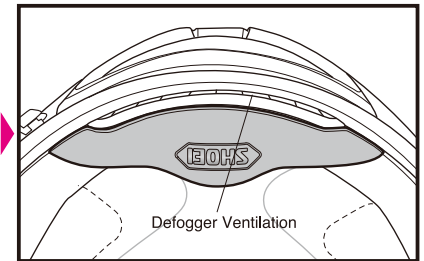
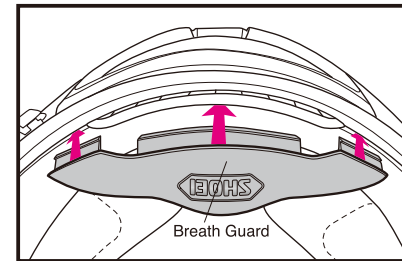

**!** Do not carry or hold the helmet by the breath guard. The breath guard may come off, causing the helmet to drop.

## Applying Silicone Oil

For better sealing of the shield / visor, apply the enclosed silicone oil on the window beading. First, remove any dirt or dust, then apply a small amount of oil to the designated part as per drawing. Wipe away any excess oil. If silicone oil stains the shield / visor, it may obstruct your view. Check for adequate lubrication regularly.

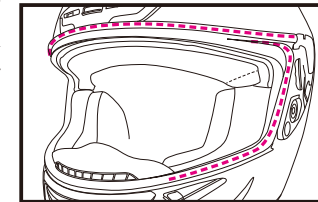

## Lower Air Spoiler & Chin Curtain

Lower Air Spoiler enhances air stream.

### How to Fix Lower Air Spoiler

Insert Lower Air Spoiler into a gap between a shell and an impact absorption liner firmly as per drawing.

### How to Remove Lower Air Spoiler

Pull out plates of both sides of spoiler at first, and then, center portion.

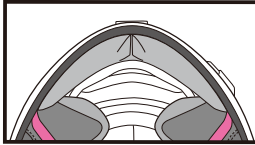
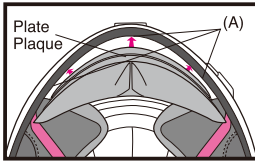

Chin curtain restrains roll-in of wind and invasion of wind noise from chin area. Fix or remove it as below;

### How to Fix Chin Curtain

Align center of plate to center of fore end of helmet and insert it at first, and then, plates of both sides into a gap between a shell and an impact absorption liner.

### How to Remove Chin Curtain

Pull out plate of center area of chin curtain at first, and then, both sides.

\*Lower Air Spoiler may be equipped after chin curtain is equipped.

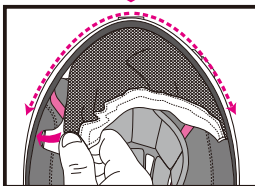
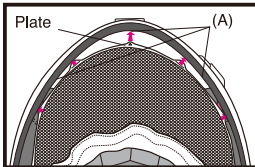

## WARNING

Keep in mind that sounds of cars or motorcycles around you may not be heard loud enough when chin curtain is equipped.



\* Don't hold Lower Air Spoiler or chin curtain when you carry helmet. These parts may come off and helmet may be dropped and damaged.

\* Don't place helmet equipped with Lower Air Spoiler flat long time. Lower Air Spoiler may be deformed.

## CWR-F Tear-off Button

CWR-F Tear-off Button is used to equip CWF-1 Tear-off Film (optional) for races.

When damaged, it may be replaced with optional CWR-F Tear-off Button.

When using CWF-1 Tear-off Film (optional), adjustment of Tear-off Button is required before fixing Tear-off Film. Manual enclosed in CWF-1 Tear-off Film explains how to adjust or how to affix.

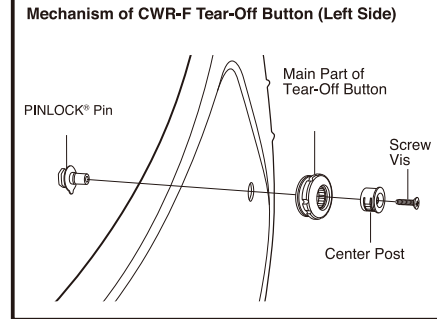

\* Tear-off Button turns anticlockwise. Don't turn it clockwise.

**CWR-F Shield / Visor**

**!** Before using the shield / visor for the first time after purchase, remove the protective film from the shield / visor.

When you close CWR-F shield / visor, shield / visor tab is hooked. Slide lever A (See drawing) upward and lock a shield further. It is recommended to keep locked in this position while riding. Pull down lever A when opening or closing a shield.

**How to Remove CWR-F Shield / Visor**

1. Open a shield / visor to fully opened position as per Drawing 1.
2. Lift a shield / visor pulling a trigger down and release hooks (A) and (B) as per Drawing 2. Then, remove a shield / visor moving it to an arrowed direction as per Drawing 3.
3. Do in the same manner for the other side.

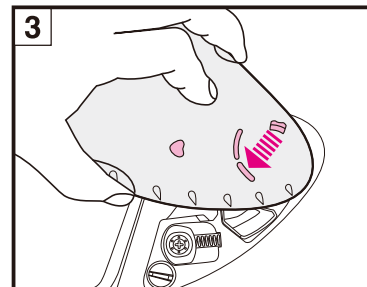
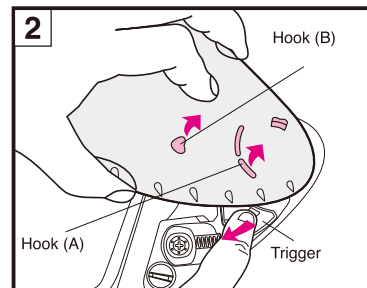
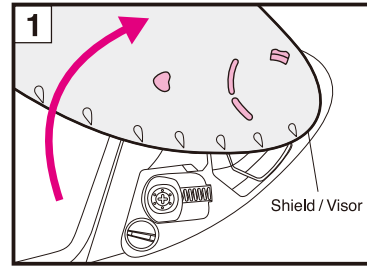
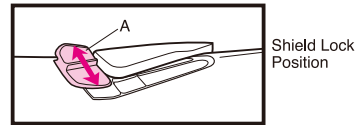
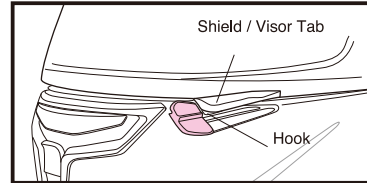
**How to Fix CWR-F Shield / Visor**

1. Adjust a shield / visor to fully opened position and insert shield / visor hook (C) into a hook rail as per Drawing 4.
2. Press an arrowed area of a shield / visor indicated in Drawing 5 until it clicks. Then, insert hooks (A) and (B) securely into positions indicated in Drawing 6.
3. Do in the same manner for the other side.

**WARNING**

If the hook and gear are not securely fastened in the shield / visor base, the shield / visor may come loose while riding and an accident may unexpectedly occur. After installing the CWR-F Shield / Visor, open and close the shield / visor a few times to confirm that the hook and gear fit securely. With the shield / visor completely closed, confirm that the shield / visor tab is clasped by the hook.

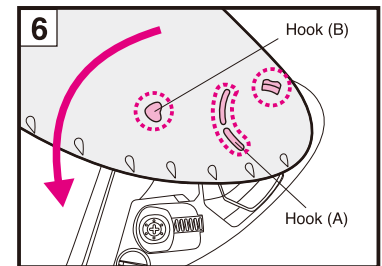
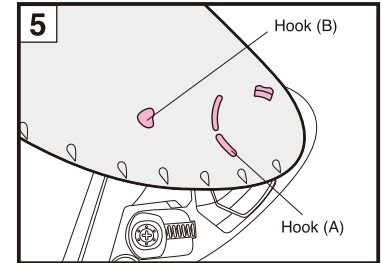
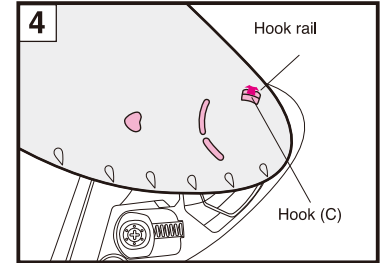

## Important Notice about Handling the CWR-F Shield / Visor

1. Dirt and scratches on the shield/visor may obstruct your view while riding and can be very dangerous! If the CWR-F shield/visor gets dirty or scratched, stop using it immediately. Remove the shield/visor and clean or replace it.
2. The CWR-F shield/visor should be cleaned with a solution of mild, neutral soap and water. Rinse well with pure water then wipe dry with a soft cloth. **Do not use any of the following cleaning materials: hot water over 40°C; salt water; any acidic or alkali detergent; benzine, thinner, gasoline, or other organic solvents; glass cleaner; or any cleaner containing organic solvents.** If any of these cleaners are used, the shield's/visor's chemical nature may be altered and safety may be hindered.
3. Do not ride with a shield/visor that is fogged. This may obstruct your view and can be very dangerous. If the CWR-F shield/visor is fogged, open the lower air intake and/or open the shield/visor to circulate air within the helmet and remove the fog from the shield/visor. Use of the PINLOCK® EVO lens is also effective in stopping fog.
4. Always use SHOEI's genuine PINLOCK® EVO lens for CWR-F. For fitting PINLOCK® EVO lens, please read instructions enclosed in it.
5. Remove the protective film before using the shield/visor for the first time.
6. After cleaning or replacing the base plates, close the shield/visor and make sure that it touches the window beading in all around. If there is a gap between the shield/visor and the window beading, adjust a position of the base plate and eliminate the gap, because it may cause roll-in of wind or noise.
7. For tightening screws, apply No.2 size Phillips head screwdriver vertically and rotate it carefully. If improper sized screwdriver or electric screwdriver is used, a screw head may be broken. Use a genuine screw made of aluminum for replacement. If a screw is tightened too much, it may be broken. (Recommended torque: 80 cN·m or about 8 kgf·cm)
8. Do not place any sticker or tape in the shield's/visor's field of vision.

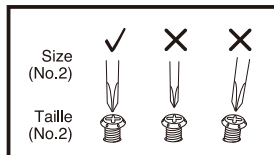

## PINLOCK® EVO lens

If you are using the PINLOCK® EVO lens, read the instruction manual that comes packed with it.



1. Daytime use only. Never use PINLOCK® EVO lens at night. If the PINLOCK® EVO lens is used with a clear shield/visor, its light transmission ratio will be approximately 80%. This value does not meet the light transmission standards in the U.S. (VESC-8, 85%), Australia (AS1609, 85%), or Europe (ECE R22, 80%), so this accessory is for "daytime use only" in these jurisdictions.
2. The PINLOCK® EVO lens is made of a material that is easier to scratch than the outer shield/visor. It should be treated with great care.
3. Remove the protective film before using the PINLOCK® EVO lens.
4. The PINLOCK® EVO lens demonstrates high effectiveness in stopping fog by absorbing moisture. However, if the helmet is used continuously with the lower vent in the closed position in low-temperature, high-humidity conditions, the lens can become saturated with water vapor causing streaks and fog to appear. If streaks or fog appears, it may obstruct your view and be very dangerous! In this case, open the lower air intake and/or open the shield/visor to circulate air within the helmet to remove the streaks and fog from the helmet.
5. Purchase DKS303 for CWR-F for replacement of PINLOCK® EVO lens.

\*PINLOCK® is a registered trademark of PINLOCK SYSTEMS B.V.

## Replacing Interior Parts

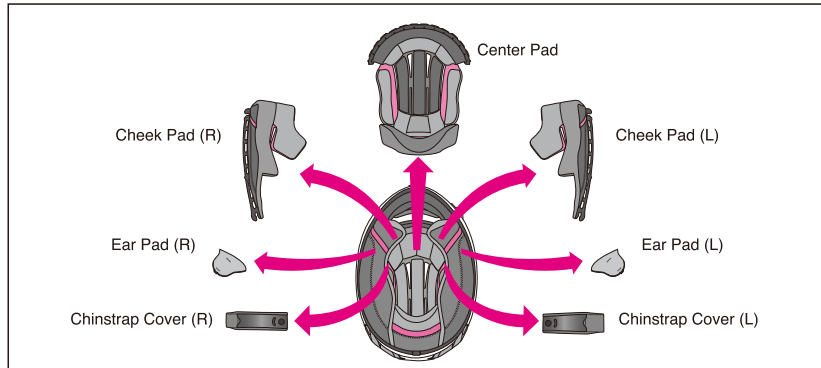

The center pad, the right and left cheek pads and chinstrap covers, and the ear pads can be removed for washing. You can also adjust the fit of your helmet by switching to the optional pads. Look at the list and drawing of interior parts and check whether the parts are installed or removed. Be sure to always fix the center pad, cheek pads, and chinstrap covers prior to riding. If necessary, use the following table to order the proper interior parts to adjust the fit of your helmet.

### Pad Sizes

		XS / S	M	L	XL	XXL
TYPE-I Center Pad	Standard	S	M	L	XL	XXL
	Optional (firm fit)			39		35
TYPE-I Cheek Pad	Standard			35		31
	Optional (loose fit)			31		—

- The same cheek pads can be used with all helmet sizes. For the M size helmet example, choose cheek pad size 31 if you want a looser fit and size 39 for a firmer fit (both are optional parts).
- Center pads will vary by model size. Confirm the size of your helmet prior to making a purchase.

\* Model name and specification vary depending upon country or area.

## Removing Interior Parts

### 1. Removing the Cheek Pads

When the chin curtain is installed, remove it first. Unfasten the 3 snaps to remove the pad from the cheek pad base (Drawing 1). Pull the notch (a) from the cheek pad bracket (A) as shown in the Drawing 2.

Next, pull the notch (b) from the cheek pad bracket (B) as shown in the Drawing 3. Do not pull it hard. **Be sure to pull the front notch (a) out first. If you pull out the rear notch (b), the plate may be damaged.**

### 2. Removing the Ear Pads

Unfasten the 4 clasps on the plate from the cheek pad base (Drawing 4). Remove the ear pad. Remove the other ear pad in the same manner.

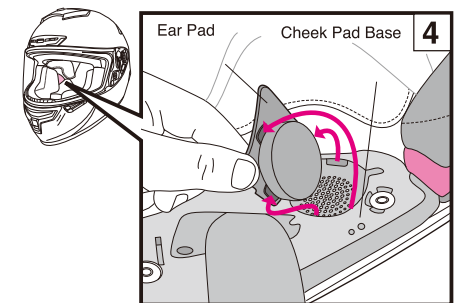
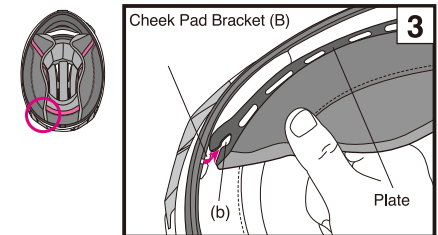
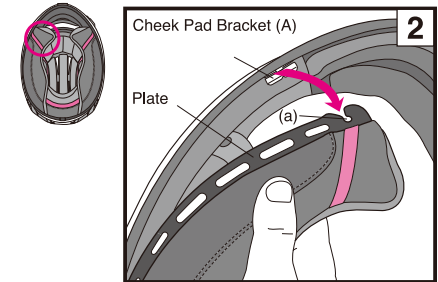
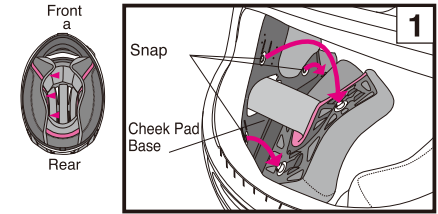

## English

### 3. Removing the Center Pad

Remove the center pad by unsnapping 2 points at the rear of the helmet first (Drawing 5). Pull the front portion of the center pad from the holding plate as per Drawing 6.

### 4. Removing the Chinstrap Covers

Remove the cheek pad then unfasten the chinstrap cover snap. Remove the cover from the chinstrap (Drawing 7). Remove the other chinstrap cover in the same manner.

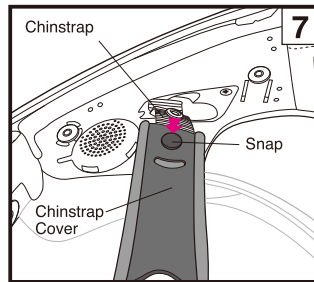
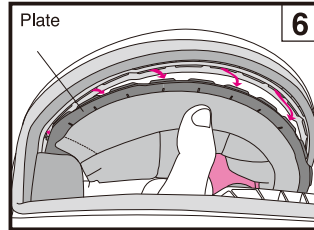
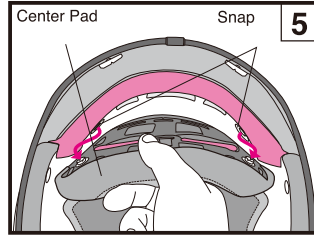

## English

### Ear Pads

The ear pads are designed to reduce wind noise. The ear pads can be removed. To remove or install the ear pads, refer to the "Removing Interior Parts" and "Installing Interior Parts" sections.



With the ear pads are installed, the sound from nearby vehicles will be reduced. Please be aware of this while riding.

## English

### Center Pad

Center pad is composed of front, side, rear, neck and top pads. Fitting may be adjusted by replacing each pad with optional pad. Check fixing positions in the order of 1 to 4 as per drawing before fixing.

#### Disassembled Center Pad Drawing

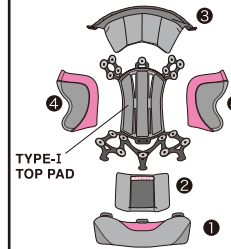

#### ① Equipping Neck Pad

##### TYPE-I NECK PAD COUSSINET DU COU DE TYPE I

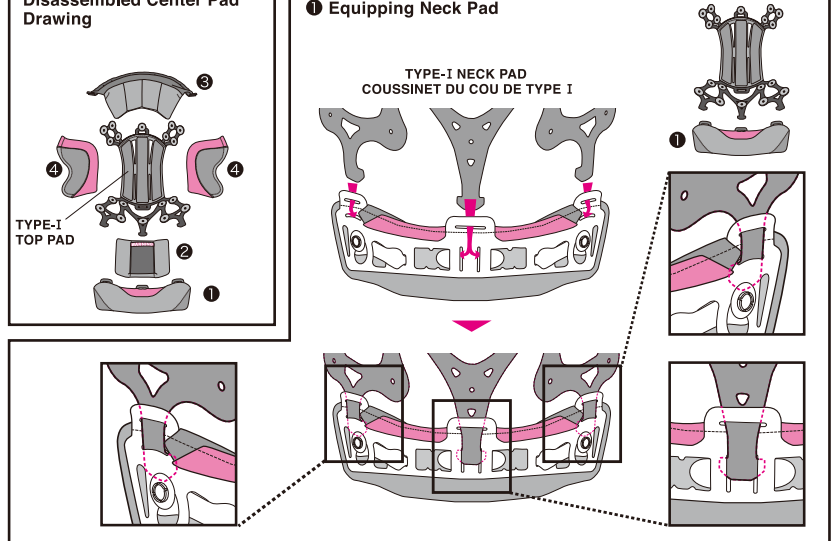

#### ② Equipping Rear Pad

##### English

Align S/L sizes to line of drawing below, not to make a gap between top pads. Fix M/XL sizes 5mm below from top pads.



##### TYPE-I REAR PAD

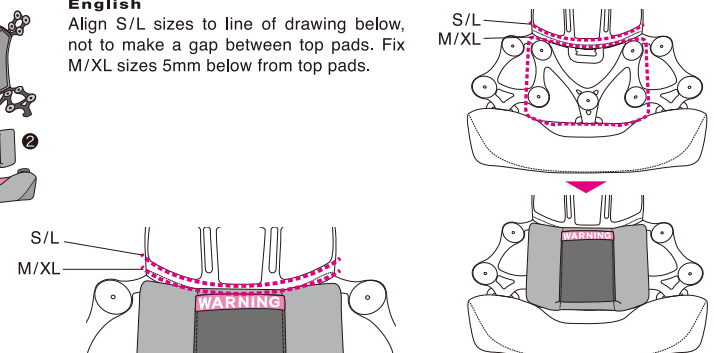



### 3 Equipping Front Pad



#### English

Align S/L sizes to line of drawing below, not to make a gap between top pads. Fix M/XL sizes 5mm below from top pads.

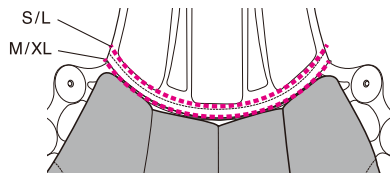
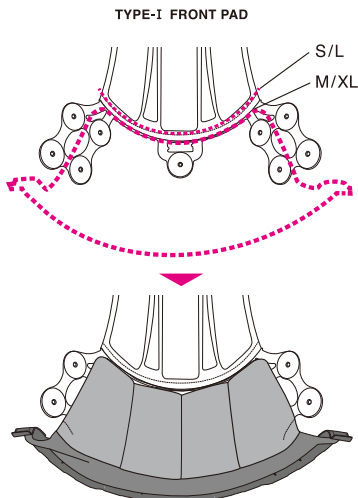

### 4 Equipping Side Pad / Installation du coussinet latéral

#### English

Check right and left sides and adjust corners of pad marked by circle.

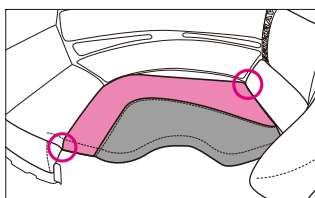

#### TYPE-I SIDE (RIGHT & LEFT) PAD

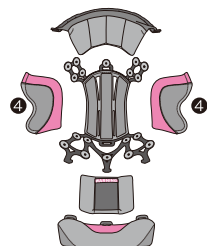

Left

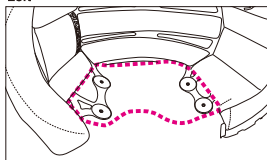

Right

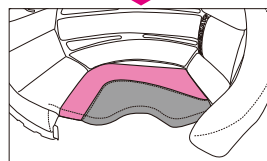
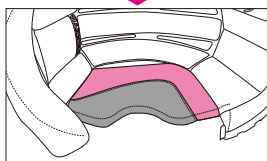
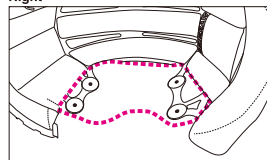

### English

Partial adjustment of size may be made by replacing each of front, side, rear, neck and top pads with optional pad. For instance, when side area of head is tight in M size, it can be eased by changing side pad to optional S5. Pad of each portion of center pad may vary in size of helmet. Check it before purchase.

\*When disassemble each pad of center pad, do it carefully. And also, when fixing or removing neck pad, pay attention not to bend plastic portion.

#### Pad Sizes

##### TYPE-I TOP PAD

	XS	S	M	L	XL	XXL
Optional (firm fit)		S13			L13	
Standard		S9			L9	

##### TYPE-I FRONT PAD

##### TYPE-I REAR PAD/

##### TYPE-I SIDE (RIGHT & LEFT) PAD

	XS	S	M	L	XL	XXL
Optional (firm fit)		S13			L13	L9
Standard		S9			L9	L5
Optional (loose fit)		S5			L5	—

##### TYPE-I NECK PAD

	XS	S	M	L	XL	XXL
Optional (firm fit)		S13	M13	L13		XL13
Standard		S9	M9	L9		XL9

## Adjustment of Equipping position of Interiors

Wearing angle in forward bent posture may be changed to secure vision by changing positions of hooks A and B of back side of cheek pad or position of hook of neck pad.

### TYPE-I Cheek Pad (Right)

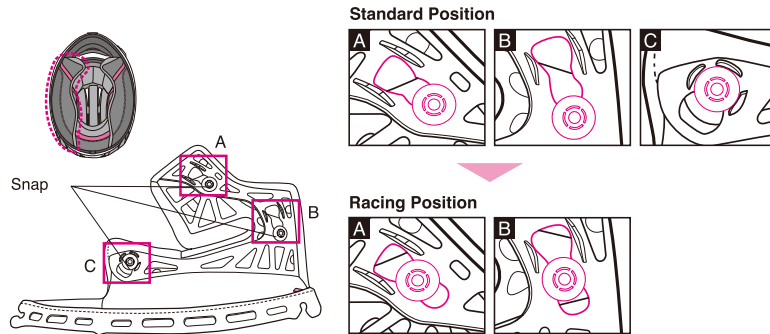

**English**

\*Adjust hooks A and B to the same positions in the same manner for opposite side.

\*Don't move hook C from position of drawing.

### TYPE-I NECK PAD

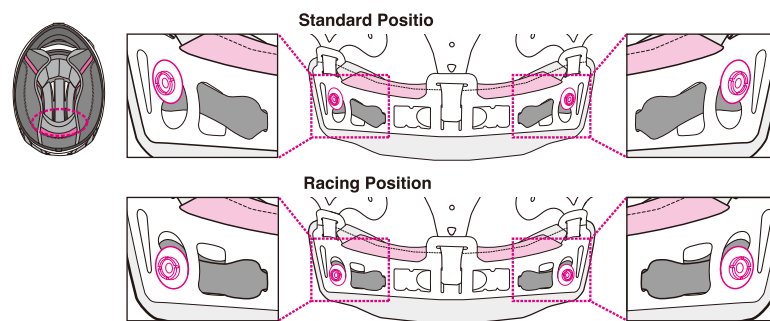

## Installing Interior Parts

### 1. Installing the Chinstrap Covers

The chinstrap covers have different shapes on the right and left sides of the helmet. Pass the chinstrap through a chinstrap cover and snap each other until you hear it clicks (Drawing 8).

### 2. Installing the Center Pad

Slide and insert front plate into a gap of bracket from one side to another as indicated in Drawing 9 and 10. Snap the two snaps into place in the rear of the center pad as per Drawing 11.

### 3. Fixing of Ear Pad

Check right and left sides of ear pads and place it adjusting to dotted line of drawing 12. Then, adjust 4 catches to cuts of cheek pad base and press pad. Do in the same manner for other side.

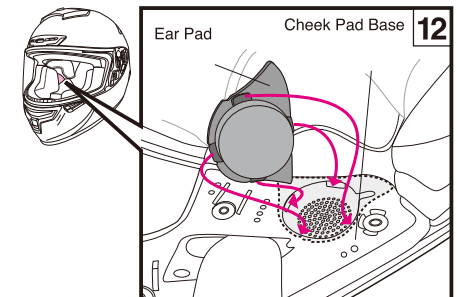
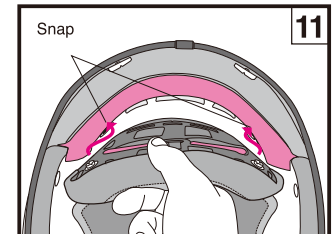
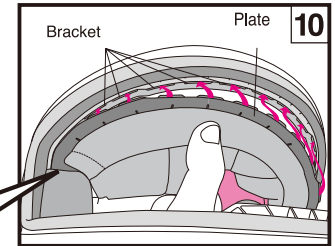
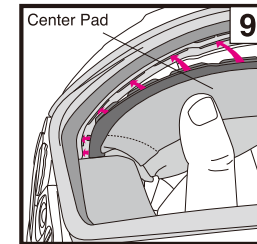
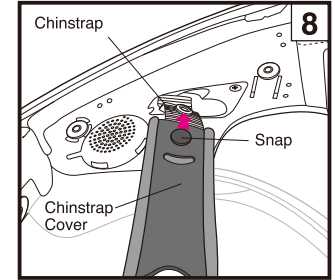

#### 4. Installing the Cheek Pads

Make sure that hooks A and B are in a standard position or a racing position and that hook C is in a position shown in drawing before equipping cheek pad to helmet.

Identify a right pad and a left pad. Insert a groove (b) of a rear portion of plate into a boss of a cheek pad bracket (B) as per Drawing 14. Then, do frontward and insert a groove (a) of a plate into a cheek pad bracket (A) as per Drawing 15. Make sure to insert a plate deeply. After the plate is inserted, pass the chinstrap through the hollow section of the cheek pad (Drawing 16). Fasten the snaps in ❶ to ❸ order, by pressing the head of the snaps firmly from the pad side until they click in place. Lastly, press the corner (A) of the pad as shown in the Drawing 17 and fit the cheek pad plate securely into the boss of the cheek pad base. Install the other cheek pad in the same manner.

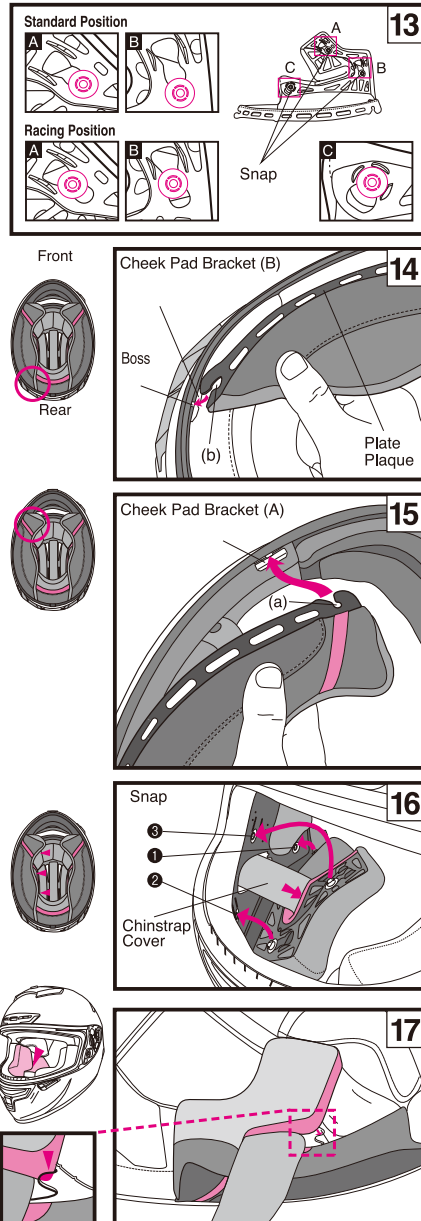

#### Important Notice about Handling Interior Parts

- When fastening or unfastening the snaps, you should hold near the snaps and treat carefully. Fasten the snaps firmly until they click in place.
- You can clean the inner parts by hand washing them or by washing them in a washing machine after placing them in a laundry net. Please treat them carefully when washing. Use lukewarm water. Gently squeeze the parts with a dry towel and dry them in the shade. To prevent damage to the plastic areas of the interior parts, do not wring them strongly and do not fold or bend the plastic areas. Take special care if you are using a washing machine. Do not dry the interior parts with a clothes dryer, blow dryer, or any other type of mechanical dryer, as heat can damage the material. The impact absorbing liner (polystyrene foam section) should be wet with a soft cloth dipped in a solution of mild neutral soap and water and then wiped. Allow time for the impact absorbing liner to dry in the shade. Do not dry the impact absorbing liner in the sunlight or use any type of mechanical dryer, as the impact absorbing liner is extremely sensitive to heat. If the impact absorbing liner is exposed to high heat of any kind, contact your dealer or SHOEI directly for a safety evaluation. To prevent damage, **do not use any of the following cleaning materials: hot water over 40°C; salt water; any acidic or alkali detergent; benzine, thinner, gasoline, or other organic solvents; glass cleaner; or any cleaner containing organic solvents.**
- When washing center pad, put it in washing net in an assembled position of all parts (front, rear, side, top and neck pads). When each pad is disassembled and washed separately, flat fastener may be damaged.

## E.Q.R.S. (Emergency Quick Release System)

E.Q.R.S. (Emergency Quick Release System) is a mechanism for emergency personnel to remove the cheek pads.

To remove a cheek pad in an emergency, cut or undo a chinstrap first. While holding the helmet firmly so that the rider's head may not move, take emergency strip (Drawing 1) and pull it to a direction indicated in the Drawing 2. (If chin curtain and/or Lower Air Spoiler is equipped, it must be removed before using the emergency strip.)

Pulling the emergency strip will release snaps and allow a cheek pad to be pulled out through the bottom of the helmet while it is still on the rider's head. Repeat the same procedure to remove the other side.

Be sure to hold the helmet firmly and pay full attention not to move the rider's head while removing the cheek pads.

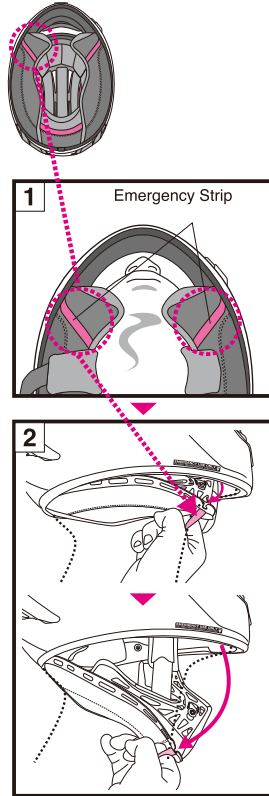

## WARNING

1. Before use, check that the shield / visor hooks and gears are fit firmly.
2. Be sure to always wear the center pad, cheek pads, and chinstrap covers when using the helmet.
3. When cleaning and caring for the helmet and shield / visor, **do not use any of the following cleaning materials: hot water over 40°C; salt water; any acidic or alkali detergent; benzine, thinner, gasoline, or other organic solvents; glass cleaner; or any cleaner containing organic solvents.** If any of these cleaners are used, the helmet's chemical nature may be altered and safety may be hindered.
4. If insects become stuck to the helmet during riding and are left in place, the helmet surface may be corroded. They should be removed promptly.
5. Be sure to use SHOEI genuine parts when replacing the outer shield / visor or inner parts.

### ⚠ Warnings

1. Make sure to hold the helmet firmly by your hand when pulling out cheek pads.
2. Never pull the emergency strip while riding.
3. Use genuine SHOEI cheek pads only and never use non-SHOEI parts.
4. If a chin curtain and / or a lower air spoiler is installed in the helmet, remove the chin curtain and / or the lower air spoiler before handling the emergency strip.
5. Do not use Emergency Quick Release System when removing a cheek pad for maintenance.

**EMERGENCY USE ONLY**  
PULL RED TAB AND REMOVE CHEEK PAD

◀ Never peel these stickers from a helmet.

**Parts List**

These optional parts are available for repair or replacement.

To replace the parts, read the instruction manual that comes packed with the parts.

- CWR-F Shield / Visor
- QR-E Shield / Visor Base Plates (right and left)
- Q.R.S.A. screws
- QR-E Shield / Visor Base Plates & Screw Set
- PINLOCK® EVO lens for CWR-F (DKS303)
- CWR-F Tear-Off Button
- Upper Air Intake
- Front Air Intake
- Top Air Outlet
- Lower Air Intake
- Side Air Outlet
- Rear Flap Wide
- Rear Flap Narrow
- TYPE-I Center Pad
- TYPE-I Cheek Pad (right and left)
- TYPE-I Front Pad
- TYPE-I Rear Pad
- TYPE-I Side Pad(right and left)
- TYPE-I Neck Pad
- TYPE-I Top Pad
- X-Spirit III / Fourteen Chinstrap Covers (right and left)
- Ear Pad D (right and left)
- Breath Guard J
- Chin Curtain D
- X-Spirit III / Fourteen Lower Air Spoiler