

1.

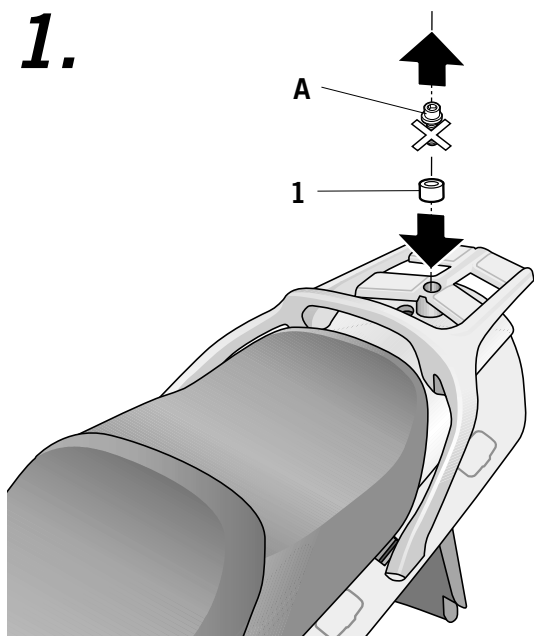

Advice for correct fitting of the kit: Do not fully tighten the screws until sure that the kit is correctly positioned and aligned.

Unscrew and remove screw (A) from the rear carrier. Position the spacer (1).

2.

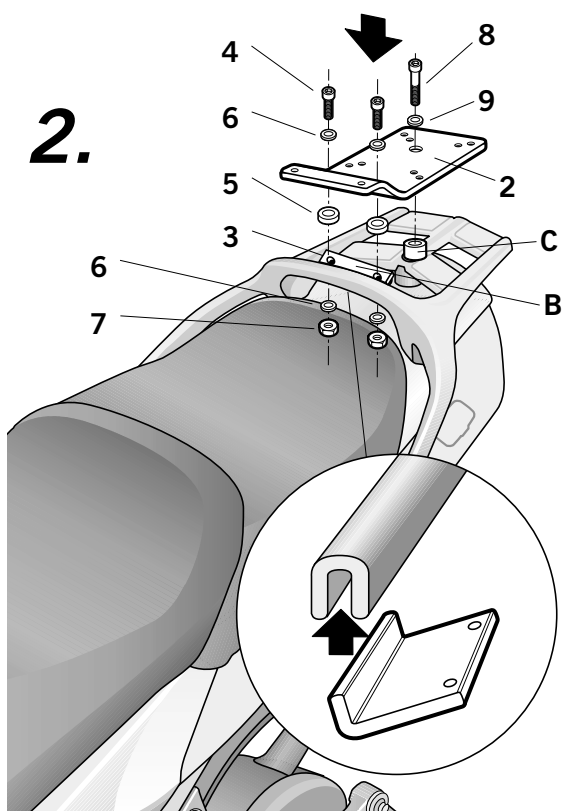

Position the kit support top (2), jointly with the bridle panel (3), attach it as shown in the diagram. Fix it in area (B), using screws (4), spacers (5), washers (6) and nuts (7). In area (C), using screw (8) and washer (9).

PARTS :

Pos.	Ref.		Cant.	
1	260417		1	ø16 ø9 x 16 - Spacer
2	260669		1	Kit Top
3	260827		1	Bridle panel support -
4	304057		2	M6 x 25 DIN 912 - Screw -
5	260648		2	ø16 ø9 x 5 - Spacer
6	303017		4	Ø18 Ø6 - Washer
7	302021		2	M6 - Nuts
8	304067		1	M8 x 65 DIN 912 - Screw
9	303020		1	Ø8 - Washer

YAMAHA FJR 1300 '01
YOFJ31ST
KIT TOPMASTER



SHAD

Find out more about luggage systems & saddlebags we have.