

SADDLE BAGS

Ref: X0SE48

 SIDE BAG HOLDER (FITTING SYSTEM)

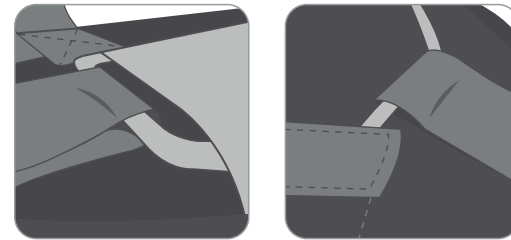
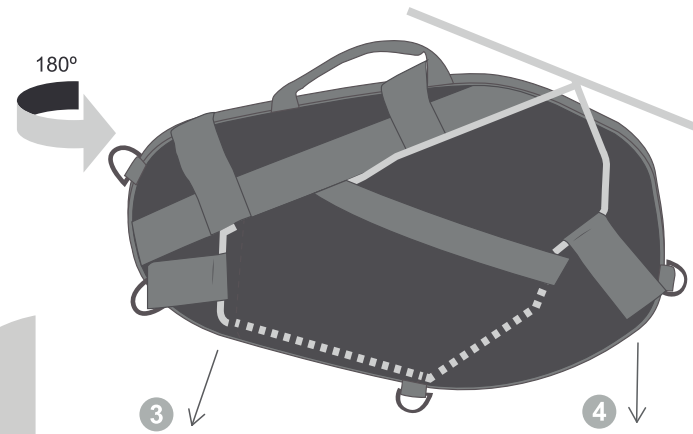
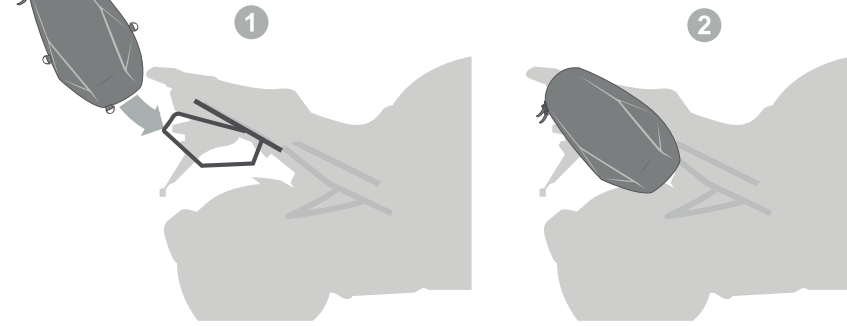

6

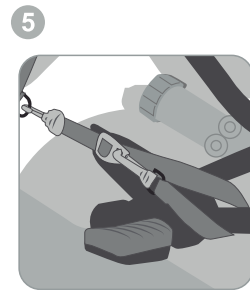
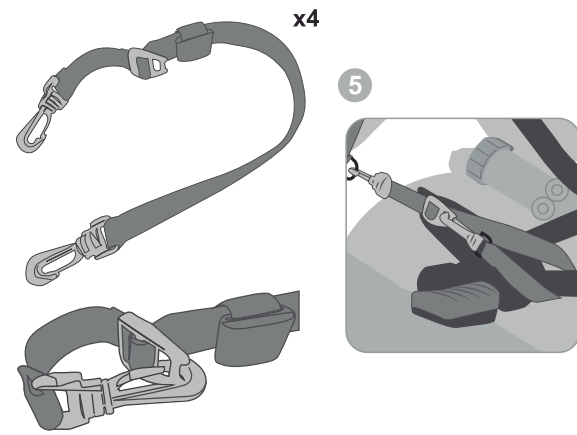

 40 - 52L
SET of 2

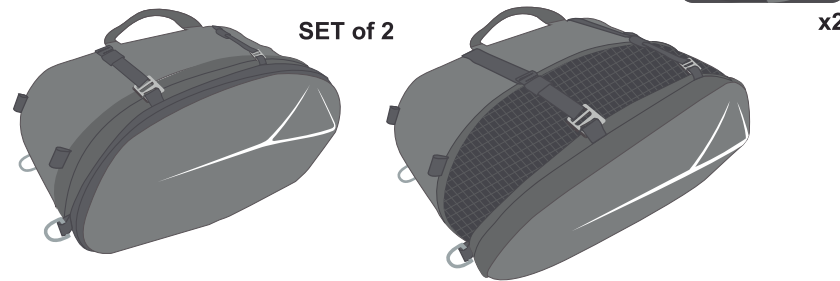

 Rain cover

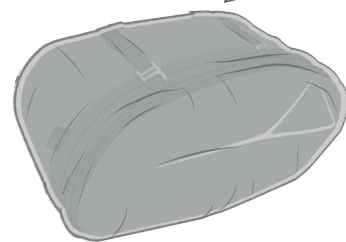

FIXATION WITHOUT SIDE BAG HOLDER

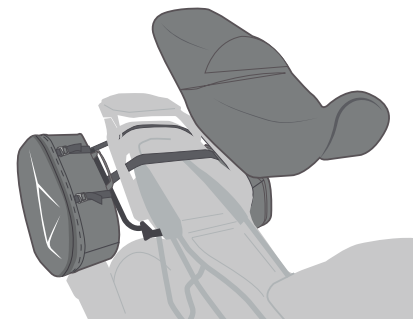

INSULATION THERMAL PAD - ACCESSORY -



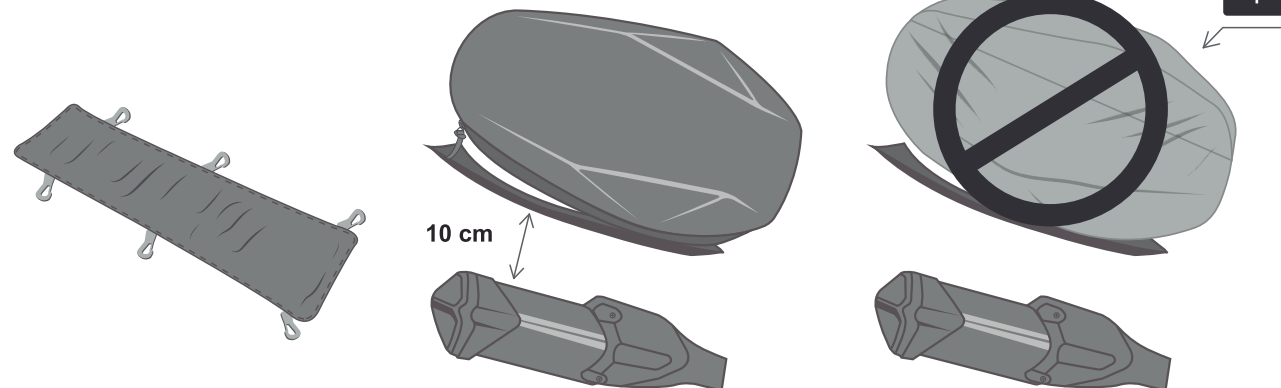







Ref: X1SB97



SHAD SOFTBAGS







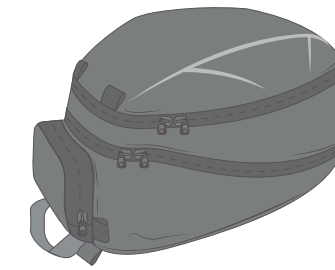





Ref: X0SE04
Name: Tank Bag 3L

	Semi rigid
	Capacity 3L
	Water resistant zipper
	Universal base tank
	Inner pockets
	Reflective
	Rain cover
	Outlet for USB charger
	Mobile phone holder
	Touch screen









Ref: X0SE22
Name: Tank Bag 16L

	Semi rigid
	Capacity 16L - 21L
	Water resistant zipper
	Universal base tank
	Inner pockets
	Reflective
	Rain cover
	Outlet for USB charger
	Compression straps
	Expandable
	Shoulder strap







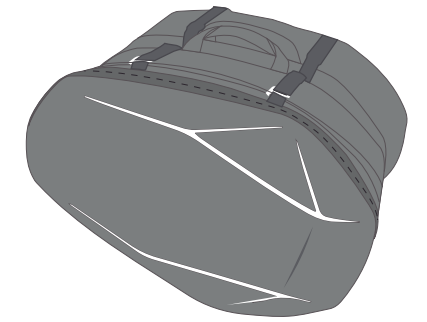



Ref: X0SB83
Name: Backpack with laptop protection

	Semi rigid
	Capacity 17L
	Water resistant zipper
	Helmet holder
	Inner pockets / laptop compartment
	Reflective



Ref: X0SE48
Name: Saddle Bags

	Semi rigid
	Capacity 40L - 52L
	Water resistant zipper
	Expandable
	Compression straps
	Reflective
	Rain cover
	Inner reinforcement

⚠ WARNING

Clean the tank of the bike before placing the Universal Base Tank to avoid scratches in the paint.

Make sure the bag and its accessories are properly assembled.

When cleaning the bags use a damp cloth with neutral soap, always avoid using solvents or chemical products.

Prolonged exposure to weather might discolor fabrics and wear away plastic components.

Waterproof zippers and rain covers do not guarantee that the bag is fully water resistant.

Use zippers with care. To open the bags slide zip all the way without forcing.

The maximum speed of the motorcycle with the bag must not exceed 120 Km/h / 74 Mph (this may vary depending on the legislation of each country).

Load capacity. Tank bag SE-22: 2 Kg (4 Lb) max. Saddle bags SE-48: 2 Kg (4 Lb) / each max. Backpack SE-83: 3 Kg (6 Lb) max.

SHAD will not hold responsibility for damages caused by an incorrect assembly.

UNIVERSAL BASE TANK

Included in Tank bags E-04, E-22

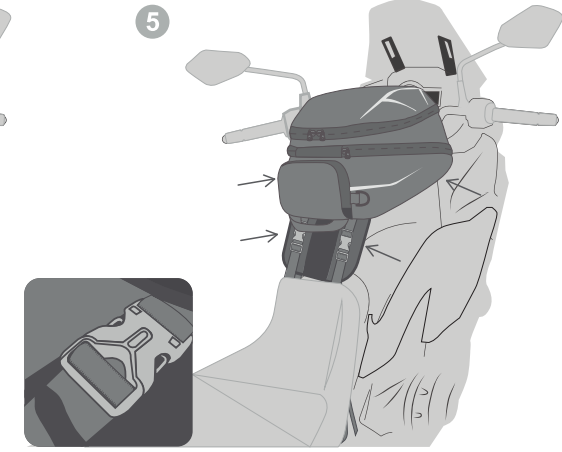
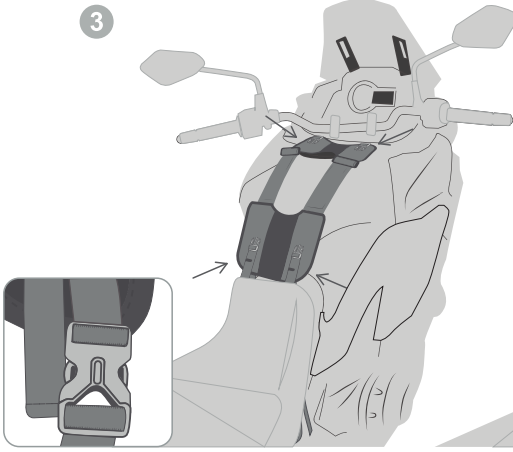
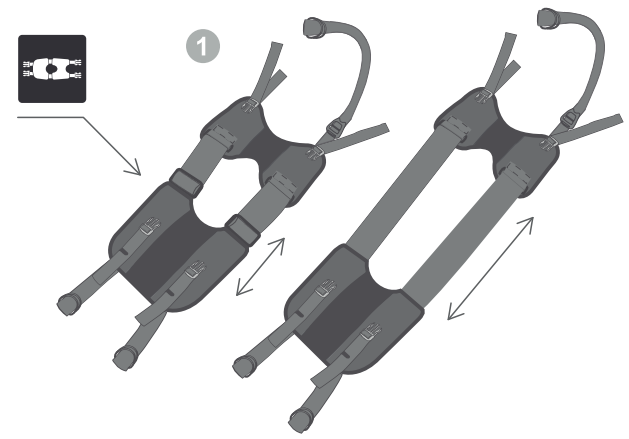

x4

x4

SMALL TANK BAG E-04

Ref: X0SE04

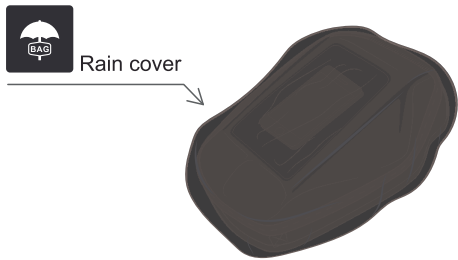
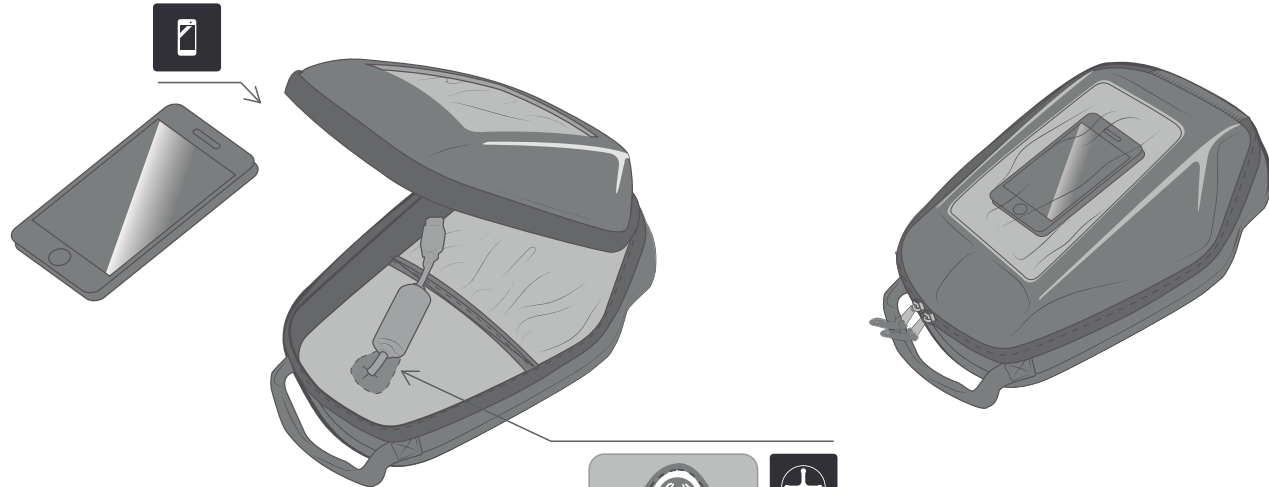

Cable outlet for USB
Universal adapter for
motobike X1 SB95

OPTIONAL ACCESSORIES - SOLD SEPARATELY



USB Universal Moto Charger
Ref: X1SB95



Magnets system
Ref: X1SL11

TANK BAG E-22

Ref: X0SE22

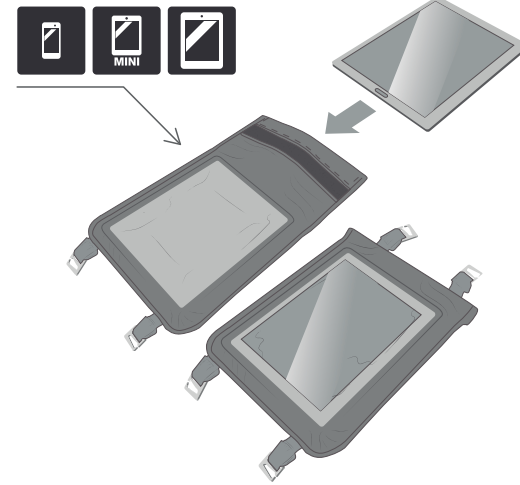

Mobile/Tablets holder
Optional Accessory - Sold separately

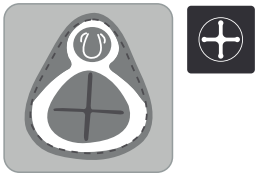
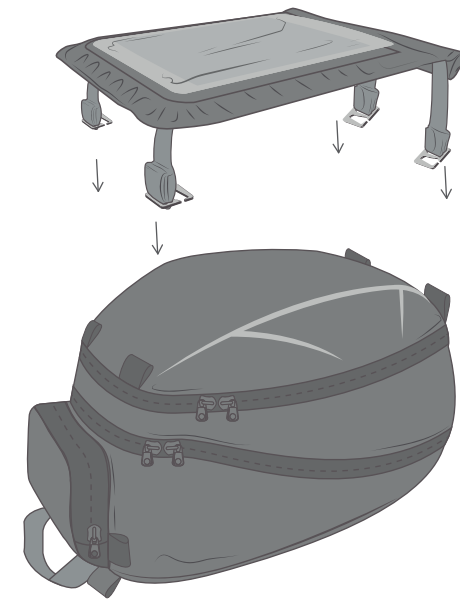

Cable outlet for USB
Universal adapter for
motobike X1SB95



16 - 21L

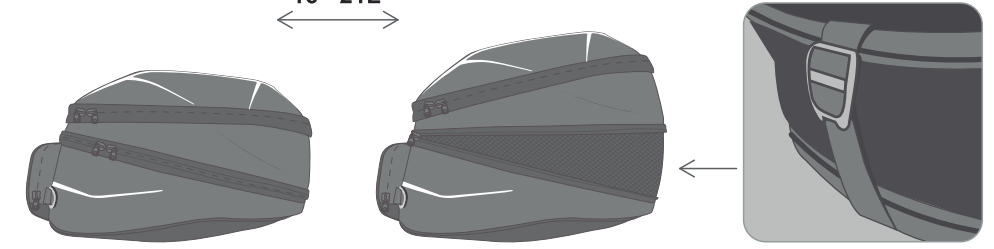

Adjustable buckle

OPTIONAL ACCESSORIES - SOLD SEPARATELY



USB Universal Moto Charger
Ref: X1SB95



Magnets system
Ref: X1SL11



Mobile/Tablets holder
Ref: X1SE22

BACKPACK E-83

with laptop protection
Ref: X0SE83

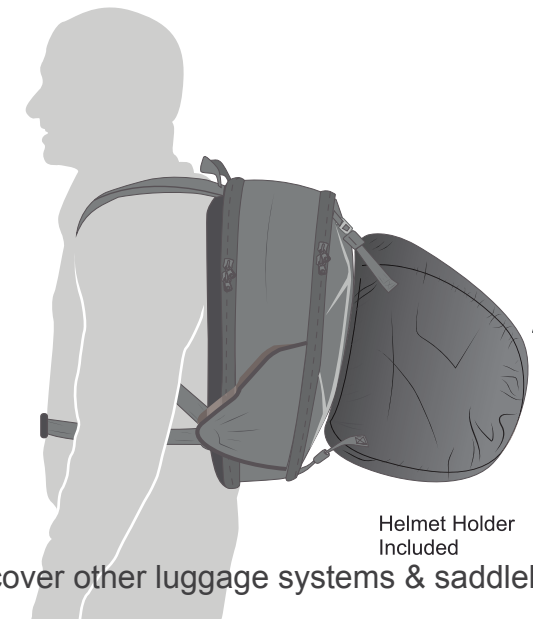

Helmet Holder
Included

Discover other luggage systems & saddlebags on our website.