

1.

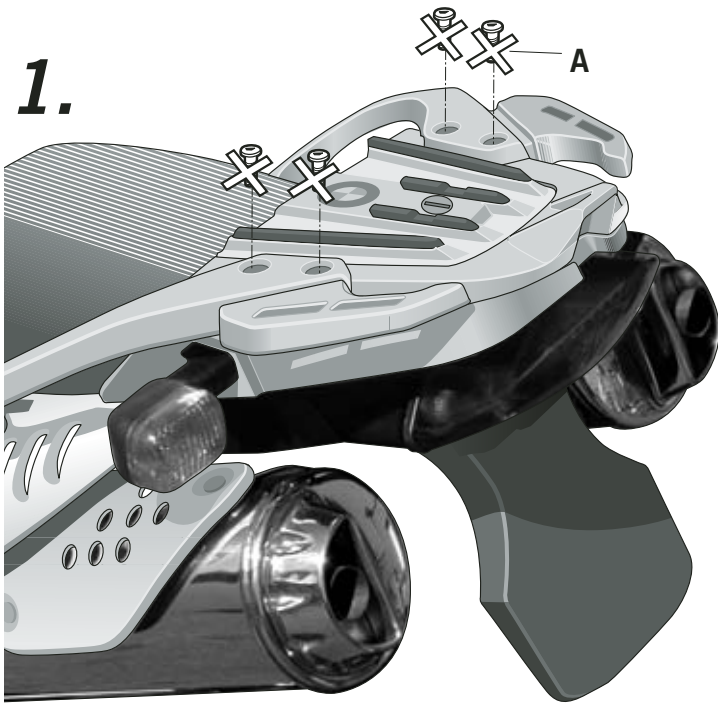

Remove and put aside the screws (A) of the original rear carrying case.

2.

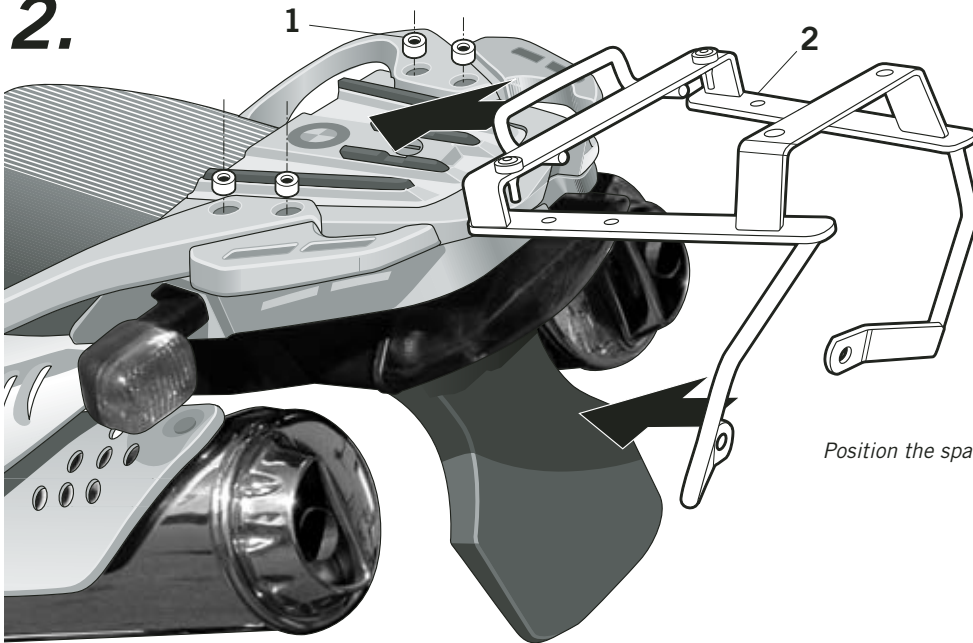

Position the spacers (1).

3.

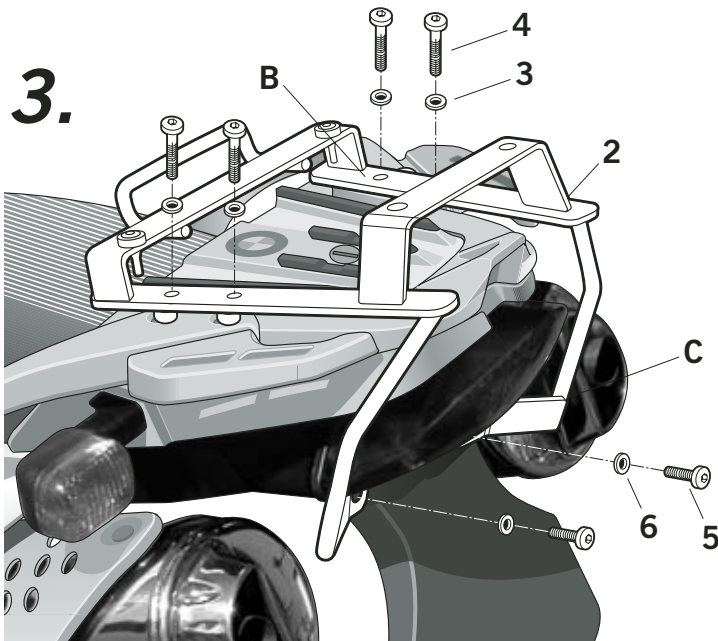

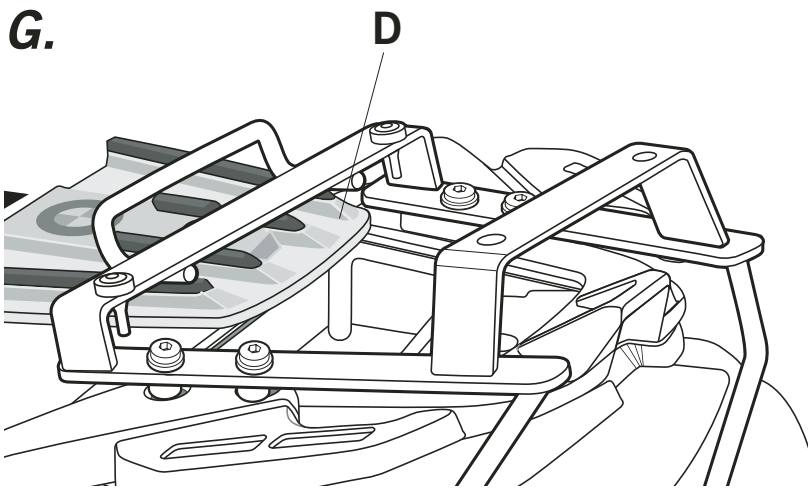
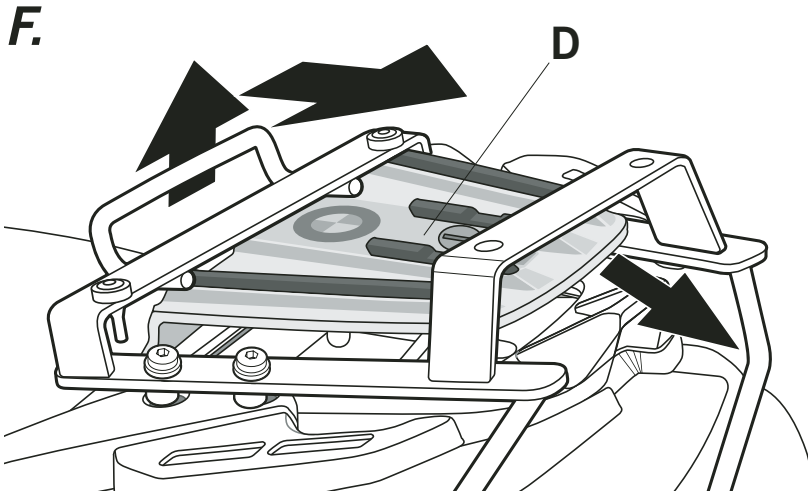
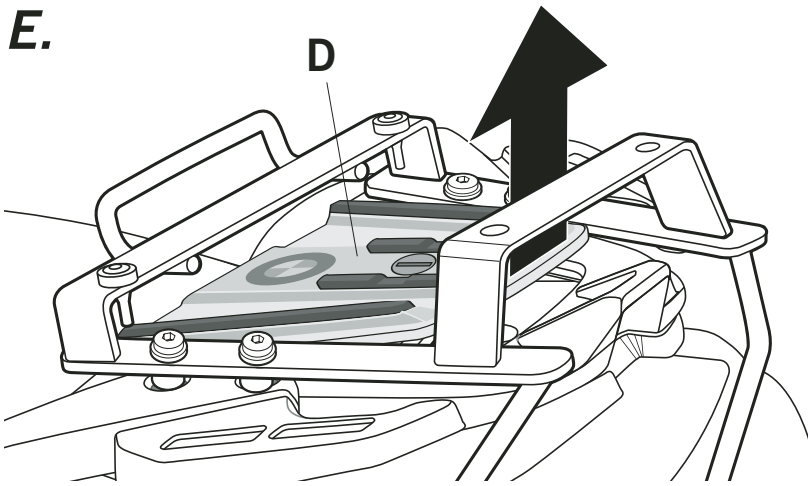

Next, assemble the Kit Top support (2) in area (B) using the spacers (1), washers (3), and screws (4). And in area (C) using the screws (5) and the washers (6).

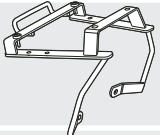

To be able to disassemble the cover of the rear carrying case (D) of the motorcycle, follow the steps as shown in our diagrams (E-F-G).

**PARTS :**

Pos.	Ref.		Cant.	
1	260686		4	Ø16 x Ø9 x 8 - Distancers
2	260959		1	KIT TOP
3	303021		4	M6 - Washer
4	304071		4	M6x50 DIN 912 - Screw
5	303020		2	M8 DIN 125 - Washer
6	304033		2	M8x25 DIN 912 - Screw

