

1.

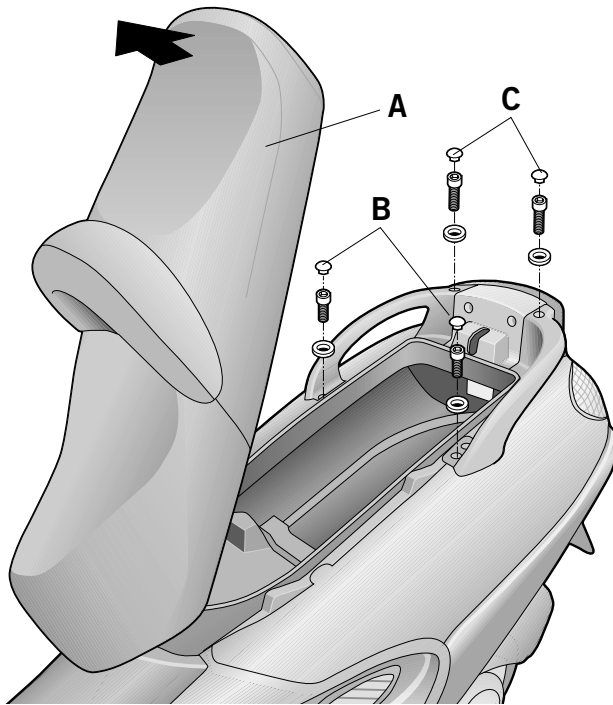

Open the seat (A).
Loosen and remove the covers (B) and (C).

2.

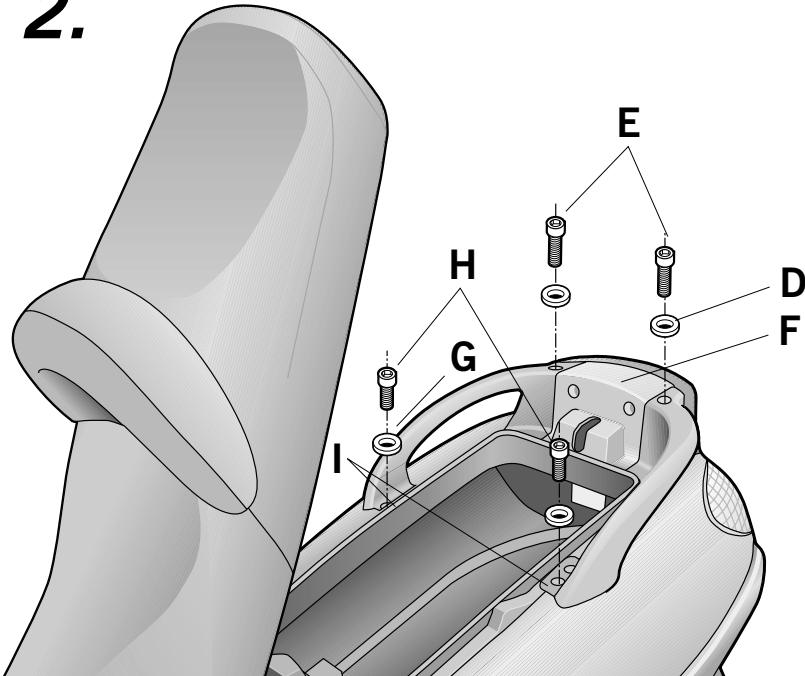

Loosen and remove the washers (D) and the screws (E) in the zone (F), and the washers (G) and the screws (H) in the zone (I).

3.

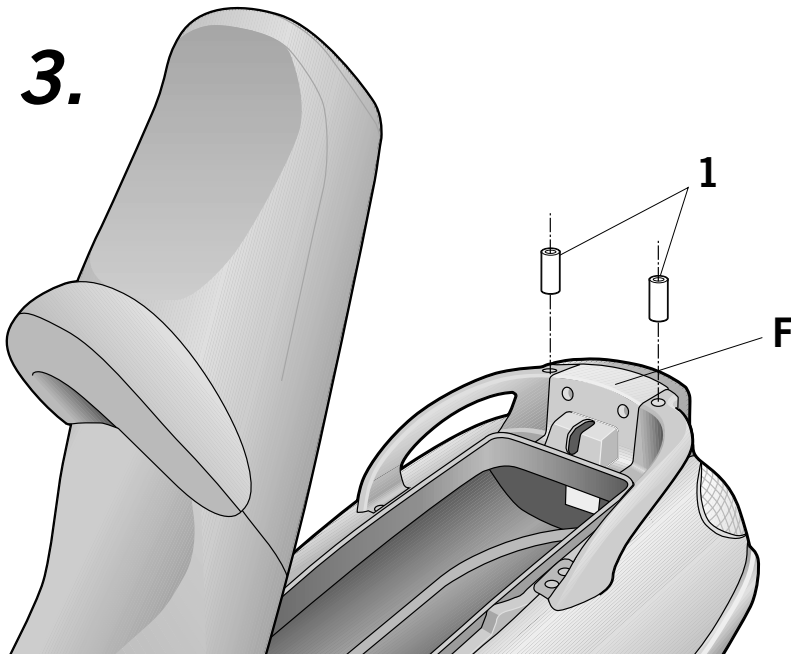

Place the spacers (1) in the zone (F).

PIAGGIO X-9 250 '01 - AMALFI 180 '03
KIT TOPMASTER
VOX20T



SHAD

4.

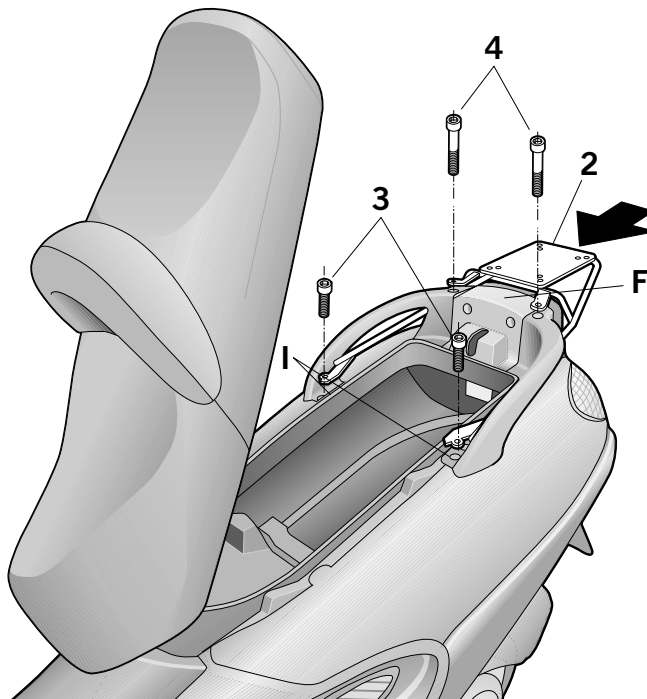

Assemble the KIT TOP (2) with the screws (3) in the zone (I), and screws (4) in the zone (F).

5.

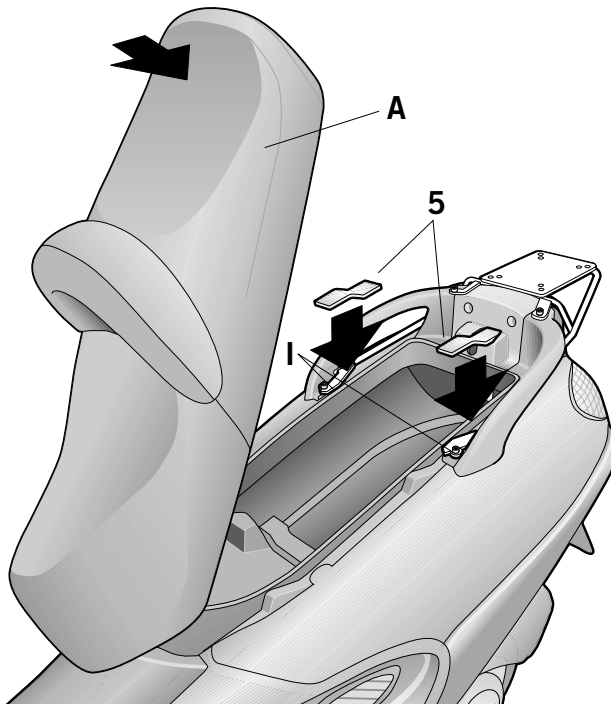

Place the foam protection (5) in the zone (I).
Close the seat (A).

PARTS :

Pos.	Ref.		Cant.	
1	260611		2	∅13 x 68 - Spacer - Entre-toise
2	260612		1	Kit top
3	304061		2	M6 x 60 DIN 7991 - Screw
4	304153		2	M6 x 110 DIN 912 - Screw
5	260291		2	Adhesive foam