

Ⓜ Advice for correct fitting of the kit: Do not fully tighten the screws until it is ensured that the KIT is correctly attached and aligned.

1.



Ⓜ Disassemble the plastic embellisher (A). Make three Ø18 holes in the plastic embellisher (A) following the three marks found in the inferior part of the luggage rack (B). Once the three holes have been made, reassemble the plastic embellisher (A).

2.

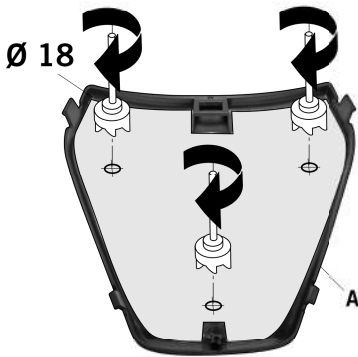

Ⓜ NOTE: For the Beverly sportouring 350/350i'12 model, a holes must be made over the plastic trim (A) using the template included in the instructions, and the spacer (6) in posterior area.

3.

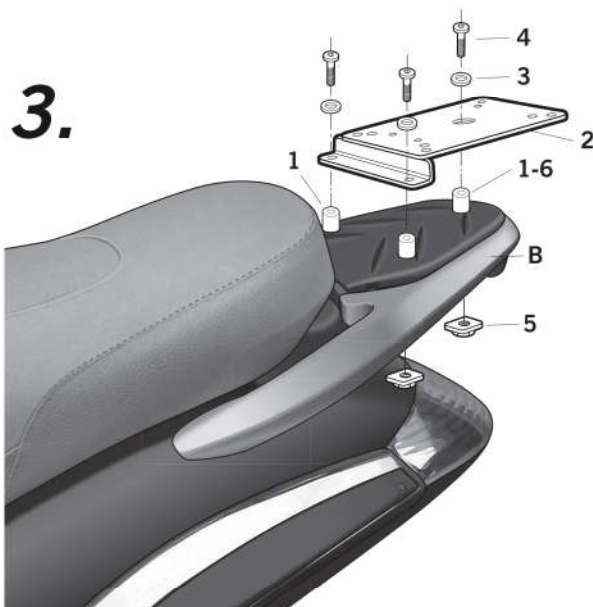

Ⓜ Place the cases (1) over the original luggage rack (B). Assemble the KIT TOP support (2) to the original luggage rack (B) by means of the cases (1), the washers (3), the screws (4) and the fixing plate M8 (5).







PIAGGIO BEVERLY TOURER 125/250/400 08

VOTR18ST

KIT TOPMASTER

SHAD

PARTS

Pos.	Ref.		Cant.	
1	260596		3	Ø16 Ø9 x 20 - Spacer
2	261158		1	KIT TOP
3	303020		3	Ø8 - Washer
4	304036		3	M8 x 45 DIN 7380 - Screw
5	260888		3	Fixing Plate M8
6	260213		1	Ø16 Ø9 x 12 - Spacer - Entre-toise

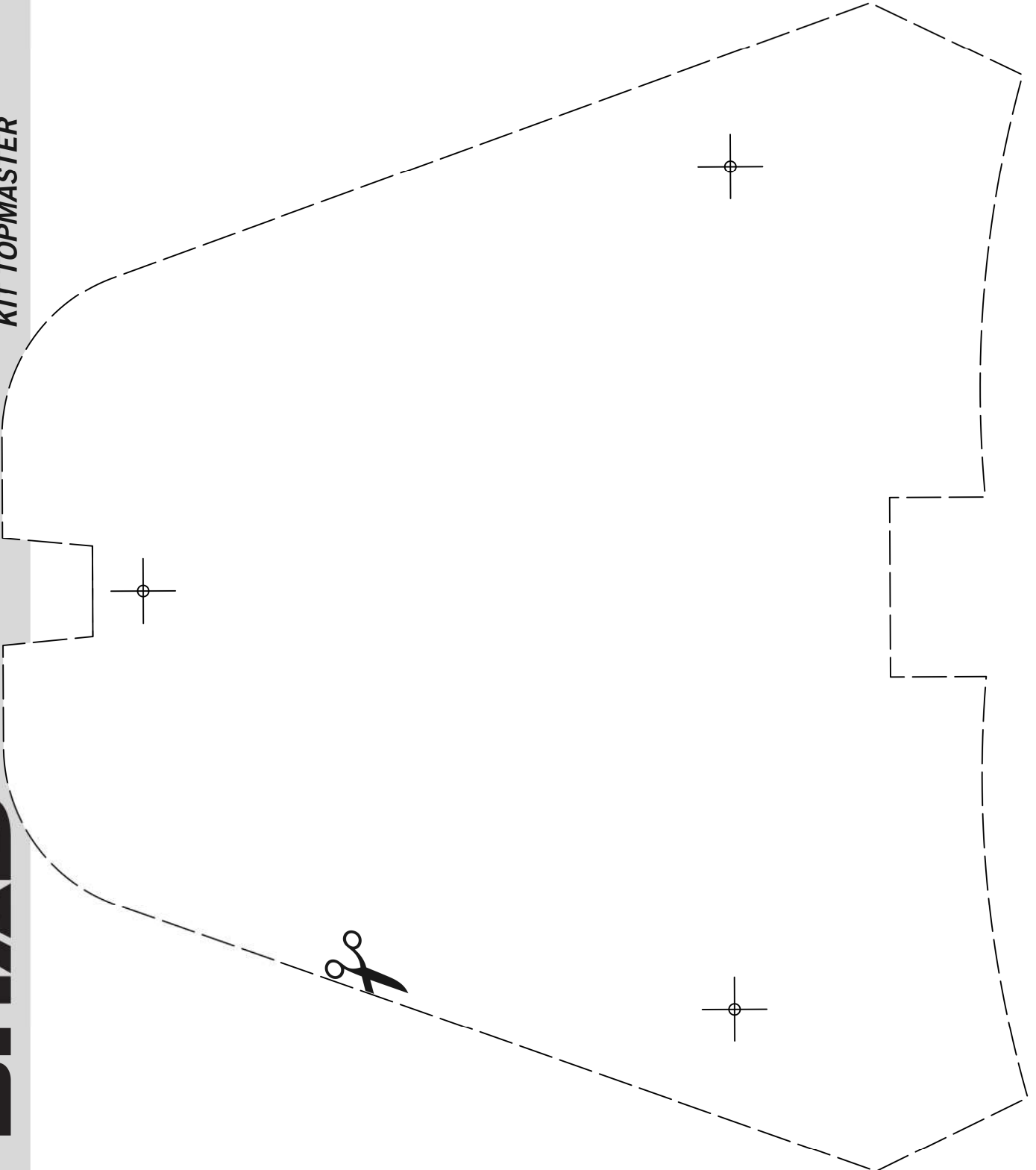

Discover other luggage systems & saddlebags on our website.