

PROPER KIT ASSEMBLY: do not tighten the screws until ascertaining that the kit is properly positioned and aligned.

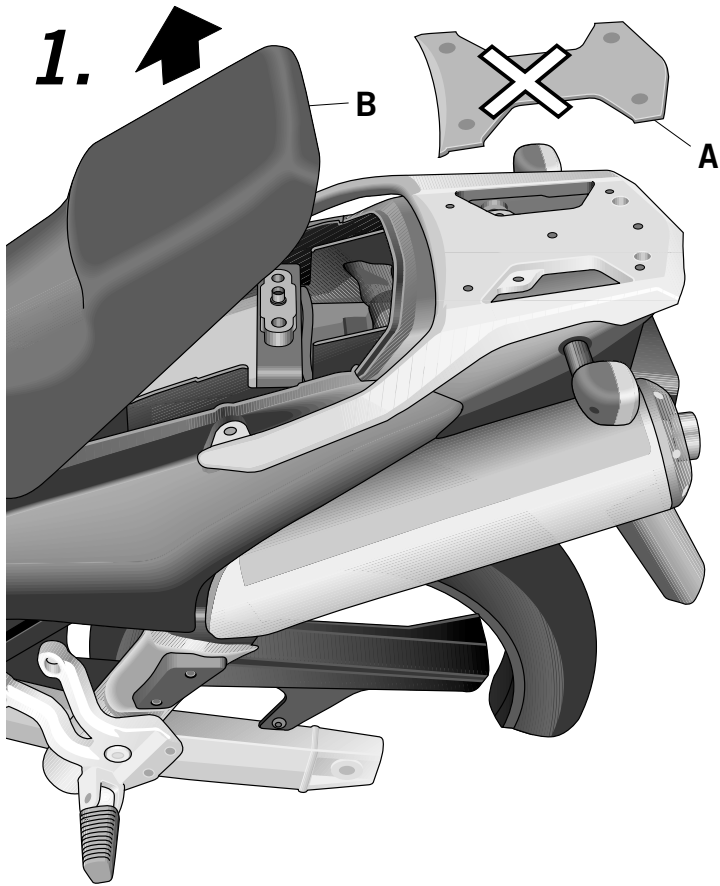

Dismantle and remove the protective rubber (A). Dismantle the seat (B).

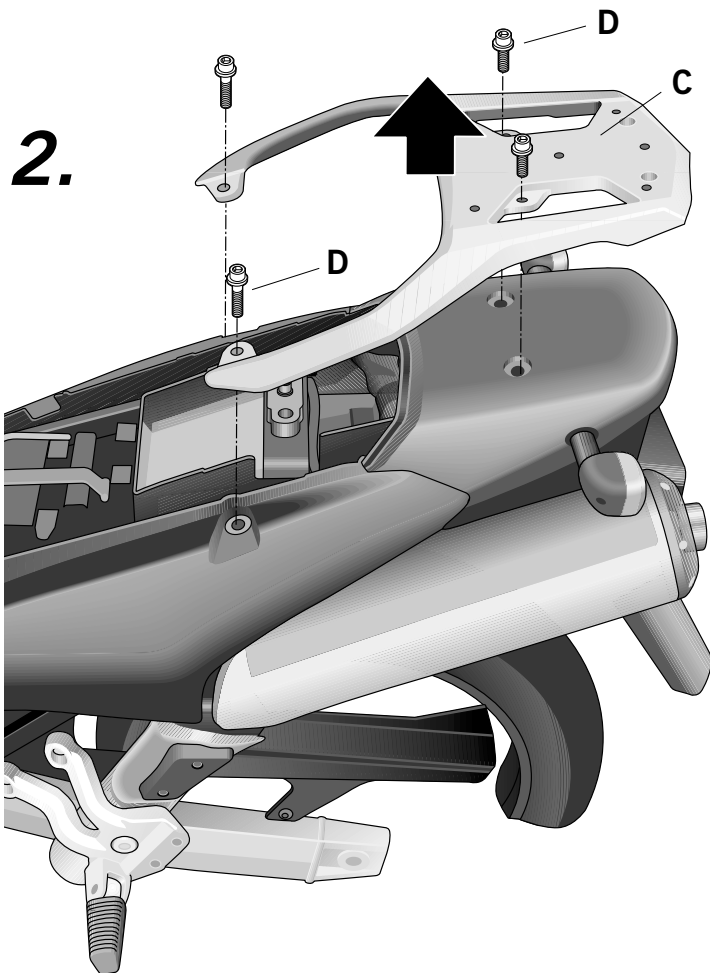

Dismantle the original carrier (C), using screws(D).

SUZUKI V-STROM DL 1000 '02
KIT TOPMASTER
SOVS12ST



SHAD

3.

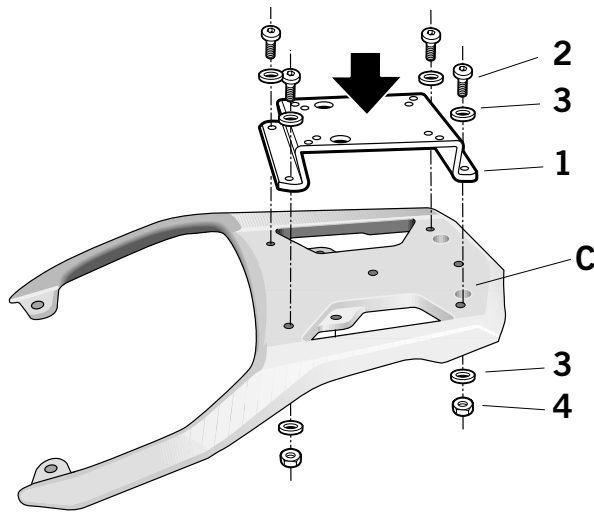

Attach KIT TOP support (1), using screws (2), washers (3), and nuts (4).

4.

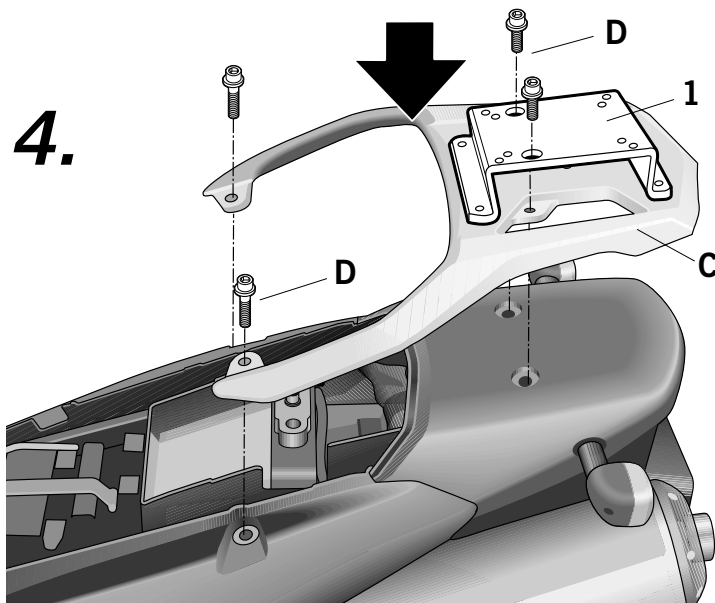

Attach the original carrier (C) together with the KIT TOP (1) using screws (D)

Attach seat (B).

5.

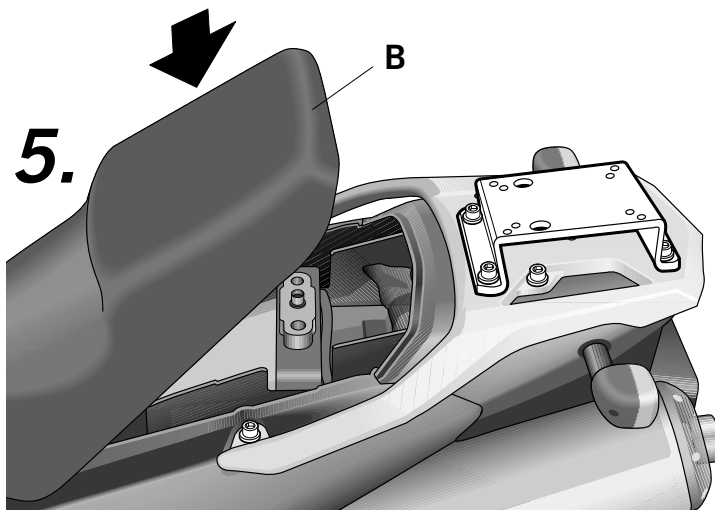

PARTE:

Pos.	Ref.	Cant.		
1	260829	1		KIT TOP
2	304081	4		Tornillo M8 x 20 DIN 7380 - Screw - Vis - Schraube - Vite
3	303020	8		Arandela Ø8 - Washer - Rondelle - Scheibe - Rondella
4	302024	4		Tuerca M8 - Nuts - Ecrou - Schraubenmutter - Dado