

**Proper kit assembly:** do not tighten the screws until ascertaining that the kit is properly positioned and aligned. **Note:** If you are assembling the Top Kit base (SOSV69ST), and the Full Kit base (SOSV69SF) of your motorcycle has already been assembled, dismantle the Full Kit base and first assemble the Top Kit base.

**1.**

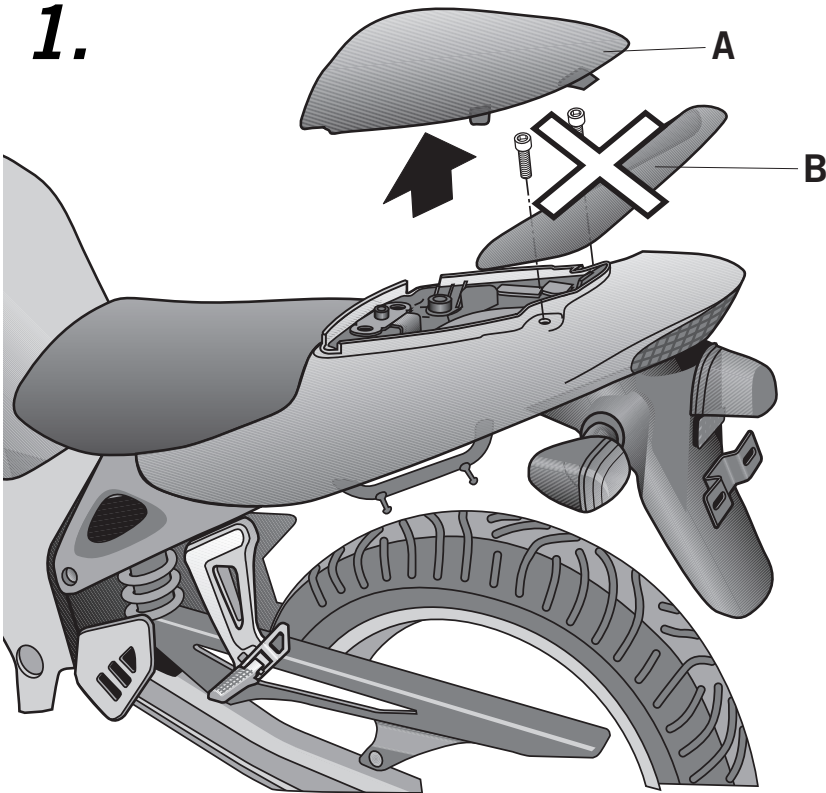

Dismantle rear seat (A).  
 Dismantle and remove handgrip (B) with its screws.

**2.**

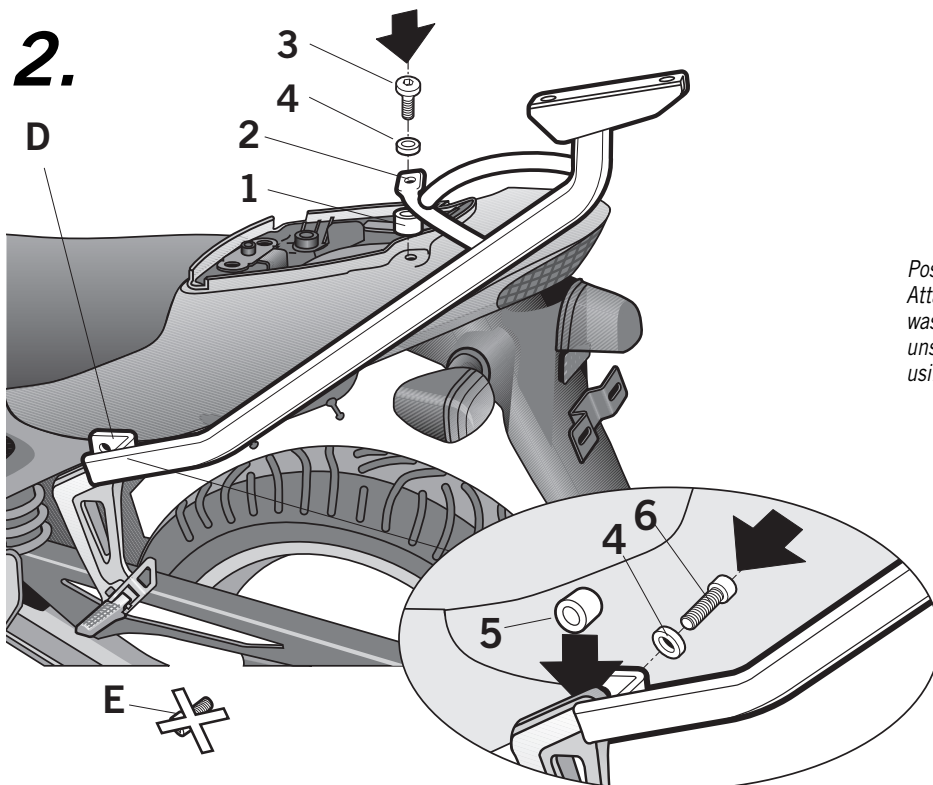



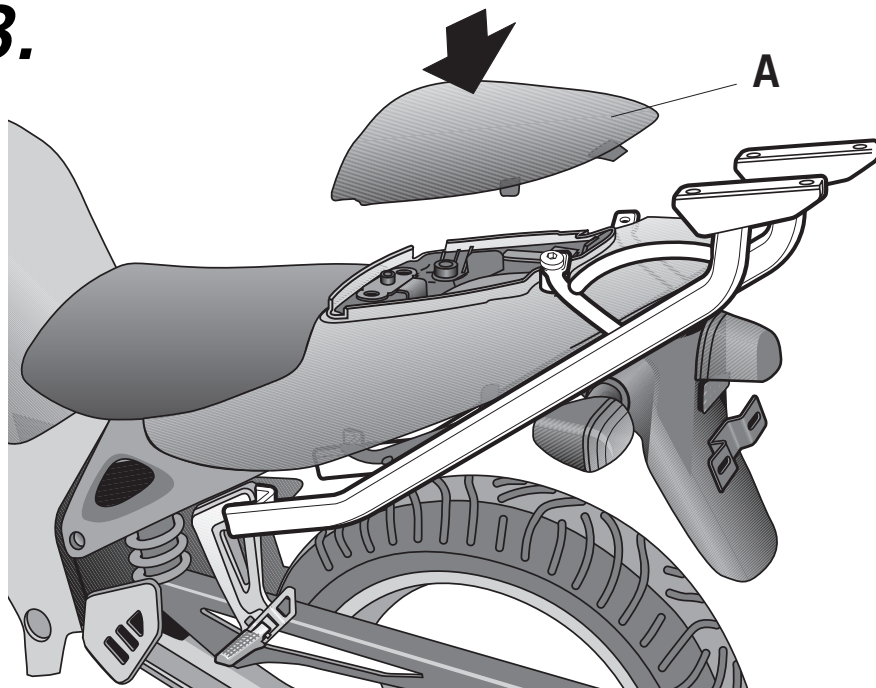

Position spacers (1). Position KIT TOP  
 Attach the assembly with screws (3) and washers (4). Where the footrest is attached (D) unscrew and remove screw (E). Attach this area using spacer (5), washers (4) and screws (6).

**3.**

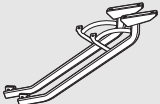

Attach rear seat (A).

**PARTS :**

Pos.	Ref.		Cant.	
1	260740		2	Ø20 x Ø11 x 11 - Distancers
2	260679		1	Right top kit support
	260680		1	Left top kit support
3	304039		2	M8 x 40 DIN 7380 - Screw
4	303020		4	Ø8 - Washer
5	260686		2	Ø16 x Ø9 x 8 - Distancers
6	304053		2	M8 x 30 DIN 7380 - Screw

# 1. Montaje parrilla D1B8PA

Fig. A

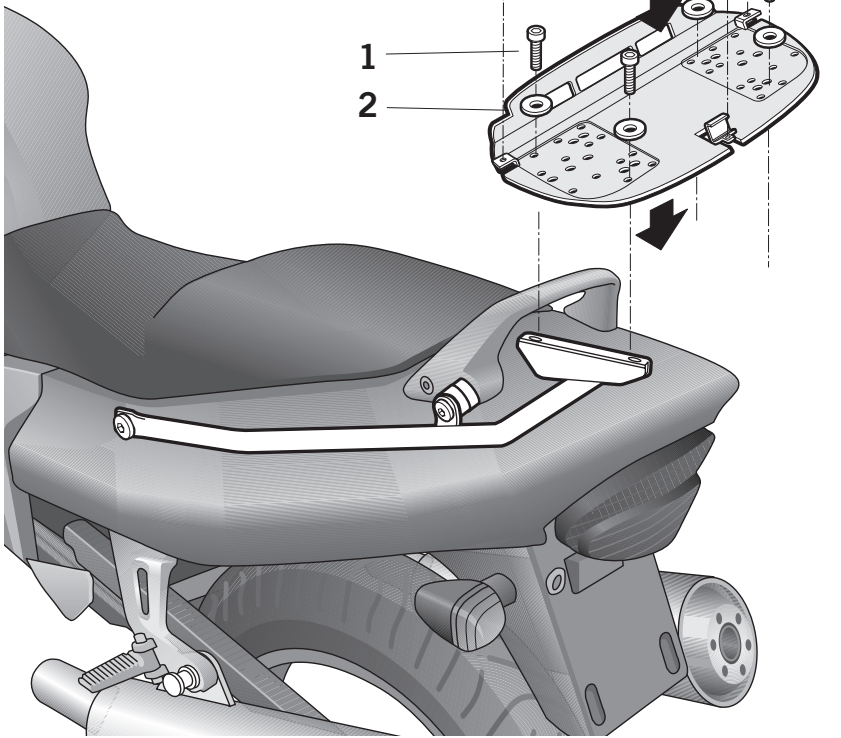



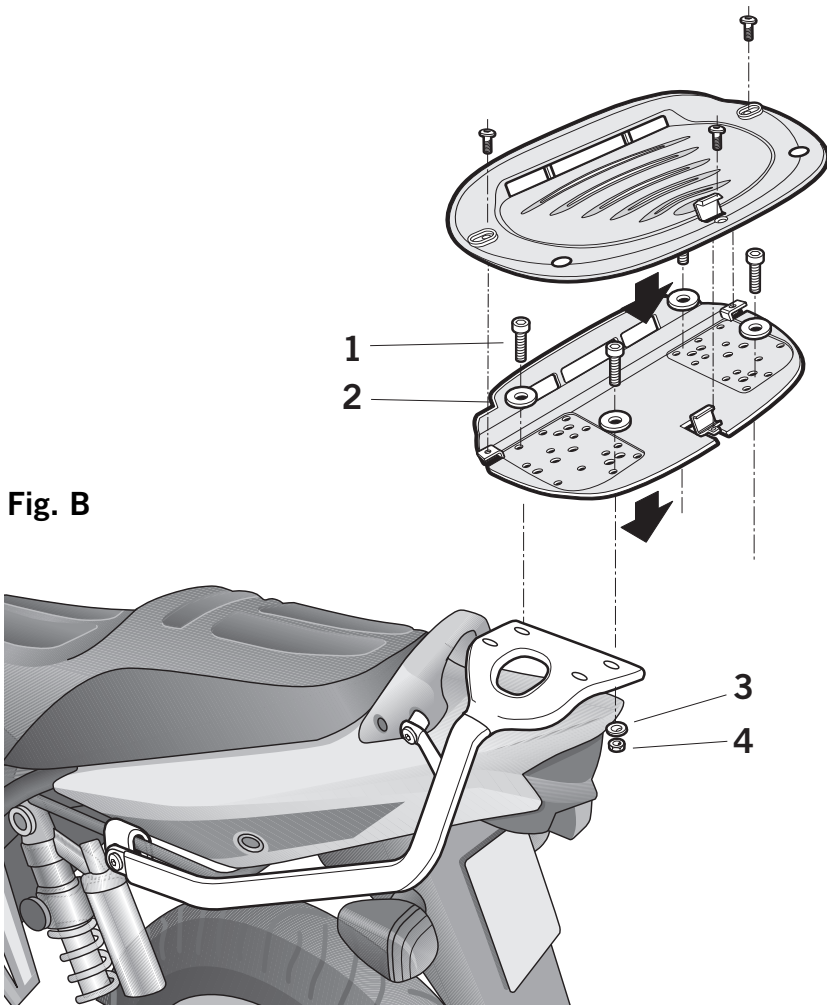

**Fig. A:** Fit the grille plate Top Case bottom rack on the Top kit support arms and secure it with the screws (1) and the washers (2).

**Fig. B:** Fit the grille plate Top Case bottom rack on the Top kit support arms and secure it with the screws (1), the washers (2) and (3) and the screws (4).

Fig. B



PARTS :

Pos.		Ref.	Cant.
1		304081 (M8x20 7380)	4
2		303018 (Ø8 ESP)	4
3		303020 (Ø8)	4
4		302024 (M8)	4

PARRILLA D1B8PA



SHAD puts everything within reach.

Discover other luggage systems & saddlebags on our website.