

Proper kit assembly: Do not fully tighten the screws until it is ensured that the KIT is correctly attached and aligned. When attaching KIT TOP supports (SOGS51ST) and your bike already has KIT FULL (SOGS51SF) assembled, dismantle the KIT FULL handgrip support. Remove spacers (5) included in this KIT TOP.

1.

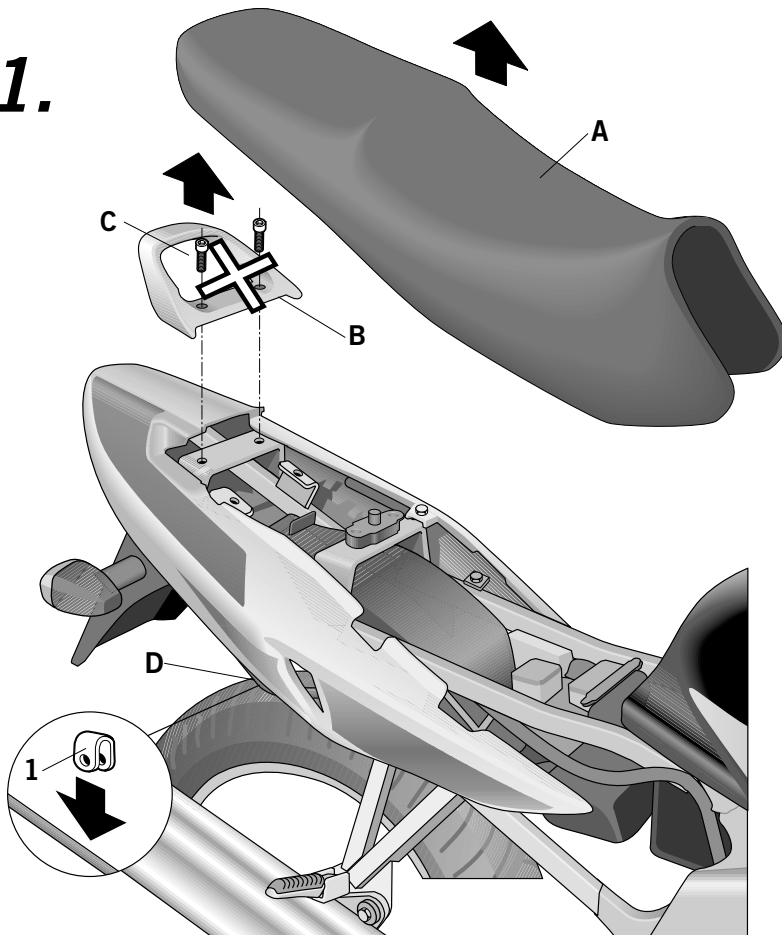

Dismantle seat (A).
Dismantle and remove handgrip (B) using and removing screws (C).
Attach bridles (1) onto the chassis tube, side area (D).

2.

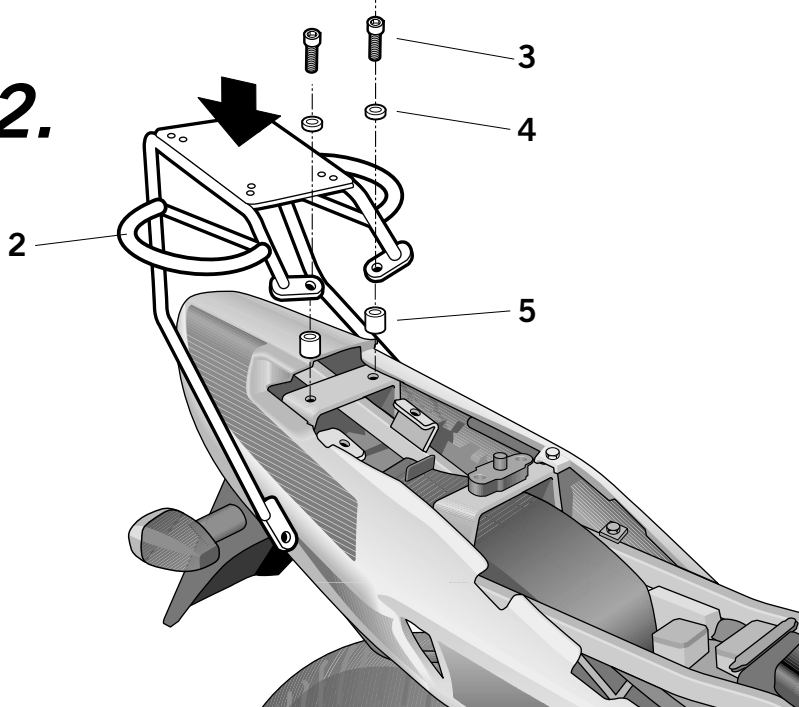

Attach KIT TOP support (2) in the handgrip area, using screws (3), washers (4) and spacers (5).

SUZUKI GS 500 '01
KIT TOPMASTER
SOGS51ST



SHAD

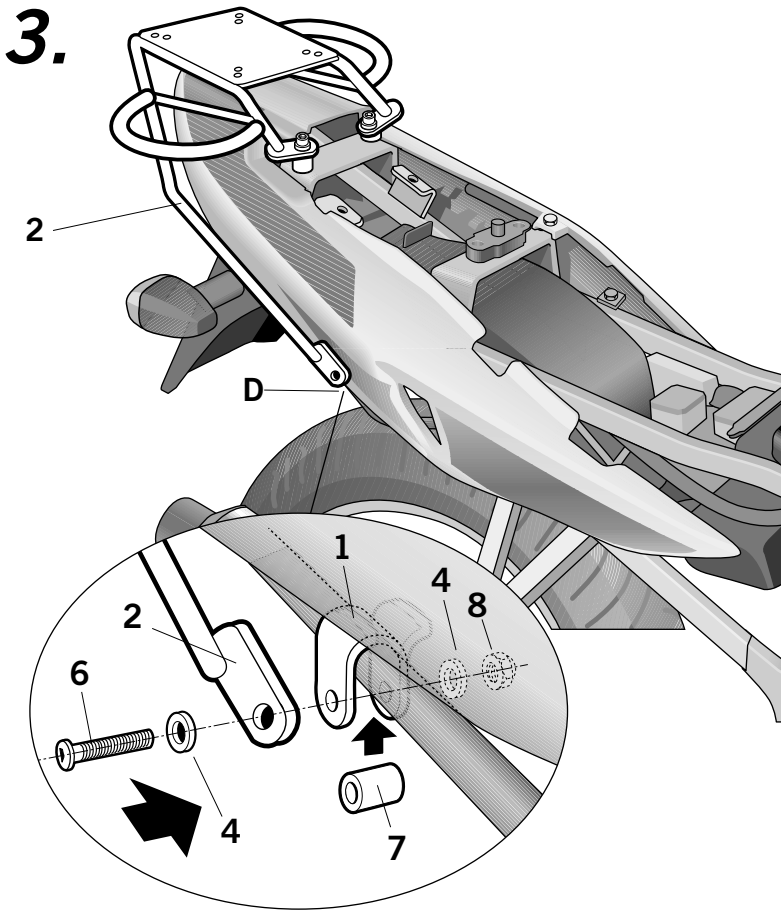

And in the chassis tube area using bridles (1), screws (6), washers (4), spacers (7) and nuts (8).

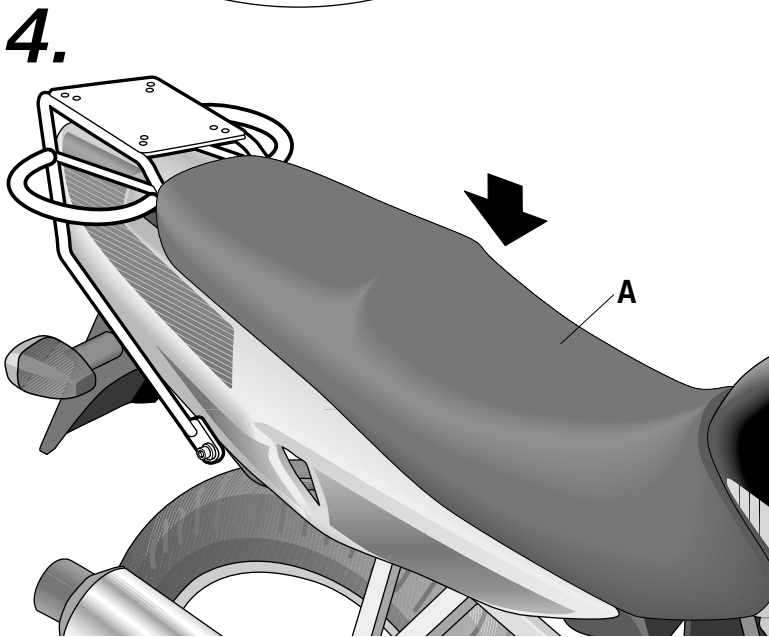

Attach seat (A).

PARTS:

Pos.	Ref.		Cant.	
1	260018		2	Big clamps
2	260823		1	KIT TOP
3	304053		2	M8 x 30 DIN 7380 - Screw
4	303020		6	Ø8 - Washer
5	260648		2	Ø16 Ø9 x 5 - Spacer
6	304039		2	M8 x 40 DIN 7380 - Screw
7	260225		2	Ø12 x 15 - Case
8	302024		2	M8 - Nuts