

Advice for correct fitting of the kit: Do not fully tighten the screws until it is ensured that the KIT is correctly attached and aligned.

1.

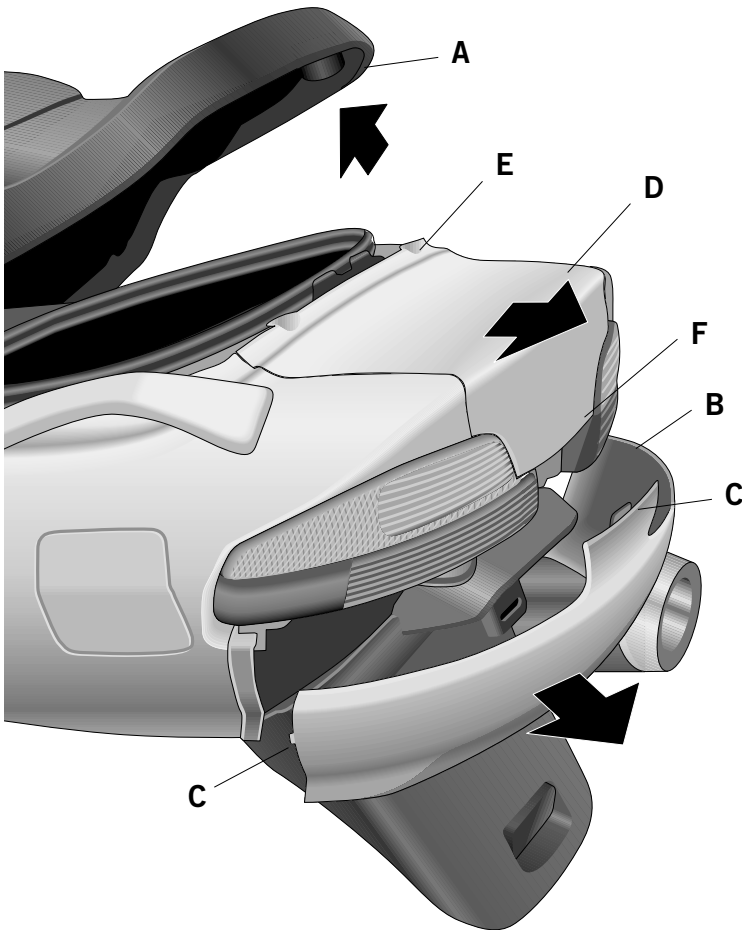

Open the seat (A).
Disassemble the lower back body (B) by means of the clips (C). A light pulling downwards will be necessary to disassemble it.
(Note: execute carefully the disassembly of the body parts to avoid possible breaks).
Disassemble the upper back body (D) by means of the clips (E) and (F). A light pulling backwards will be necessary to disassemble it.

2.

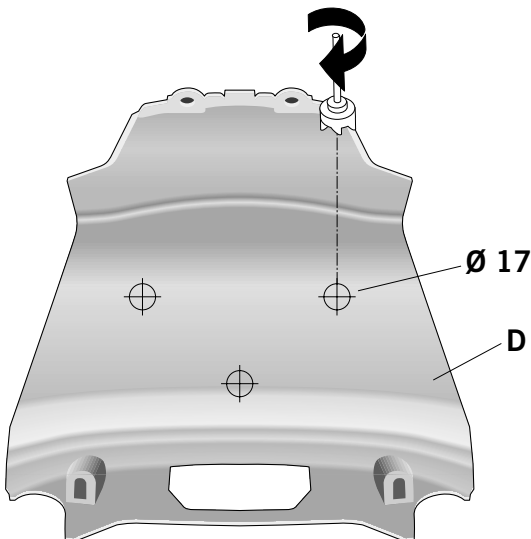

Make three holes Ø17 in the indicated points of the inner side of the upper back body (D).

SUZUKI BURGMAN 650 '02
SOBR62ST
KIT TOPMASTER



SHAD

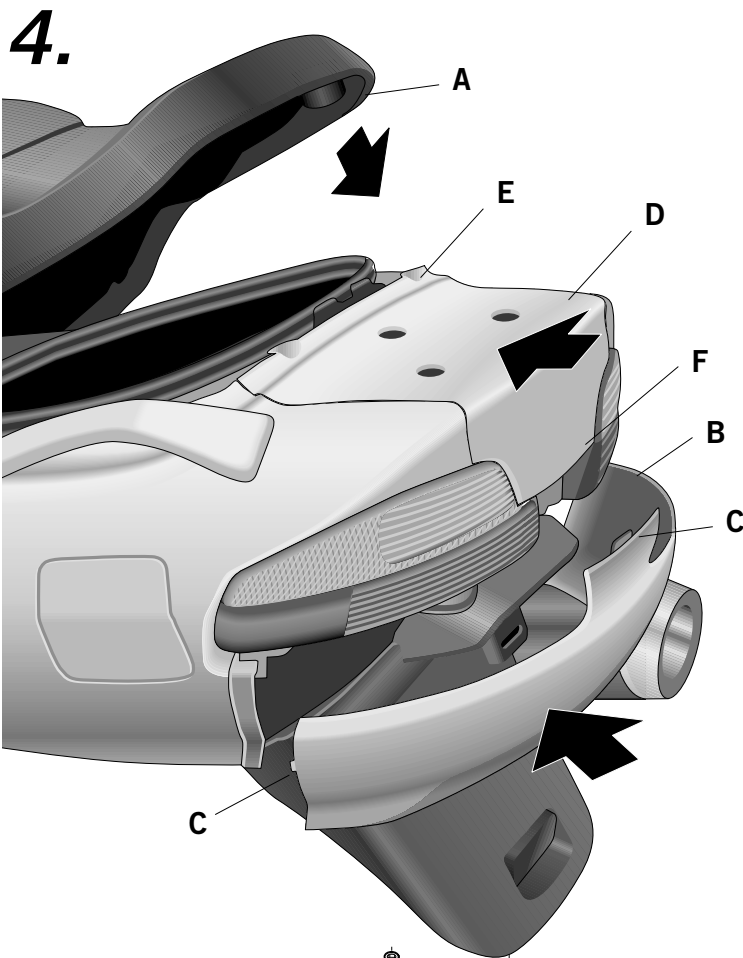

Assemble the lower (B) and the upper (D) back body parts, by means of the clips (C - E - F).
(Note: execute carefully the disassembly of the body parts to avoid possible breaks).
Close the seat (A).

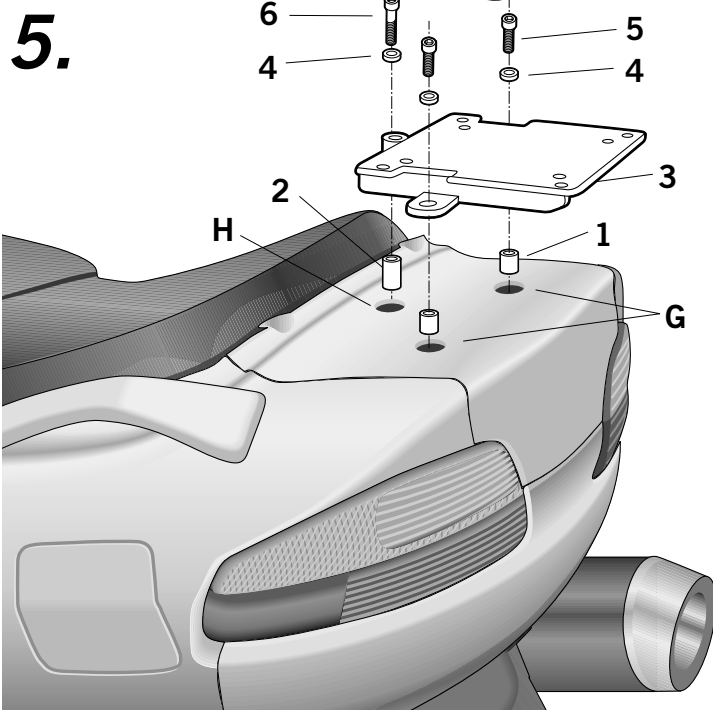

Place the clamps (1) in zone (G) and in zone (H) the clamp (2).
Place the KIT TOP support (3) and assemble it in zone (G) by means of the clamps (1), washers (4) and screws (5), and in zone (H) by means of the clamp (2), the washer (4) and the screw (6).

PARTS :

Pos.	Ref.		Cant.	
1	260800		2	ø16 x 32 - Spacer
2	260801		1	ø16 x 37 - Spacer
3	260853		1	KIT TOP
4	303020		3	ø8 - Washer
5	304169		2	M8 x 50 DIN 7380 - Screw
6	304173		1	M8 x 75 DIN 7380 - Screw