

1.

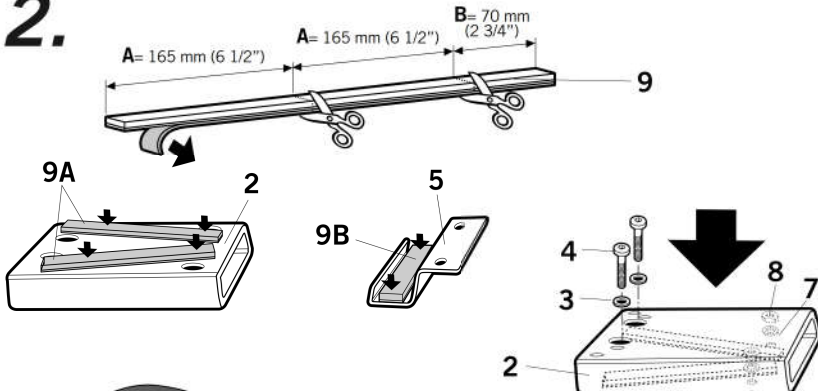

(GB) Dismantle and put aside the rubber cover (A) of the back handle (B). Dismantle and put aside in area (C) the screws (D) and loosen in area (E) the screws (F).

2.



(GB) Place the distance pieces (1) in area (C). Assemble the KIT TOPMASTER (2), in area (C) using the distance piece (1), the washers (3) and the screws (4), and in front area (G), using the cover flange (5), the screws (6), the washers (7) and the nuts (8). Tighten up again in area (E) the screws (F).

3.



PARTS

Pos.	Ref.		Cant.	
1	260596		2	Ø16-Ø9 x 20 - Spacer
2	260458		1	KIT TOPMASTER
3	303020		2	Ø8 - Washer
4	304114		2	M8 x 100 DIN 912 - Screw
5	260459		1	Cover flange
6	304052		2	M6 x 20 DIN 7380 - Screw
7	303000		4	Ø6 - Washer
8	302021		2	Self-blocking Nut M6
9	400253		0,4 m	Foam layer

KYMCO XCITING 500 '05
K0XC55ST
KIT TOPMASTER

SHAD

Discover other luggage systems & saddlebags on our website.