

**GB** Advice for correct fitting of the kit: Do not fully tighten the screws until it is ensured that the KIT is correctly attached and aligned.

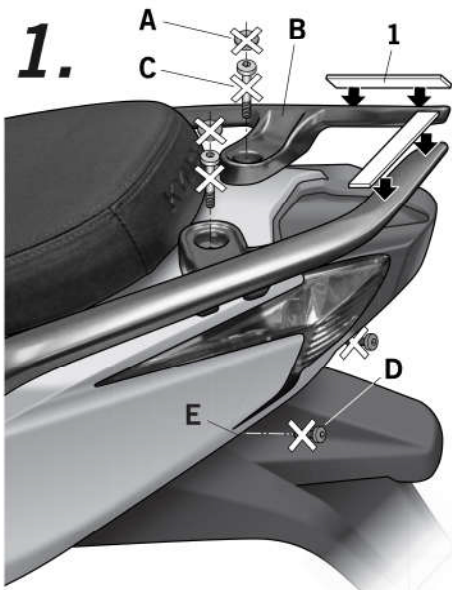

**GB** Disassembly and remove plastic covers (A) from the rear handle (B) as well as the screws (C) that must be removed too. Disassembly and remove the screws (D) from the rear mudguard, area (E). Put the foam layer (1) in the original luggage rack, so as to protect the contact area.

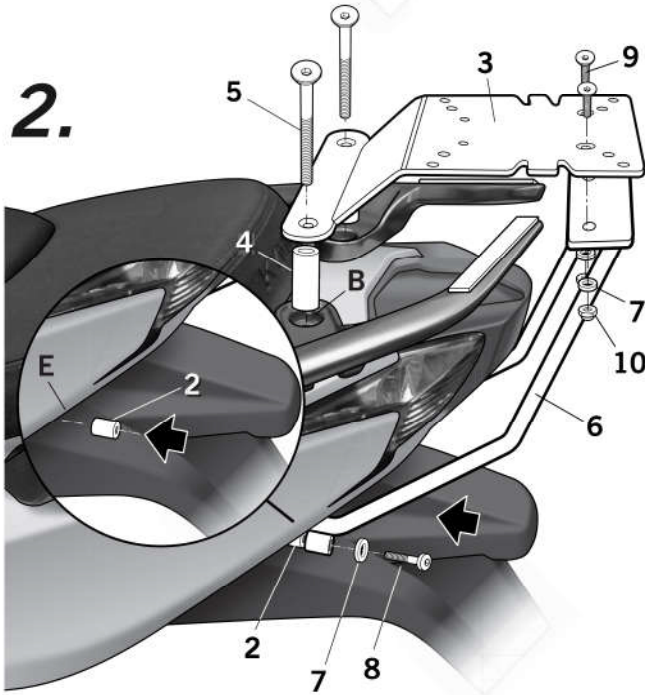

**GB** Place the threaded spacers M6 (2) in the area (E). Assemble the KIT TOPMASTER (3) to the rear handle (B), using the spacers (4) and the screws (5). And in the area (E), by means of threaded spacers M6 (2), washers (7) and screws (8). Assemble the KIT TOP (3) together with rib support (6), by means of the screws (9), the washers (7) and the nuts (10).

**PARTS**

Pos.	Ref.	Cant.	
1	400253	2	80 x12 x 3 - Foam layer
2	261499	2	Ø16 M6 x 30 - Spacer
3	261508	1	KIT TOPMASTER
4	261525	2	Ø16 Ø9 x 56 - Spacer
5	304330	2	M8 x 110 DIN 7991 - Screw
6	261509	1	Rib support
7	303000	4	Ø6 Washer
8	304037	2	M6 x 35 DIN 912 - Screw
9	304091	2	M6 x 20 DIN 7991 - Screw
10	302021	2	Self-blocking Nut M6

**KYMCO XCITING 400i '13**  
K0XC42ST  
**KIT TOPMASTER**

**SHAD**

Discover other luggage systems & saddlebags on our website.