



ROYAL 
 **PURPLE**™

CONSUMER PRODUCT CATALOG



2015 GTD CHAMPIONS

**#63 SCUDERIA
CORSA**

MOTOR OILS



🔹 API-Licensed Motor Oil	6 – 7
🗑️ Oil Filter	8 – 9
🔹 HMX - High Mileage Motor Oil	10
🔹 HPS – High Performance Street Oil	12 – 13
🔹 Max Cycle - Motorcycle Oil	14 – 15
🔹 HPM - High Performance Marine Oil	16
🔹 Break-In Oil	17
🔹 Snow 2-C Oil	18
🔹 HP 2-C (2-Cycle) Oil	19

RACING PRODUCTS



🔹 XPR – Extreme Performance Racing Oil	22 – 23
🔹 Nitro Plus Racing Oil	24
🗑️ Racing ATF	25

TRANSMISSION FLUIDS



🗑️ Max ATF	28
🌐 Synchronax	29

GEAR OILS



⚙️ Max Gear	32
⚙️ HPM – High Performance Marine Gear Lube	33

PERFORMANCE ADDITIVES



🗑️ Max-Clean	36
🗑️ Max-Atomizer	37
🗑️ Max-Tane	38
🗑️ Max-Boost	39
🗑️ Royal Flush	40
🗑️ Purple Ice	41

SPECIALTY LUBRICANTS



✖️ Max EZ	46
✖️ Max-Tuff	47
✖️ Max-Chain	48
✖️ Maxfilm	49
✖️ Synthetic Gun Oil	50
✖️ Synfilm Recip. 100	51
✖️ Ultra-Performance Grease	52

FLEET LUBRICANTS



🔹 Duralec Products	54 – 55
--------------------	---------

REFERENCE

Frequently Asked Questions	56 – 63
----------------------------	---------

PRODUCT RECOMMENDATIONS

General Applications	64 – 65
High Performance Applications	66 – 67
Transmission Lubricant Cross Reference	68 – 71
Part Numbers	72 – 74
Oil Filter Cross Reference	75

ROYAL PURPLE GEAR

Point-of-Purchase Materials	76
-----------------------------	----

LUBRICANT KEY



MOTOR OIL



OIL FILTER



GEAR OIL



AUTOMATIC
TRANS FLUID



MANUAL TRANS
FLUID



PERFORMANCE
ADDITIVES



SPECIALTY
LUBRICANTS

ABOUT ROYAL PURPLE



THE BIRTH OF A NEW LUBRICANT TECHNOLOGY

Royal Purple was founded as an industrial lubricants company by John Williams, a pioneer in developing synthetic lubricants as far back as the 1950's. He continued pursuing his passion for lubrication by serving as a consultant to numerous companies after his retirement in the 1980's.

In 1986, an oil production company asked Williams to solve chronic bearing failures in their large compressors. He found that there was not a lubricant available that could handle the extreme demands of the equipment. He put his extensive lubrication background to work in developing a new lubrication technology.

Williams developed a new additive technology that fortified lubricants with unusually high film strength capable of protecting bearings under extreme loads. This unique technology also had exceptional oxidation stability for long oil life. It provided outstanding protection against rust and corrosion in wet and high temperature applications, cleaned equipment and prevented varnishing and sludge build-up.

The new lubricant easily solved the company's equipment problems. The plant manager said it was so superior to anything he had tried before that it should not look like other lubricants. Williams elected to make the lubricant purple. That lubricant became the cornerstone of Royal Purple's product line. Williams decided to name the company Royal Purple since historically the color purple was so expensive to produce that only royalty used the color.

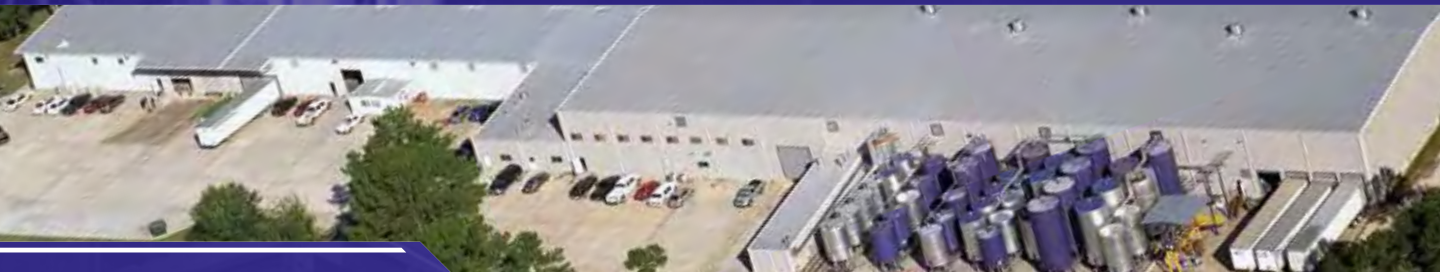

THE COMPANY EVOLVES

Industrial customers initially tried Royal Purple on the most demanding and problem equipment. Customers could easily explain the rationale for switching lubricants because no other products performed as well. Over time, industrial customers were able to document the energy and maintenance cost savings to justify upgrading their entire plants to Royal Purple industrial lubricants.

Along the way, Royal Purple began formulating racing lubricants at the request of many industrial customers who were also part-time racers. Racers noticed that Royal Purple not only dramatically reduced wear, but also maximized horsepower and torque. Demand for Royal Purple racing oils rapidly spread throughout all forms of racing.

The formulation of racing oils laid the foundation for the development of super-premium motor oils for consumer use. Royal Purple consumer motor oils and other automotive products were introduced through national automotive parts retailers beginning in 2003. There are now nearly 25,000 retailer locations in the US selling Royal Purple consumer products.

Today, Royal Purple is widely recognized as both a super-premium line of consumer automotive products and as a leading primary lubricants supplier to industrial end markets competing head-to-head with the largest oil companies. Royal Purple continues to grow in the US and internationally. Royal Purple was acquired in 2012 by Calumet Specialty Products Partners (CLMT), a leading refiner and processor of specialty hydrocarbon products headquartered in Indianapolis, IN.





**ADVANCED TECHNOLOGY CREATES
ADVANCED PRODUCTS**

Synerlec additive technology is Royal Purple’s most versatile additive technology and the cornerstone of our product line. Synerlec enables our products to significantly outperform ordinary synthetic and conventional lubricants. This proprietary additive technology improves our products on a molecular level, by creating high-strength ionic bonds with metallic surfaces that allow our lubricants to react to sustained heat and pressure with increased film strength and lubricity.

**HIGH FILM STRENGTH
IMPROVES PERFORMANCE**

The film strength of a lubricant is its inherent ability to maintain a protective oil film, resisting the effects of load, speed and temperature. When the oil film is breached, metal to metal contact occurs, which results in greater friction and heat generation and accelerated wear. Royal Purple’s Synerlec-enhanced lubricants provide dramatically increased oil film strength that is 3 to 4 times as strong as film provided by any other comparable lubricant. This dramatically improved film strength results in less metal to metal contact, less short and long-term wear, lower operating temperatures and increased piston ring seal in engines. Royal Purple’s Synerlec-enhanced lubricants respond to increased pressure with increased oil film strength, where other lubricants have been displaced. Take a look at the following photos:

BEARING COMPARISON

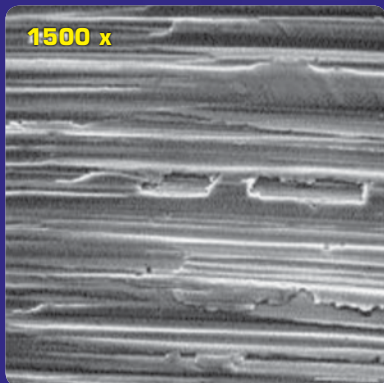

A new bearing surface appears smooth until magnified 1500X.

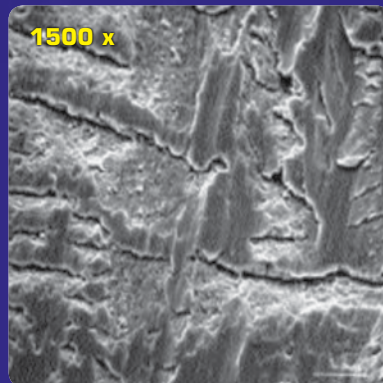

The bearing is scuffed after using a leading synthetic motor oil.

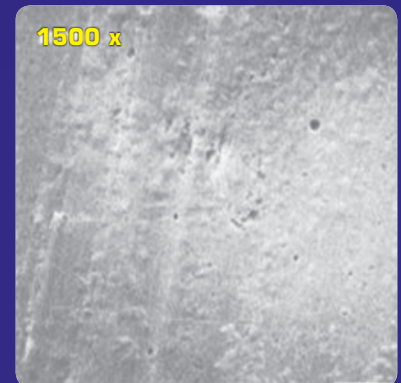

The bearing is visibly smoother after using Royal Purple HPS.

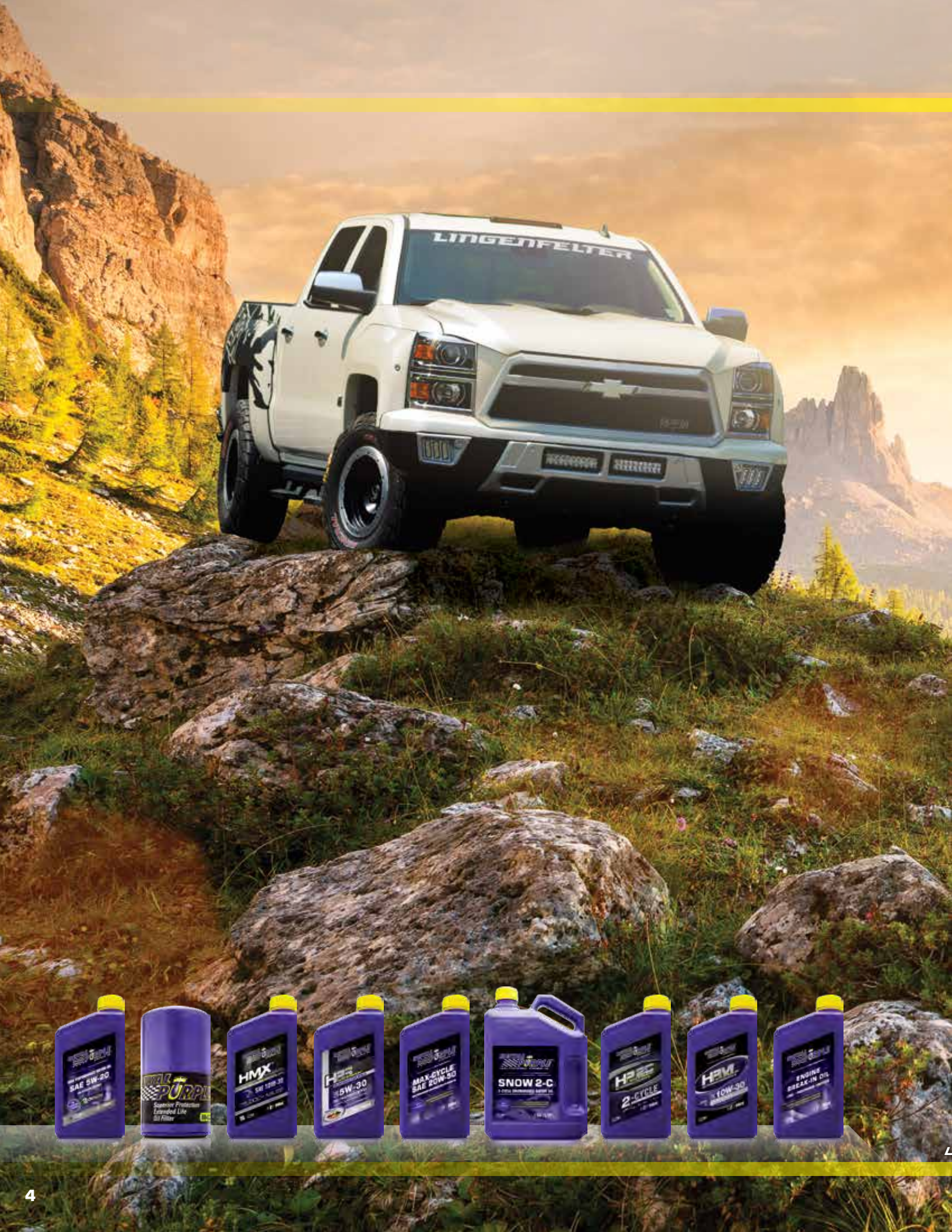

MOTOR OILS

Royal Purple's premium synthetic motor oils provide superior performance and protection for a variety of vehicle applications. Our motor oil line covers gasoline and diesel vehicles under warranty; high performance and out of warranty; high mileage over 75,000 miles and racing oils.

INGENFELTER PERFORMANCE ENGINEERING USES ROYAL PURPLE EXCLUSIVELY

IMAGE - Lingenfelter

API-LICENSED MOTOR OIL



MULTI-GRADE OILS
0W-20, 0W-40, 5W-20, 5W-30, 5W-40,
10W-30, 10W-40, DURALEC 15W-40⁸, 20W-50

*See additional Duralec products on pages 54 – 55

Royal Purple meets or exceeds ILSAC GF-5, dexos1™* and other OEM engine oil specifications in critical lubrication performance:

BETTER WEAR PROTECTION

Enhanced additive technology prevents metal-to-metal contact beyond both dexos1™* and ILSAC GF-5 specs

INCREASED FUEL EFFICIENCY

A low coefficient of friction results in optimized fuel efficiency (the fuel economy of our 5W-30 meets the fuel economy requirements of a 5W-20 oil)

BETTER PROTECTION OF THE EXPENSIVE CATALYTIC EMISSION SYSTEM

Patented anti-wear additive chemistry minimizes the harmful effects exhaust gases pose to the catalyst

IMPROVED COMPATIBILITY WITH FUELS CONTAINING ETHANOL

Patented additive technology prevents the white sludge and lubrication starvation that can occur with higher concentration gasoline-ethanol blends

SUPERIOR CORROSION PROTECTION

No rust observed in standard industry testing

*dexos1™ is a registered trademark of the General Motors Corporation.

API-LICENSED MULTI-GRADE OILS — TYPICAL PROPERTIES*

ASTM TESTS		SAE GRADE / API SERVICE								
		0W-20 ^{1,8}	0W-40 ⁴	5W-20 ^{1,7}	5W-30 ^{1,5}	5W-40 ⁴	10W-30 ^{1,6}	10W-40	15W-40 ^{2,3}	20W-50
		SN	SM	SN	SN	SM	SN	SN	CJ-4/SN	SN
D445	Viscosity									
	cSt @ 40°C	42.58	79.9	48.58	60.62	93.7	65.27	83.67	105	181.4
	cSt @ 100°C	8.37	14.3	8.5	10.42	15.7	10.75	13.36	14.8	20.23
D2270	Viscosity Index	177	182	153	162	179	155	162	146	130
D4683	HTHS	2.58	3.58	2.66	3.07	3.91	3.18	3.67	4.22	5.00
D4684	Pumping Viscosities									
	cP @ -40°C	34,200	20,000	—	—	—	—	—	—	—
	cP @ -35°C	—	—	18,400	25,200	13,040	—	—	—	—
	cP @ -30°C	—	—	—	—	—	12,000	15,000	—	—
	cP @ -25°C	—	—	—	—	—	—	—	15,000	—
	cP @ -20°C	—	—	—	—	—	—	—	—	27,700
D92	Flash Point °F	420	465	435	420	425	425	425	430	425

* Properties are typical and may vary.

1 API SN Resource Conserving and ILSAC GF-5.

2 For use in both gasoline and diesel engines.

3 15W-40 meets Cummins CES 20081, DDC Powerguard 93K218, Mack E0-0 Premium Plus, Renault VI RLD-3 and Volvo VDS-4 engine oil requirements.

4 0W-40 and 5W-40 meets and/or exceeds European specs ACEA A3/B3-04 warranty requirements and is recommended for passenger car gasoline and light duty diesel engines.

5 5W-30 meets Chrysler FCA US MS-6395T, Ford WSS-M2C946-A and GM 6094M specifications and dexos1™* warranty requirements for gasoline engines.

6 10W-30 meets Chrysler FCA US MS-6395T and GM6094M specification for gasoline engines.

7 5W-20 meets Chrysler FCA US MS-6395T, Ford WSS-M2C945-A and GM6094M specifications and dexos1™* warranty requirements for gasoline engines.

8 0W-20 meets Chrysler FCA US MS-6395T specification and dexos1™* warranty requirements for gasoline engines.

PART NUMBERS

MULTI-GRADE

0W-20	55-Gal. Drum	55020
	5-Gal. Pail	05020
	5-Qt. Bottle	51020
	1-Qt. Bottle	01020
0W-40	1-Qt. Bottle	11484
5W-20	55-Gal. Drum	55520
	5-Gal. Pail	05520
	5-Qt. Bottle	51520
	1-Qt. Bottle	01520
5W-30	55-Gal. Drum	55530
	5-Gal. Pail	05530
	5-Qt. Bottle	51530
	1-Qt. Bottle	01530
5W-40	55-Gal. Drum	55540
	5-Gal. Pail	05540
	1-Qt. Bottle	01540
10W-30	55-Gal. Drum	55130
	5-Gal. Pail	05130
	5-Qt. Bottle	51130
	1-Qt. Bottle	01130
10W-40	55-Gal. Drum	55140
	5-Gal. Pail	05140
	1-Qt. Bottle	01140
15W-40	55-Gal. Drum	55154
	5-Gal. Pail	05154
	1-Gal. Bottle	04154
	1-Qt. Bottle	01154
20W-50	55-Gal. Drum	55250
	5-Gal. Pail	05250
	1-Qt. Bottle	01250



STRAIGHT-GRADE

SAE 30	55-Gal. Drum	55030
	5-Gal. Pail	05030
	1-Qt. Bottle	01030
SAE 40	55-Gal. Drum	55040
	5-Gal. Pail	05040
	1-Qt. Bottle	01040
SAE 50	55-Gal. Drum	55050
	5-Gal. Pail	05050
	1-Qt. Bottle	01050

API-LICENSED STRAIGHT-GRADE OILS TYPICAL PROPERTIES*

ASTM TESTS		SAE GRADE / API SERVICE		
		30 / SJ	40 / SJ	50 / SJ
D-445	Viscosity			
	cSt @ 40°C	79.0	121.0	182.0
	cSt @ 100°C	10.6	14.2	18.6
	cSt @ 100°F	408	631	955
	cSt @ 210°F	63	74	92
D-2270	Viscosity Index	119	113	113
D-92	Flash Point °F	445	455	435

* Properties are typical and may vary.



EXTENDED LIFE OIL FILTERS



PERFORMANCE ADVANTAGES

1 SHELL

A thick, heavy exterior shell provides extra security against puncture from road debris.

2 FILTER ELEMENT

100% synthetic filtration media with steel screen backing provides superior filtration, low restriction to flow and high particulate capacity.

3 STEEL BACKPLATE

Heavy gauge steel provides up to twice the burst strength of ordinary filters.

4 METAL END-CAPS

Provides rigid support for filtration media enhancing internal sealing.

5 METAL CENTER TUBE

Metal construction prevents filter element collapse.

6 BYPASS VALVE

Ensures oil flow in situations of excessive filter element flow restriction.

7 SILICONE ANTI-DRAINBACK VALVE

Prevents dry starts by eliminating oil drain back during shutdown. Silicone outperforms and outlasts standard nitrile rubber in both extreme cold and hot oil temperatures.

8 GASKET

Premium nitrile rubber and special lubricity compounds reduce torque during installation and removal.

Royal Purple premium oil filters provide superior filtration and flow, outstanding particulate capacity and heavy duty construction for cleaner oil and longer filter life.

EACH FILTER FEATURES

- 100% synthetic micro-glass media that catches 99% of particles 25 microns and larger, and 80% of particles 10 microns and larger
- High-performance silicone anti-drain back valve that prevents dry starts, even in extreme conditions
- Extra heavy-duty rubber base gasket that ensures a leak-free seal
- An ultra-strength filter housing endures higher burst strength than conventional filters

FILTER MEDIA COMPARISON

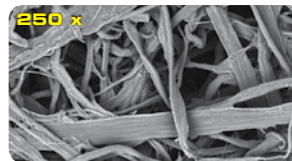

Magnification of 250x, photo shows conventional cellulose filtration fibers. The spaces allow larger particles to pass through to your engine.

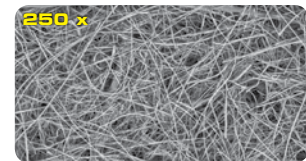

Royal Purple's state-of-the-art synthetic filtration media provides greater filtration efficiency and particulate capacity while minimizing flow restriction.

AVERAGE BETA RATING BASED ON ISO 4548-12 MULTI-PASS TEST METHODS:

B100 = 25 (at 25 or greater micron, media is 99% efficient.)

B75 = 20 (at 20 or greater micron, media is 98.7% efficient. Also considered absolute rating.)

B5 = 10 (which means at 10 micron or greater, media is 80% efficient.)



PRINCIPAL APPLICATIONS — OIL FILTERS

PART NUMBER	PRINCIPAL APPLICATION
10-2808	Honda (1983 – 09), Hyundai (1986 – 14), Isuzu (1984 – 04), Kia (2001 – 15), Mazda (1972 – 91), Mitsubishi (1987 – 14), Subaru (1992 – 96, 01 – 14) (Honda 15400-PR3-014, Hyundai 26300-35502; Isuzu 8971406660; Mitsubishi TMD-352626; Subaru 15208-AA030)
10-2835	Chrysler, Dodge (1995 – 11), Mazda (2011 – 14) Ford Focus, Escape (2003 – 14), Fusion (2010 – 13), Lexus, Toyota (1988 – 14), Saturn (1991 – 02) Harley-Davidson Motorcycles (1987 – 14), Buell Motorcycles (1987 – 02) (Harley-Davidson 63796-77A) Chrome Filter
10-2840	GEO/Chevrolet Prizm (1989-05), Scion (2004-14), Suzuki (1996-13), Toyota (1988-14)
10-2867	Chrysler Products (1991-98, 01-05), Ford Probe (1989-97), Honda (2001-14), Infiniti (1995-14), Mitsubishi (1992-14), Mazda (1983-02, 09-11), Nissan (1995-14) (Nissan 15208-9E000; Mitsubishi MZ690072)
10-2876	Subaru (1990-04) (Subaru 15208-AA-021, 15208-AA-020) Hyundai, Kia (1994-10), Infiniti, Nissan (1995-14) Mazda (1990-08, 2011-15), Subaru (2004-14) (Mazda B6Y1-14-302; Subaru 15208-KA010)
10-3244	Buick Regal, Lacrosse (2011-14), Chevrolet 4 cyl. 2.4L (2002-14), Pontiac 4 cyl. 2.4L (2002-10), Saturn 4 cyl. (2000-10), Saab 93, 93X (2003-11)
10-44	American Motors, Jeep (1983-86), GM Products (1996-12)
10-454	Chevrolet & GMC V8 7.4L, 8.1L Engines (1999-09)
10-47	GM Products (1975-14), Isuzu (1989-94, 96-03)
10-48	Buick, Cadillac, Chevrolet, GMC (2007-15), Chrysler, Dodge, Jeep (2007-15) (AC PF48; GM 89017524)
20-2009	Jaguar (1997-10), Land Rover (2005-09), Lincoln (2000-06)
20-2129	Cadillac CTS V6 3.6L (2004-15), SRX V6 3.6L (2004- 11), STS V6 3.6L (2005-11), Chevrolet Camaro V6 3.6 (2010-14), Oldsmobile (1999-02), Pontiac G8 (2008-09), Saab 93 (2006-10), 95 (2011) (GM 25177917)
20-253	Chrysler, Dodge, Plymouth (1991-09), Jeep/Eagle (1991-08) (Chrysler 5281090)
20-400	Ford Contour, Escape, Focus (1998-04) (Ford F8CZ-6731-AA; Motorcraft FL2005) Chrysler Products (2002-09), Ford Products (1971-09), Jaguar X Type (2000-08), Mazda 6 (2009-13), CX9 (2007-14)
20-500	Buick Enclave, Lacrosse (2011-14) Dodge/Jeep V6 3.7L (2009-12), Ford Products V6 (2009-14)
20-51A	GM Products (1980-05), Isuzu (1997-99)
20-561	Audi (1970-06), Volkswagen (1974-14) (Volkswagen 06A-115-561B)
20-59	Cadillac (1972-11), GM Trucks (1999-12), Oldsmobile (1995-04), Pontiac (2004-10)
20-820	Ford Products (1991-15), Mazda (2000-09), Chrysler, Dodge V6 & V8 (2008-14)
20-967	Toyota V6 3.5L (2005-14), Lexus (2007-14) (Toyota 04152-31090)
30-1218	Chevrolet & GMC Pickups (1962-02), Hummer (1996-04) (AC PF1218; GM 25160561)
30-2999	Chevrolet & GMC Pickups 6.6L Diesel (2001-15) (AC PF2232)
30-8A	Chrysler Products (1959-76), Ford Products (1957-01), Mazda (1991-00), Merkur (1987-89), Toyota (1969-96)
40-2051	Ford Super Duty Pickup 6.7L (2011-15) (Ford BC3Z-6731-A)
40-780	Dodge/Ram Pickup Cummins Diesel Eng. (1989-14) (Cummins 3903964)
50-2017	Ford 6.0L, 6.4L Turbo Diesel (2003-10) (Ford 3C3Z-6731-AA)
50-2286	Ford Pickup w/Diesel Eng. (1995-03) (Ford F4TZ-6731-A; Motorcraft FL1995)



HMX[®] HIGH MILEAGE MOTOR OIL



MULTI-GRADE OILS
5W-30 & 10W-30

Royal Purple HMX is specifically formulated with robust zinc / phosphorus anti-wear additives and Royal Purple's proprietary additive technology Synerlec to minimize wear and restore lost engine performance.

HMX is chemically enhanced to revitalize hardened seals reducing oil consumption common in higher mileage engines. Stout detergents remove engine deposits and maintain cleanliness promoting engine longevity.

Royal Purple's advanced Synerlec technology provides an exceptional film strength by reducing friction for peak engine performance. Synerlec also provides outstanding oxidation resistance to safely extend oil drains, and an ionic attraction to metal components maintaining a film of oil on parts minimizing start-up wear.

PERFORMANCE ADVANTAGES

- Minimizes wear and restores lost engine performance
- Fortified with **Zinc/Phosphorus** anti-wear additive
- Extended drain intervals
- Exceptional oxidation stability
- Reduces engine deposits
- Superior corrosion protection

PLEASE NOTE: Royal Purple meets API Service SL warranty requirements for gasoline engines. API recommends SL oils for 2004 or older automobiles. Royal Purple recommends this product for any four-cycle gasoline engine with 75,000 miles (120,000 km) or more.

PART NUMBERS

5W-30	5-Qt. Bottle	11748
	1-Qt. Bottle	11744
10W-30	5-Qt. Bottle	11750
	1-Qt. Bottle	11746

HMX — TYPICAL PROPERTIES*

ASTM TESTS		SAE GRADE	
		5W-30	10W-30
D445	Viscosity		
	cSt @ 40°C	64.7	72.7
	cSt @ 100°C	11	11.5
D2270	Viscosity Index	162	153
D2896	TBN, mg KOH/g	13.4	13.3
D5293	Cold Crank Simulator		
	cP @ -30°C	5,259	—
	cP @ -25°C	—	4,193
D93	Flash Point °F	420	434

* Properties are typical and may vary.



HPS® HIGH PERFORMANCE STREET MOTOR OIL



MULTI-GRADE OILS

5W-20, 5W-30, 10W-30, 10W-40 & 20W-50

- All HPS viscosities are formulated for gasoline and diesel engine use.

Royal Purple HPS Series motor oil is specifically formulated to maximize performance and meet the demands of high performance and modified engines. HPS is recommended for vehicles no longer under manufacturer warranty and for those seeking a higher level of performance and protection.

Royal Purple HPS oils are fortified with a high level of **Zinc / Phosphorus** anti-wear additive and a generous dose of Royal Purple's proprietary Synerlec additive technology. These unique formulations enable HPS oils to outperform leading synthetic and conventional lubricants in both gasoline and diesel engines.

PERFORMANCE ADVANTAGES

- Exceptionally high film strength for dramatic reductions in engine wear and reduced engine heat to extend the life of your engine
- Improved sealing between the piston ring and cylinder wall maximizes horsepower and torque and optimizes fuel economy
- Exceptional oxidation stability extends oil life and allows for more miles driven between oil changes saving you time and money
- Advanced synthetic solvency reduces engine deposits and keeps engines clean
- **Protects valve trains using roller or flat tappet lifters** that require added protection due to high lift / high ramp rate camshafts
- Provides superior corrosion protection

BEARING COMPARISON

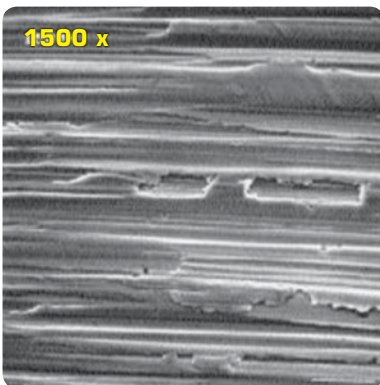

A new bearing surface appears smooth until magnified 1500X.

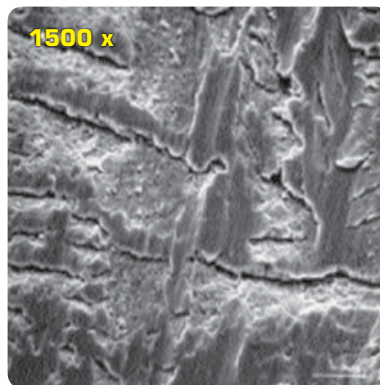

The bearing is scuffed after using a leading synthetic motor oil.

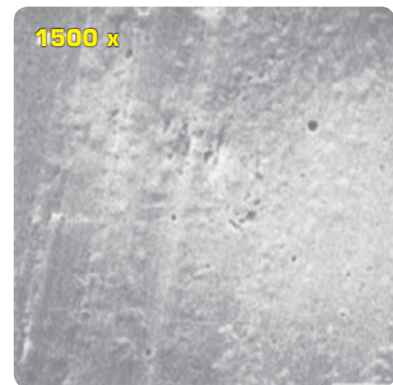

The bearing is visibly smoother after using Royal Purple HPS.

HPS® HIGH PERFORMANCE STREET MOTOR OIL

PART NUMBERS

5W-20	55-Gal. Drum	37520
	5-Gal. Pail	35520
	1-Qt. Bottle	31520
5W-30	55-Gal. Drum	37530
	5-Gal. Pail	35530
	1-Qt. Bottle	31530
10W-30	55-Gal. Drum	37130
	5-Gal. Pail	35130
	1-Qt. Bottle	31130
10W-40	55-Gal. Drum	37140
	5-Gal. Pail	35140
	1-Qt. Bottle	31140
20W-50	55-Gal. Drum	37250
	5-Gal. Pail	35250
	1-Qt. Bottle	31250



HPS — TYPICAL PROPERTIES*

ASTM TESTS		SAE GRADE				
		5W-20	5W-30	10W-30	10W-40	20W-50
D445	Viscosity					
	cSt @ 40°C	49.8	64.9	72	91.5	169.2
	cSt @ 100°C	8.8	11.1	11.4	13.6	19.9
D2270	Viscosity Index	155	167	154	161	136
D2896	TBN, mg KOH/g	11.6	11	11.3	11	11.1
D5293	Cold Crank Simulator					
	cP @ -30°C	4744	4897	—	—	—
	cP @ -25°C	—	—	4571	6391	—
	cP @ -20°C	—	—	—	—	—
	cP @ -15°C	—	—	—	—	6227
D93	Flash Point °F	424	430	434	430	434

* Properties are typical and may vary.





MULTI-GRADE OILS 10W-30, 10W-40 & 20W-50

PART NUMBERS

10W-30	1-Qt. Bottle	01314
10W-40	1-Qt. Bottle	01315
20W-50	1-Qt. Bottle	01316

Royal Purple Max-Cycle is specifically formulated to exceed the demands of highly stressed engines and transmissions. It is recommended for use in both air-cooled and liquid-cooled 4-cycle engines and is compatible with wet-clutch transmissions.

Formulated with select synthetic base oils and Royal Purple's proprietary Synerlec additive technology, Max-Cycle provides improved film strength when compared to the leading synthetic and mineral oil. Its shear stability and oxidation resistance promotes greater performance and protection.

Max-Cycle meets or exceeds API requirements and is rated JASO MA2, the highest wet clutch compatibility rating under the JASO T903:2011 Clutch Friction Test. Max-Cycle is compatible with other mineral and synthetic motor oils. No flushing is necessary prior to use.

PERFORMANCE ADVANTAGES

- Greater wear protection
- Cleaner, more efficient engines
- Superior rust / corrosion protection
- Cooler operation and less parasitic power loss

MAX-CYCLE — TYPICAL PROPERTIES*

	ASTM TESTS	SAE GRADE		
		10W-30	10W-40	20W-50
D445	Viscosity			
	cSt @ 40°C	74	92	165
	cSt @ 100°C	11.5	14	20
D2270	Viscosity Index	145	155	141
D2896	TBN, mg KOH/g	9.3	9.6	9.45
D5293	Cold Crank Simulator			
	cP @ -25°C	4948	5341	—
	cP @ -15°C	—	—	4491
D92	Flash Point °F	400	400	415
D6892	Pour Point °F	-49	-49	-26
D4683	HTHS			
	cP @ 150°C	3.44	3.95	5.05

* Properties are typical and may vary.

REDUCES HEAT

Improved combustion and reduced friction help to prevent overheating and to extend the life of the oil and the engine. In an independent test conducted on an American-made V-Twin motorcycle, engine temperatures were reduced 25°F to 44°F just by switching to Royal Purple. See graphics below:

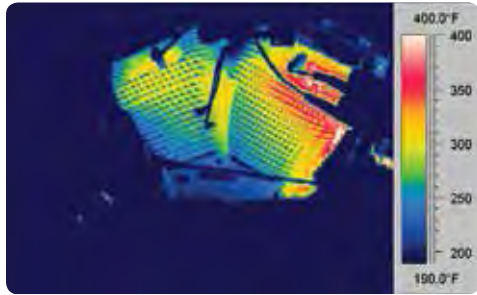

Thermal imaging results with factory synthetic oil

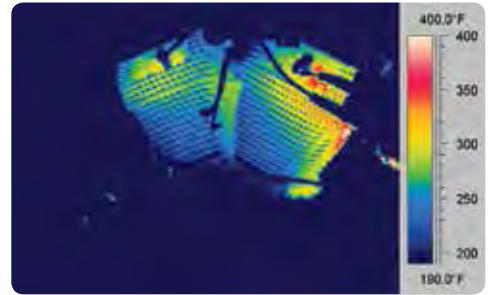

Thermal imaging results after switching to Max-Cycle[®]



HPM® HIGH PERFORMANCE MARINE MOTOR OIL



AVAILABLE VISCOSITIES: 10W-30 & 10W-40.

- 10W-30 is suitable for any 4-stroke gasoline inboard or outboard engine recommending a SAE 30, 10W-30 or other multi-viscosity 30 weight marine oil.
- 10W-40 is suitable for any 4-stroke gasoline inboard or outboard engine recommending a SAE 40, 10W-40, 15W-40, 20W-40, 25W-40 or other multi-viscosity 40 weight marine oil.

Royal Purple High Performance Marine Oil (HPM) is specifically formulated to maximize performance and provide superior protection for four-stroke marine engines. HPM oils are certified NMMA FC-W Catalyst Compatible®, and exceed stringent OEM performance and warranty requirements.

HPM motor oils provide exceptional anti-wear protection with a load-carrying capacity multiple times that of ordinary mineral or synthetic marine lubricants. It delivers cooler operating temperatures, increases engine efficiency and maximizes horsepower and torque. Royal Purple's advanced, proprietary Synerlec technology enables HPM to exceed the harsh demands of marine applications.

PERFORMANCE ADVANTAGES

- Exceptionally high film strength for dramatic reductions in engine wear and heat to extend the life of your engine
- Improved sealing between the piston ring and cylinder wall for optimized fuel economy and maximum horsepower and torque
- Exceptional oxidation stability extends oil life and allows for more hours between oil changes saving you time, money and reducing the impact on the environment
- Advanced synthetic solvency reduces engine deposits and keeps engines clean.
- Superior corrosion protection

Take a look at the following photos:

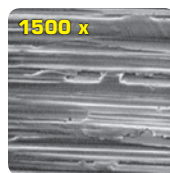

A new bearing surface appears smooth until magnified 1500X.

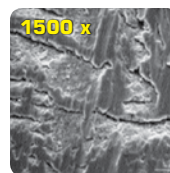

The bearing is scuffed after using a leading synthetic motor oil.

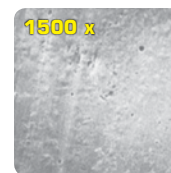

The bearing is visibly smoother after using Royal Purple HPM.

PART NUMBERS

10W-30	1-Qt. Bottle	11582
10W-40	1-Qt. Bottle	11629

HPM — TYPICAL PROPERTIES*

ASTM TESTS		SAE GRADE	
		10W-30	10W-40
D445	Viscosity		
	cSt @ 40°C	75.6	93.2
	cSt @ 100°C	11.8	14.1
D2270	Viscosity Index	150	156
D2896	TBN, mg KOH/g	7.6	7.7
D5293	Cold Crank Simulator		
	cP @ -25°C	5,193	5,515
D93	Flash Point °F	449	449

* Properties are typical and may vary.

Engine builders have grown increasingly concerned that current engine oils that are API licensed for new cars and trucks do not provide adequate wear protection for freshly built performance engines, particularly those using flat tappet camshafts and lifters. Royal Purple has addressed this issue with Royal Purple Break-In Oil.

Royal Purple Break-In Oil is formulated to provide the critical wear protection needed by the engine valve train and camshaft while allowing new piston rings to quickly seat to the engine cylinder walls. Break-In Oil combines highly refined mineral oil (preferred for engine break-in) with an advanced additive package containing elevated levels of zinc/phosphorus anti-wear additive to optimize wear protection during the sensitive engine break-in phase.

Royal Purple Break-in Oil is a fully formulated conventional 10W-30 engine oil and does not require the use of any other chemical additives. Royal Purple recommends using their high performance synthetic motor oils after engine break-in for maximum engine performance and protection.

PART NUMBERS

5-Gal. Pail	11501
1-Qt. Bottle	11487



BREAK-IN OIL — TYPICAL PROPERTIES*

ASTM TESTS

D445	Viscosity	
	cSt @ 40°C	76
	cSt @ 100°C	12
	cSt @ 100°F	400
	cSt @ 210°F	65
D2270	Viscosity Index	155
D4684	Pumping Viscosity	
	cP @ -30°F	18,200
D93	Flash Point °F	400

* Properties are typical and may vary.



SNOW 2-C 2-CYCLE SNOWMOBILE MOTOR OIL



Royal Purple Snow 2-C is a high performance 2-cycle engine oil that improves performance and reduces wear in both standard and high performance 2-cycle snowmobile gasoline engines. The synthetic solvency of Snow 2-C keeps spark plugs and exhaust ports clean for maximum engine efficiency. This engine cleanliness, combined with Snow 2-C's low coefficient of friction promotes increased horsepower and engine speed.

Snow 2-C is formulated with Royal Purple's proprietary, synthetic Synerlec additive technology, that protects rings, bearings and cylinder walls from metal-to-metal contact and guards against scuffing, galling and welding, which can occur in severe conditions. Snow 2-C is ideally suited for snowmobile applications due to its low temperature fluidity and pumpability for cold weather service.

PERFORMANCE ADVANTAGES

- Greater wear protection
- Superior corrosion protection
- Saves fuel
- Reduces exhaust emissions
- Ashless
- Increases performance
- Keeps engines clean and burns clean

PART NUMBERS

55-Gal. Drum	55511
5-Gal. Pail	05511
1-Gal. Bottle	04511

SNOW 2-C — TYPICAL PROPERTIES*

ASTM TESTS		
D445	Viscosity	
	cSt @ 40°C	46
	cSt @ 100°C	8.4
	cSt @ 100°F	231
D5293	cSt @ 210°F	54
	Cranking Viscosity	
	cP @ -3°F	5,300
D2270	Viscosity Index	162
D92	Flash Point °F	270
	Pour Point °C	-51
	Total Base Number	10.0 min
D4502	Density	
	Specific Gravity @ 60 °F	0.863
	Pounds / Gallon	7.2

* Properties are typical and may vary.

Royal Purple HP 2-C is a high performance engine oil that improves performance and reduces wear in both standard and high performance 2-cycle gasoline engines.

Royal Purple HP 2-C is recommended for use in both pre-mixed and oil injected gasoline 2-cycle engines in outboard motors, motorcycles, jet skis, chain saws, etc. For cold weather oil injected applications, Royal Purple recommends its Snow 2-C.

The ashless formulation and synthetic solvency of HP 2-C keeps spark plugs and exhaust ports clean for maximum engine efficiency. This engine cleanliness combined with the low coefficient of friction of Royal Purple HP 2-C promotes increased horsepower and engine speed. Engines operate with greater combustion efficiency and go longer between overhauls when lubricated with HP 2-C.

PERFORMANCE ADVANTAGES

- Greater wear protection
- Increased horsepower
- Superior rust / corrosion protection
- Cooler operation and less parasitic power loss
- Ashless to minimize exhaust deposits



HP 2-C — TYPICAL PROPERTIES*

ASTM TESTS		
D445	Viscosity	
	cSt @ 40°C	46
	cSt @ 100°C	7.5
	cSt @ 100°F	240
	cSt @ 210°F	51
D2270	Viscosity Index	129
D92	Flash Point °F	240
	Pour Point °C	-45
	Total Base Number	10.0 min
D130	Corrosion Test	
	3 hrs. @ 210 °F	1a
	24 hrs. @ 210 °F	1a
D130	Rust Test	
	Fresh Water	Pass
	Salt Water	Pass

* Properties are typical and may vary.

PART NUMBERS

55-Gal. Drum	55311
5-Gal. Pail	05311
1-Gal. Bottle	04311
1-Qt. Bottle	01311



RACING OILS

At Royal Purple we recognize that no matter what type of racing you do, you require the best protection and performance for your vehicle. From grassroots micro-sprint, motocross, go-karts and junior dragster to road racing and rallycross, Royal Purple racing oils turn your racing ride into an outperformer from practice to the checkered flag.



XPR® EXTREME PERFORMANCE RACING OIL



MULTI-GRADE OILS

XPR 3.1 0W-5, XPR 0W-10, XPR 0W-20, XPR 0W-30, XPR 5W-20,
XPR 5W-30, XPR 10W-40, XPR 10W-60 & XPR 20W-50

Royal Purple XPR (Extreme Performance Racing) oils are recommended for use in various racing applications, and are popular in a variety of motorsports including: NASCAR, NHRA, World of Outlaws and Bonneville Salt Flats.

PERFORMANCE ADVANTAGES

- Greater wear protection on startup
- Increased horsepower
- Extends equipment life
- Compatible with conventional mineral and synthetic oils
- Non-foaming
- Outstanding rust / corrosion protection
- High temperature service capability
- XPR resists displacement, dilution and emulsion caused by exotic fuels, such as alcohol, methanol and nitrous oxide (N2O)

RACING OILS

XPR 0W-20 & 0W-30

New to the XPR racing oil product line, featuring the most advanced formulation technology.

- **XPR 3.1 0W-5** is the lowest viscosity racing motor oil designed for the most competitive classes such as Pro Stock, Pro Stock Bike, Comp Eliminator and NASCAR Cup (qualifying). The ultra low viscosity provides the most horsepower possible by keeping parasitic losses to an absolute minimum while providing unparalleled protection.
- **XPR 0W-10** is an ultra-light viscosity racing motor oil formulated for use in drag racing, motorcycle sprint racing, etc.
- **XPR 5W-20** is a light viscosity racing motor oil that is excellent for drag racing and kart racing.
- **XPR 5W-30** works well in a variety of applications from oval track late models to bracket racing. It is extremely versatile and produces excellent horsepower while preventing wear.
- **XPR 10W-40** is designed for marine, oval track and endurance car racing. Capable of withstanding long intervals of extreme heat, it is extremely popular in sprint cars, late models and World of Outlaws racing.
- **XPR 10W-60** is specifically formulated to increase horsepower and torque in high performance modified and racing engines and is popular in endurance road racing and rallycross.
- **XPR 20W-50** is formulated for running extended periods under extreme pressure and heat. It is used in oval track, marine and drag racing and is very popular in sprint cars, late models, truck pullers and bracket racing.

XPR® EXTREME PERFORMANCE RACING OIL

PART NUMBERS

XPR 3.1 0W-5	55-Gal. Drum	55205
	5-Gal. Pail	05205
XPR 0W-10	55-Gal. Drum	55009
	5-Gal. Pail	05009
	1-Qt. Bottle	01009
XPR 0W-20	55-Gal. Drum	55008
	5-Gal. Pail	05008
	1-Qt. Bottle	01008
XPR 0W-30	55-Gal. Drum	55010
	5-Gal. Pail	05010
	1-Qt. Bottle	01010
XPR 5W-20	55-Gal. Drum	55011
	5-Gal. Pail	05011
	1-Qt. Bottle	01011
XPR 5W-30	55-Gal. Drum	55021
	5-Gal. Pail	05021
	1-Qt. Bottle	01021
XPR 10W-40	55-Gal. Drum	55041
	5-Gal. Pail	05041
	1-Qt. Bottle	01041
XPR 10W-60	55-Gal. Drum	55061
	5-Gal. Pail	05061
	1-Qt. Bottle	01061
XPR 20W-50	55-Gal. Drum	55051
	5-Gal. Pail	05051
	1-Qt. Bottle	01051



XPR — TYPICAL PROPERTIES*

ASTM TESTS		GRADE								
		3.1	0W-10	0W-20	0W-30	5W-20	5W-30	10W-40	10W-60	20W-50
D4052	Density	0.8456	0.8614	0.8724	0.8758	0.8743	0.8795	0.8851	0.8859	0.8955
D445	Viscosity									
	cSt @ 40°C	12.07	25.8	39.8	44.8	46.41	53.8	72.7	136.9	149.52
	cSt @ 100°C	3.0	5.4	8.7	10.2	8.91	11.0	13.3	23.21	20.19
D2270	Viscosity Index	119	147	207	225	176	202	188	201	157
D2896	TBN, mg KOH/g	—	11.5	11.5	11.5	11.5	11.5	11.5	11.5	11.5
D664	TAN, mg KOH/g	—	—	—	—	—	—	—	—	—
D5293	Cold Crank Simulator									
	cP @ -35°C	—	2,287	4,326	4,366	—	—	—	—	—
	cP @ -30°C	—	—	—	—	3,594	3,965	—	—	—
	cP @ -25°C	—	—	—	—	—	—	3,946	5,713	—
	cP @ -20°C	—	—	—	—	—	—	—	—	—
	cP @ -15°C	—	—	—	—	—	—	—	—	—
D93	Flash Point °F	344	410	405	400	405	414	410	405	414
D130	Copper Corrosion	1a	1a	1a	1a	1a	1a	1a	1a	1a

* Properties are typical and may vary.



10
OF

NITRO PLUS RACING OIL



NITRO PLUS OILS
50, 60 & 70

PART NUMBERS

Nitro Plus 50	55-Gal. Drum	55950
	5-Gal. Pail	05950
Nitro Plus 60	55-Gal. Drum	55960
	5-Gal. Pail	05960
Nitro Plus 70	55-Gal. Drum	55970
	5-Gal. Pail	05970

Royal Purple Nitro Plus oils are straight-grade synthetic racing motor oils formulated specifically for use in blown alcohol, nitro-methane or any racing applications that experience excessive fuel dilution.

- **NITRO PLUS 50**
Viscosity typical of a SAE 50 oil.
- **NITRO PLUS 60**
Viscosity typical of a SAE 60 oil.
- **NITRO PLUS 70**
Viscosity typical of a SAE 70 oil.

EXCLUSIVE PERFORMANCE ADVANTAGES

- Greater wear protection
- Separates rapidly from alcohol/nitro methane
- Resists bearing washout
- Can withstand severe stress of high compression engines
- Non-Foaming
- Outstanding Rust/Corrosion Protection
- High Temperature Service Capability

NITRO PLUS — TYPICAL PROPERTIES*

	ASTM TESTS	GRADE		
		50	60	70
D445	Viscosity			
	cSt @ 40°C	128	180.2	274.9
	cSt @ 100°C	18.7	23.5	29.1
D2270	Viscosity Index	166	160	142
D2896	TBN, mg KOH/g	12.5	12	12.2

* Properties are typical and may vary.

Royal Purple's Racing ATF is a high performance lubricant designed for automatic transmissions using Ford Type F fluids. Racing ATF is formulated to deliver firm, positive shifts for greater clutch life and consistency. Its exceptional oxidation resistance allows for extended use and more time between fluid changes compared to conventional and other synthetic fluids. Please consult Royal Purple's automotive technical support department when choosing a transmission fluid.

Racing ATF is fortified with Royal Purple's proprietary Synerlec technology which is shown to make equipment run cooler, smoother and longer. Its high viscosity index provides exceptional performance at a wide temperature range making it ideal for both circle track and drag racing applications. Racing ATF is recommended for all high performance, non-electronic shift transmissions that use a Type F automatic transmission fluid.

Field testing in GM, Ford and Chrysler drag racing transmissions has shown Royal Purple Racing ATF to be very consistent in pass-to-pass performance and has resulted in the doubling or tripling of transmission component and fluid life.



PART NUMBER

5-Gal. Pail ... 10154

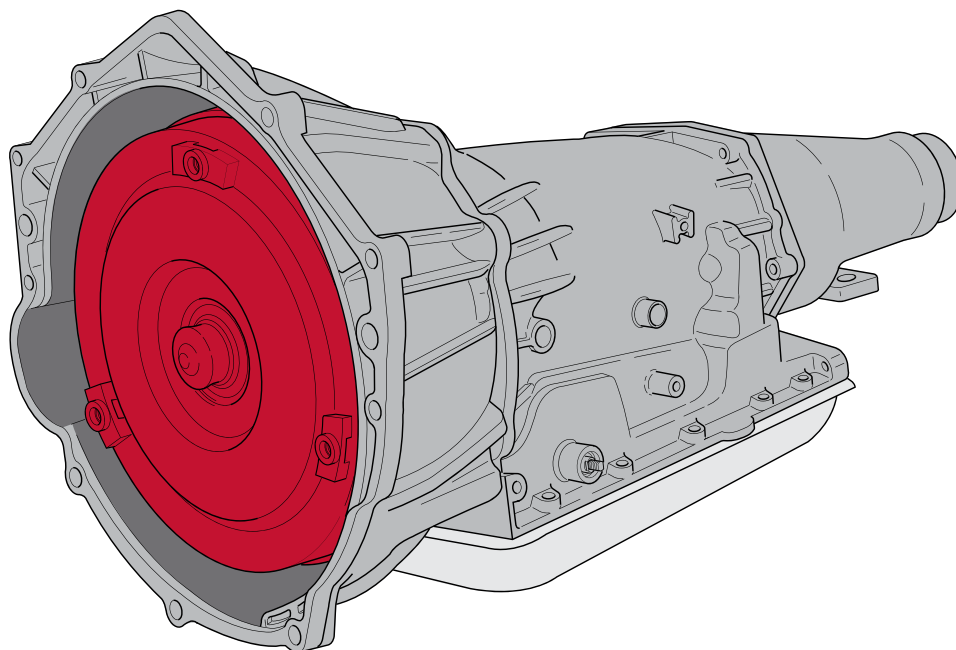



TRANSMISSION FLUIDS

Manual or automatic transmissions, Royal Purple has you covered. Compatible with other friction materials and transmission fluids, you'll notice the difference the first time you shift.



IMAGE - Ringbrothers / Not Stock Photography

MAX ATF® AUTOMATIC TRANSMISSION FLUID



Royal Purple Max ATF is a synthetic, high performance, automatic transmission fluid. Its high film strength helps to dramatically reduce heat and wear.

Automatic transmissions generate a great deal of heat and depend on the transmission fluid for cooling and protection. More than 90 percent of all automatic transmission failures are caused by overheating. A 20°F reduction in fluid temperature can double the life of the transmission (Source: Perma Industries Inc.). Max ATF significantly reduces heat to extend the life of your transmission.

Max ATF is fully compatible and can be mixed with other automatic transmission fluids; however, for the best results drain or flush the current oil and then fill with Max ATF. Max ATF is recommended in vehicles requiring any of these automatic transmission fluids:

- Allison C-4, TES-295
- Audi G-052-162, G-052-990, G-055-025
- BMW 7045E, LA2634, LT71141
- Chrysler ATF+, ATF+2, ATF+3, ATF+4
- Chrysler Mopar AS68RC
- Ford FNR5, MERCON®, MERCON® V
- GM DEXRON®, DEXRON® II, DEXRON® IID, DEXRON® IIE, DEXRON®-IIIF, DEXRON® IIIG, DEXRON®-IIIH
- Esso LT 71141
- Honda ATF-Z1 (except in CVT's)
- Hyundai SP-II, SP-III
- JWS 3309, JWS 3314, JWS 3317
- Kia Red-1, SP-II, SP-III
- Idemitsu K17
- JASO 1-A
- MAN 339F, 339 V1, 339 V2, 339 Z1, 339 Z2
- Mazda ATF-M III, ATF-MV
- Mercedes Benz 236.1, 236.2, 236.3, 236.5, 236.6, 236.7, 236.9, 236.10, 236.11
- Mitsubishi SP-II, SP-III
- Nissan 402, Matic-D, Matic-J, Matic-K
- Shell 3403, LA2634, M-1375.4 (ZF 6-Speed AT)
- Subaru ATF, ATF-HP
- Suzuki 3314, 3317
- Texaco ETL-7045E, ETL-8072B, N402
- Toyota T-III, T-IV
- Voith 55.6335.XX (G607)
- Volvo Pass Car (4-6 Speed AT), 97340 (Construction Equipment), 97341
- VW G-052-162, G-052-990, G-055-025
- ZF TE-ML, 03D, 04D, 05L, 09, 11B, 14A, 16L, 17C, TE-ML 14B

PLEASE NOTE: Max ATF is NOT recommended for the following applications: Allison TES-389, DEXRON® VI, Ford Type F and MERCON® SP & LV, Honda DW-1, Hyundai SP-IV and NWS-9638, Kia SP-IV, JWS 3324, MAN 339 Z3, Mercedes Benz 236.8, 236.12, 236.14 & 236.15, Mitsubishi SP-IV and ATF J2, Nissan Matic-S, Saab 93-165-147, Toyota WS (JWS 3324) and ZF TE-ML 14C. Max ATF is not recommended for use in any CVT or DCT applications.

Dexron® is a registered trademark of General Motors Corporation.
Mercon® is a registered trademark of Ford Motor Company.

PART NUMBERS

55-Gal. Drum	55320
5-Gal. Pail	05320
1-Qt. Bottle	01320

MAX ATF — TYPICAL PROPERTIES*

ASTM TESTS

ASTM TESTS	Value
D445 Viscosity	
cSt @ 40°C	38
cSt @ 100°C	7.5
SUS @ 100°F	192
SUS @ 210°F	50
cP @ -10°C (14°F)	550
D2983 Brookfield Viscosity	
cP @ -20°C (-4°F)	1,100
cP @ -30°C (-22°F)	2,520
cP @ -40°C (-40°F)	7,950
D2270 Viscosity Index	169
D92 Flash Point °F	395
D97 Pour Point °C	-69
D4052 Density	
Specific Gravity @ 60°F	0.84
Pounds / Gallon	7.01

* Properties are typical and may vary.

SYNCHROMAX® MANUAL TRANSMISSION FLUID

Royal Purple Synchronmax is recommended for manual transmissions that specify an automatic transmission fluid or other light-viscosity oil. It is also ideal for transfer cases and 2-cycle motorcycle gear boxes that specify light-viscosity lubricants.

Synchronmax is formulated with Royal Purple's synthetic, proprietary Synerlec additive technology, offering improved shift quality over a wide temperature range and reduced gear noise.

Synchronmax is fully compatible with all types of friction materials and offers excellent corrosion and oxidation protection without affecting the soft metals commonly found in manual transmission synchronizers.

PERFORMANCE ADVANTAGES

- Greater wear protection
- Smoother shifts
- Excellent rust / corrosion protection
- Reduces friction for more power
- Lowers operating temperatures
- Can be used as a replacement for Auto-Trak II, VersaTrak® and Synchronmesh



SYNCHROMAX — TYPICAL PROPERTIES*

ASTM TESTS		
D445	Viscosity	
	cSt @ 40°C	39
	cSt @ 100°C	7.5
	SUS @ 100°F	200
	SUS @ 210°F	51
	cP @ -10°C (14°F)	550
D2983	Brookfield Viscosity	
	cP @ -20°C (-4°F)	1,330
	cP @ -30°C (-22°F)	3,100
	cP @ -40°C (-40°F)	9,178
D2270	Viscosity Index	162
D92	Flash Point °F	405
D97	Pour Point °C	-51
D4052	Density	
	Specific Gravity @ 60°F	0.847
	Pounds / Gallon	7.06

* Properties are typical and may vary.

PART NUMBERS

55-Gal. Drum	55512
5-Gal. Pail	05512
1-Qt. Bottle	01512





GEAR OILS

Royal Purple's gear oil has the ability to protect and outperform ordinary oils by combining our proprietary additive technology and friction modifiers. Available in viscosities for automotive and marine applications, our high performance gear oils will provide high performance results that will keep your gears running smoother and longer.

MAX GEAR® GEAR OIL



Royal Purple Max Gear is recommended for use in automotive front and rear differentials, manual transmissions and transfer cases that specify use of an API GL-5 or GL-4 fluid. It is noncorrosive to soft yellow metals (brass, bronze, copper), and is synchronizer safe.

Max Gear is an ultra-tough, high performance gear oil designed to provide maximum protection to heavily loaded gears while maximizing power throughout the drivetrain. Max Gear outperforms ordinary gear oils by combining the highest quality synthetic oils with Royal Purple's proprietary Synerlec additive technology. Max Gear makes gears run smoother, quieter, cooler and longer without overhauls.

PERFORMANCE ADVANTAGES

- Maximizes horsepower
- Extends gear and bearing life
- Reduces operating temperature
- Severe service performance
- Lower coefficient of friction
- Superior corrosion protection
- Separates rapidly from water
- Environmentally responsible
- For use with open, limited-slip and locking differential
- Contains limited-slip friction modifier

MAX GEAR — TYPICAL PROPERTIES*

ASTM TESTS		SAE GRADE				
		75W-90	75W-140	80W-90	85W-140	90
D445	Viscosity					
	cSt @ 40°C	100	187	160	313	176
	cSt @ 100°C	16.5	27.5	17.4	28.5	17.5
D2983	Brookfield Viscosity					
	cP @ -12°C	—	—	—	22,000	—
	cP @ -26°C	—	—	57,000	—	—
	cP @ -40°C	65,000	135,000	—	—	—
D92	Flash Point °F	325	375	350	350	330
	Pour Point °C	-51	-54	-39	-39	-36

* Properties are typical and may vary.

PART NUMBERS

75W-90	55-Gal. Drum	55300	80W-90	55-Gal. Drum	55302	
	15-Gal. Keg	16300		5-Gal. Pail	05302	
	5-Gal. Pail	05300		85W-140	55-Gal. Drum	55303
	1-Qt. Bottle	01300			15-Gal. Keg	16303
75W-140	55-Gal. Drum	55301	5-Gal. Pail		05303	
	15-Gal. Keg	16301	1-Qt. Bottle	01303		
	5-Gal. Pail	05301	SAE 90	55-Gal. Drum	55304	
	1-Qt. Bottle	01301		5-Gal. Pail	05304	

Royal Purple HPM Gear Lube is formulated to maximize performance and provide Synthetic Defense™ for marine lower gear units and outdrives. Its cushioning molecules absorb gear impact to dramatically minimize wear. HPM Gear Lube also significantly reduces friction, which lowers gear unit temperatures, extends equipment life and improves fuel efficiency.

HPM Gear Lube uses Royal Purple's advanced, proprietary Synerlec additive technology for maximum water separation and protection from corrosion. It is recommended for equipment requiring an API Service GL-5 or GL-4 fluid.

PERFORMANCE ADVANTAGES

- Reduces wear and heat to extend the life of your lower unit
- Provides maximum water separation and prevents corrosion
- Improves fuel efficiency

ASTM D-1401 DEMULSIBILITY TEST

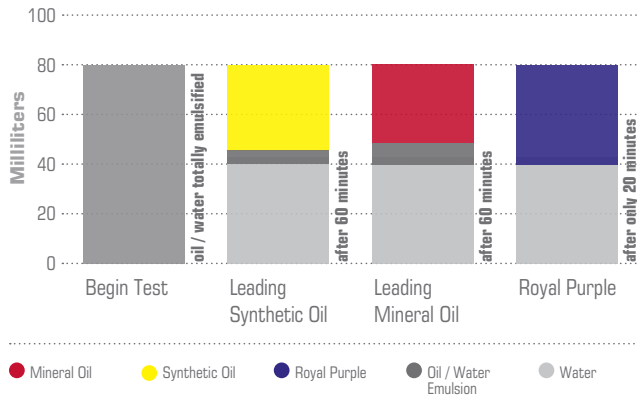

HPM GEAR — TYPICAL PROPERTIES*

ASTM TESTS		SAE GRADE
		80W-90
D445	Viscosity	
	cSt @ 40°C	165.7
	cSt @ 100°C	17.9
D2983	Brookfield Viscosity	
	cP @ -26°C	59,000
D2270	Viscosity Index	119
D92	Flash Point °F	370

* Properties are typical and may vary.



PART NUMBERS

80W-90	5-Gal. Pail	11689
	1-Qt. Bottle	11687





RINGBROTHERS USE ROYAL PURPLE EXCLUSIVELY

PERFORMANCE ADDITIVES

Royal Purple's premium synthetic products go beyond lubrication. Our line of performance additives are formulated to improve fuel economy and restore power for gasoline and diesel vehicles, boats, lawn and seasonal equipment.



MAX-CLEAN® FUEL SYSTEM CLEANER



PART NUMBERS

20-Oz. Bottle	11722
6-Oz. Bottle	11754

Royal Purple Max-Clean is a state-of-the-art high performance synthetic fuel system cleaner that maximizes the performance of your fuel system. Max-Clean restores fuel economy and deeply penetrates and cleans injectors, carburetors, intake valves and combustion chambers.

The illustration below shows the before and after effects of switching to Max Clean.

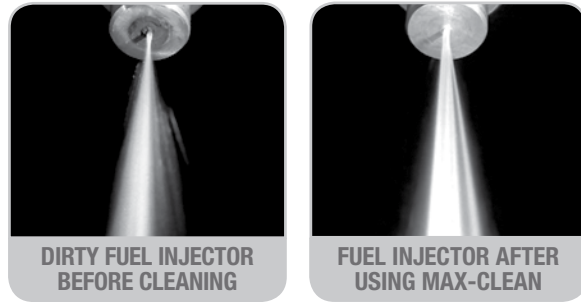

Illustration of before and after effects.

Royal Purple Max-Clean is EPA / CARB Compliant. Safe for use in gasoline and diesel engines and can be used with all ethanol blends or biofuel. Max-Clean can be used in both 4-cycle & 2-cycle engines and will not harm vehicle emissions equipment.

PERFORMANCE ADVANTAGES

Multiple product fleet tests were conducted on various makes and models of vehicles. Royal Purple found that after as little as one treatment Max-Clean can:

- Improve fuel economy an average of 3.2 - percent
- Restore horsepower an average of 2.6 - percent
- Reduce hydrocarbon, NOx and CO emissions (on average 12, 13 and 18 - percent respectively)
- Prevent rough idle, hesitation and stalling
- Prevent premature spark plug fouling
- Reduce deposit-related engine knocking and pinging
- Stabilizes fuel during off-season and storage
- Superior corrosion and oxidation inhibitor

RECOMMENDED TREAT RATE

Pour entire contents of 20oz. can into a nearly empty tank and refuel. One (1) can treats up to 20 gallons. For tank sizes outside of this range, use one (1) ounce per gallon. In two-cycle engines, use one (1) ounce per gallon.

RECOMMENDED USAGE

20oz. - Recommended usage is every 10,000 miles.
6oz. - Recommended usage is every 3,000 miles.

MAX-ATOMIZER™ FUEL INJECTOR CLEANER

Royal Purple's Max-Atomizer is a fully-synthetic, highly concentrated, high performance fuel injector cleaner. It is specially formulated to solve problems with today's direct injection engines, but can be used with any type of fuel injection. Max-Atomizer contains highly concentrated polyether amine (PEA) detergents that quickly clean clogged and coked injectors, restores maximum injector flow. This optimizes injector spray patterns and better atomizes fuel as it enters the combustion chamber. The result is improved fuel economy, enhanced power and performance, reduced emissions, smoother idle, and quicker / easier starts. Max-Atomizer is the only fuel injector cleaner that also stabilizes ethanol, which chemically breaks down to cause harmful effects to an engine.

PERFORMANCE ADVANTAGES

- Restores fuel economy
- Stabilizes Ethanol
- Maximizes horsepower
- Improves responsiveness
- For use in both gasoline and diesel engines
- Recommended for all ethanol blends
- Will not harm vehicle emissions equipment
- EPA / CARB Compliant

RECOMMENDED TREAT RATE

Pour entire contents of bottle into nearly empty fuel tank. Minimum recommended dose is one (1) 6oz. bottle to 20 gallons of fuel. The maximum effective dose is one (1) 6oz. bottle to 10 gallons of fuel.

RECOMMENDED USAGE

For best results, use at every fill-up.



PART NUMBERS

6-Oz. Bottle : 18000

MAX ATOMIZER RESTORES FUEL INJECTOR FLOW

MILEAGE	INJECTOR 1	INJECTOR 2	INJECTOR 3	INJECTOR 4
0	100	100	100	100
200	97.5	98	96.5	96.5
400	94	96	93	92
600	92	95	90	87
800	88	93.5	87	85
1,000	86	92	83	80.5
1,200	83	90	80	77.5
1,400	80	87	77	73
1,504	79	86.5	75.5	72
1,600	85	90.5	80	79
1,800	99	99	93	92.5

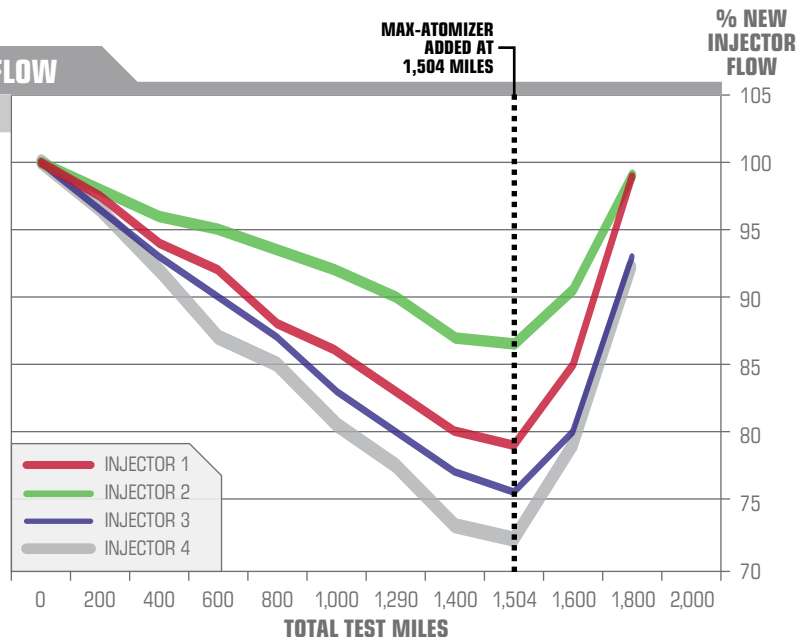

MAX-TANE® TOTAL DIESEL PERFORMANCE



ALSO AVAILABLE IN 10 OZ. - Treats up to 50 gallons.

PART NUMBERS

20-Oz. Bottle	11755
10-Oz. Bottle	11756

Royal Purple's Max-Tane is formulated for year-round use in all types of light, medium and heavy duty diesel engines, and is compatible with any type or grade of diesel fuel, including #1 diesel and #2 diesel, biodiesel and ultra-low-sulfur diesel (ULSD). Max-Tane is specifically formulated to solve problems associated with today's new HPCR (High Pressure Common Rail) diesel injection systems. Safe for use with all types of diesel exhaust emission systems equipment, including diesel particulate filters (DPFs) and catalytic converters. Do not pour into Diesel Exhaust Fluid.

PERFORMANCE ADVANTAGES

- Increases Cetane Number by 8*
- Increases fuel economy by up to 10%
- Improves engine startup and reliability in both warm and cold temps
- Improves cold flow by preventing gelling
- Cleans deposits from fuel injectors, combustion chambers, intake valves and piston crowns
- Provides lubricity to entire fuel system
- Reduces smoke and odor

* When used as directed.

RECOMMENDED TREAT RATE

The minimum recommended dosage is one (1) ounce per five (5) gallons of diesel fuel. High performance applications can safely use one (1) ounce per two (2) gallons of diesel fuel for maximum benefit. If uncertain of exact tank size, round up. Replace cap after bottle has been emptied and dispose of properly.

20 Ounces	→	100 Gallons
15 Ounces	→	75 Gallons
10 Ounces	→	50 Gallons
5 Ounces	→	25 Gallons

Royal Purple's Max-Boost is a high-performance octane booster with fuel treatment that increases gasoline octane, reduces emissions, and enhances engine performance while stabilizing fuel. Max-Boost is formulated with MMT, which delivers the best octane enhancement to help eliminate engine damaging detonation, pre-ignition, and pinging or knocking from low octane gasoline.

Max-Boost is formulated for engines equipped with carburetors, port fuel injection and direct injection, as well as turbocharged, supercharged and nitrous-injected engines. Safe for use in leaded and unleaded gasolines, and alternate fuels like gasohol, reformulated gasoline, and all ethanol blends. Max-Boost is safe for oxygen sensors and catalytic converters.

PERFORMANCE ADVANTAGES

- Reduces engine knocking and pinging
- Raises octane rating up to 30 points or 3 numbers
- Restores power and fuel economy
- Cleans deposits from fuel injectors
- Reduces power loss due to knock-retard in computer controlled vehicles
- Replaces lead additives for protection of non-hardened valve seats
- Stabilizes fuel

RECOMMENDED TREAT RATE

One can treats up to 25 gallons of gasoline. Pour entire can into tank before fill-up. Clean immediately if spills occur, as product can permanently stain painted surfaces. Do not expose liquid to direct or indirect sunlight. Replace cap after can has been emptied, and dispose of properly.

PLEASE NOTE: Max-Boost is a racing formula and is not street legal.

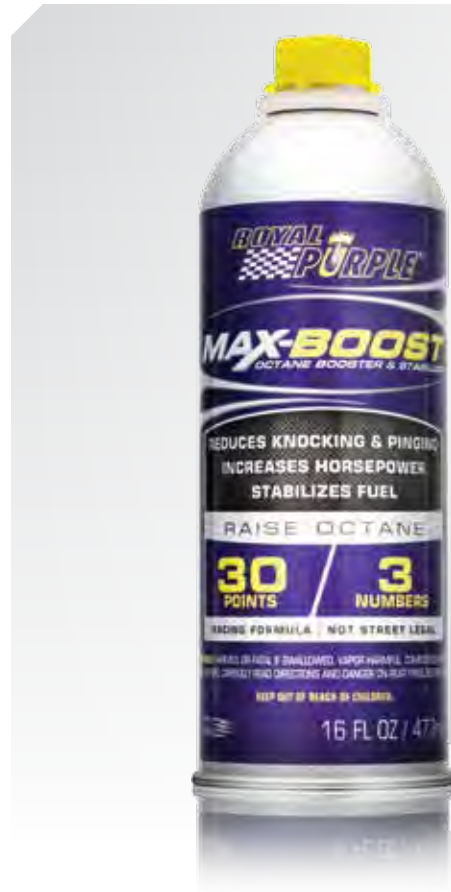

PART NUMBERS

16-Oz. Bottle :: 11757

ROYAL FLUSH™ COOLING SYSTEM FLUSH



Royal Flush from Royal Purple is an engine cooling system flush and cleaner that maintains and restores cooling system efficiency. Using a proprietary formula originally developed for cleaning high-end, industrial cooling towers and heat exchangers, Royal Flush contains unique technology not found in any other automotive cooling system flush and/or cleaner on the market. A highly concentrated product, Royal Flush helps remove oils, scums, gels, slimes, corrosion byproducts, and other contaminants. It is a one-step product that contains no acids, is completely safe to use, and does not require use of a post-flush neutralizer. It cleans the entire cooling system, neutralizes acidic build-up, and restores cooling efficiency.

Royal Flush maintains clean metal surfaces inside engines and radiators, which optimizes heat transfer. Over time, inhibitors in antifreeze, contaminants in water, and tiny rust particles become insoluble, and form antifreeze gels. Royal Flush contains industrial-grade detergents that chemically “scrub” surfaces inside the cooling system to remove contaminants. Using corrosion inhibitors that “prime” metal surfaces inside the cooling system, Royal Flush prepares the cooling system for follow-up treatment with Purple Ice.

PERFORMANCE ADVANTAGES

- Optimizes cooling efficiency and prevents overheating
- Cleans radiator and entire cooling system
- Neutralizes combustion by-products
- pH balanced to protect aluminum radiators

RECOMMENDED TREAT RATE

One (1) 12 ounce bottle will treat cooling systems with a coolant capacity of up to 16 quarts. For cooling systems with a coolant capacity of more than 16 quarts, it is recommended to use two (2) bottles of Royal Flush.

PART NUMBERS

12-Oz. Bottle 01650

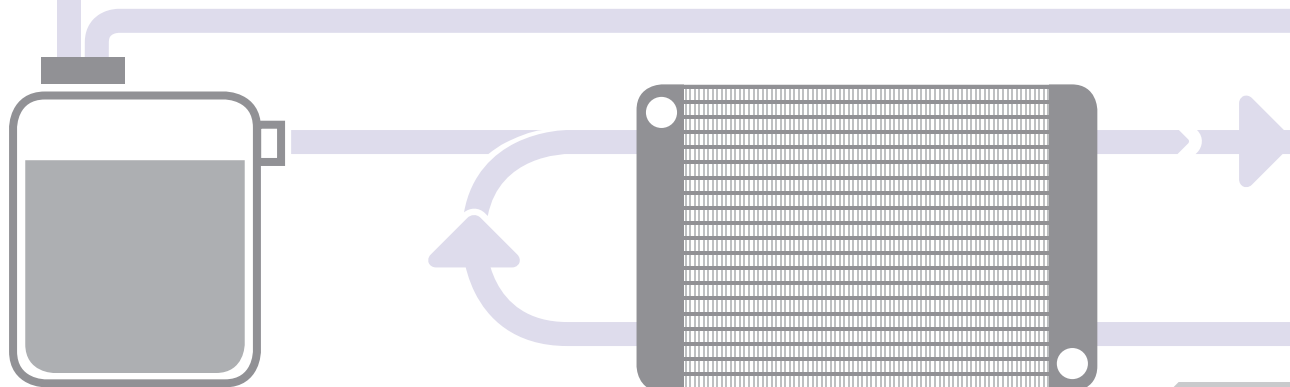

Royal Purple's Purple Ice® is a high performance radiator conditioner. Its advanced 2-in-1 corrosion inhibitor and wetting agent provides year-round defense against corrosion and reduces the surface tension of the radiator coolant to help reduce engine temperatures.

REDUCED COOLANT TEMPERATURES

Extensive testing confirms Purple Ice reduces coolant temperatures better than comparable products while providing extra corrosion protection. For example, the average operating temperature of a 350 c.i.d. V8 engine (equipped with 160° thermostat) when dyno-tested with different coolants are:

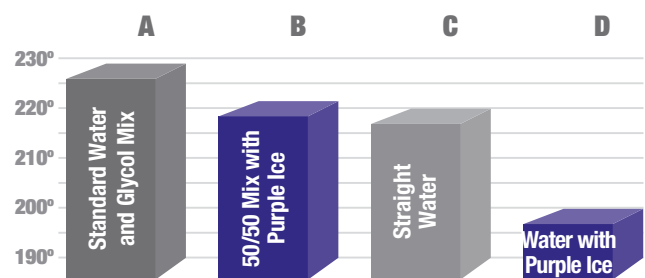

- A. Standard mix of water and glycol (antifreeze) — 228°F
- B. 50/50 water/glycol mix with Purple Ice added — 222°F
- C. Straight water (no corrosion protection) — 220°F
- D. Water with Purple Ice added — 200°F

PERFORMANCE ADVANTAGES

- Reduces surface tension of a coolant allowing more heat to transfer outside the radiator resulting in more horsepower
- Reduces hot spots in the engine and cylinder heads, reducing the possibility of engine failure
- Helps prevent overheating, keeps the system clean and extends the life of the water pump
- Purple Ice is safe to use with water-only or antifreeze / water blends
- Purple Ice is compatible with OEM and stock replacement coolants, including extended-life antifreezes
- Purple Ice does not contain glycol and is safe and legal for track use



PART NUMBERS

12-Oz. Bottle : 01600

RECOMMENDED TREAT RATE*

- For use with antifreeze:
1 oz. / quart of cooling system capacity
- For straight water applications:
2 oz. / quart of cooling system capacity

* Minimum of 20% antifreeze is recommended in street-driven vehicles.

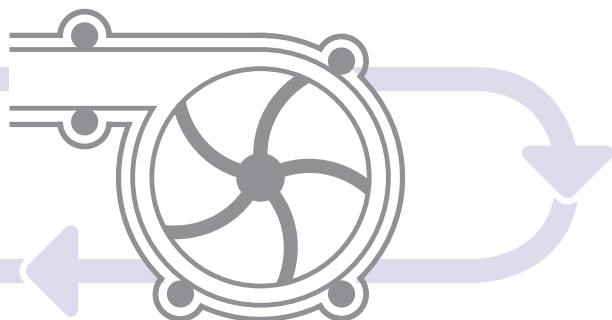

See how Purple Ice outperforms the leading competitor on page 42.

Purple Ice® is more than just a coolant additive.

It's a high performance radiator conditioner with an advanced 2-in-1 corrosion inhibitor and wetting agent to provide year-round protection while reducing engine temperature and improving performance.



PASS

PASS

4x More Protection
than Competitive Product

PASS

VS

LEADING COMPETITOR

ASTM D1384:
MULTI-METAL CORROSION TEST

FAIL

ASTM D4340:
ALUMINUM CORROSION TEST

PASS

4x Less Protection
than Purple Ice

ASTM D1881:
COOLANT FOAMING TEST

FAIL

Three ASTM industry standard engine coolant performance tests performed by a leading OEM-approved, third party coolant test laboratory.



- Superior protection of aluminum components in cooling systems of today's new cars and trucks.
- Superior protection against foam, which causes premature water pump failure.
- Superior anti-foam ingredients, which will not polymerize to form slimes*

*The leading competitor contains anti-foam ingredients that can polymerize to form brown slimes, which coat a cooling system and reduce heat transfer

Independent tests confirm

PURPLE ICE OUTPERFORMS THE COMPETITION!

REDUCES ENGINE TEMPERATURES

Extensive testing confirms Purple Ice reduces engine temperatures better than comparable products while providing advanced corrosion protection.

AVERAGE OPERATING TEMPERATURES: 350 C.I.D. V8 ENGINE
(EQUIPPED WITH 160° THERMOSTAT)

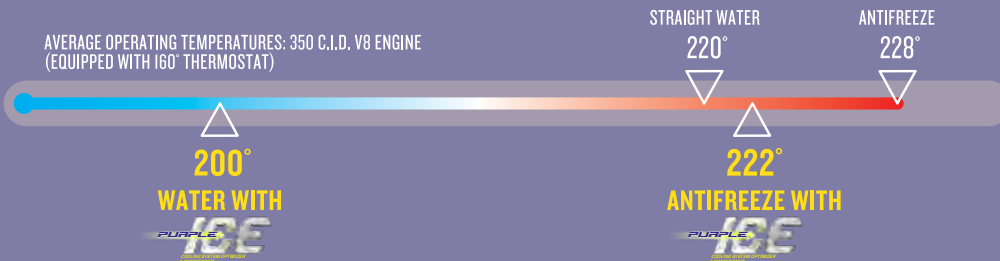

RECOMMENDED TREAT RATE*

FOR USE WITH ANTIFREEZE:
1 oz. / quart of cooling system capacity
FOR STRAIGHT WATER APPLICATIONS:
2 oz. / quart of cooling system capacity

*minimum of 20% antifreeze is recommended in street-driven vehicles



IMPROVED PERFORMANCE

Reduces coolant surface tension, which enhances heat transfer and allows an engine to make more power



REDUCED HEAT

Reduces hot spots in the engine and cylinder heads, reducing the possibility of engine damage due to detonation



MAXIMUM PROTECTION

Helps prevent overheating, keeps the system clean and corrosion-free, and extends the water pump life



COMPATIBLE

Safe to use with any type of antifreeze, or even with straight water

SWITCH TO PURPLE ICE TODAY, AND USE OUR NEW ROYAL FLUSH™ TO HELP REMOVE SLIME COATINGS LEFT BEHIND BY THE LEADING COMPETITOR!





SPECIALTY LUBRICANTS

Royal Purple offers a variety of synthetic Synerlec infused lubricants for a wide range of uses in both the DIY garage and home. Convenient and easy to use, these lubricants include assembly lube, grease, chain lube, multi-purpose spray lubricant and an aerosol gun oil.



MAX EZ® POWER STEERING FLUID



Royal Purple Max EZ is an advanced power steering fluid designed to maximize the life and performance of all power steering units. Max EZ is formulated with a blend of select synthetic base oils plus Royal Purple's proprietary Synerlec additive technology, which is proven to make equipment run cooler, longer, quieter and more efficiently. Max EZ is compatible and can be mixed with **any** OEM or stock replacement power steering fluid and has excellent seal compatibility.

PERFORMANCE ADVANTAGES

- Greater wear protection
- Clean, efficient equipment
- Extended pump life
- Much longer fluid life
- Non-foaming
- Outstanding rust / corrosion protection
- High temperature service capability

PART NUMBERS

12-Oz. Bottle : 01326

MAX-EZ — TYPICAL PROPERTIES*

ASTM TESTS		
D445	Viscosity	
	cSt @ 40°C	48
	cSt @ 100°C	8.5
	SUS @ 100°F	243
D2270	Viscosity Index	54
		153
D92	Flash Point °F	400
	Flash Point °C	-45
D4052	Density	
	Specific Gravity @ 60°F	0.87
	Pounds / Gallon	7.28

* Properties are typical and may vary.

MAX-TUFF® SYNTHETIC ASSEMBLY LUBRICANT

Royal Purple Max-Tuff is an ultra-tough, synthetic lubricant. It's designed for use in the build or repair of any mechanical component that needs immediate lubrication and protection from the first use. Max-Tuff utilizes unique, synthetic molecules that adhere to metal surfaces to create a formidable, load-bearing physical barrier between surfaces. This minimizes the metal-to-metal contact and wear in boundary lubrication conditions. It also provides excellent protection against rust and corrosion of both ferrous and nonferrous metals.

PERFORMANCE ADVANTAGES

- Greater wear protection
- Clean, efficient equipment
- Extends equipment life
- Compatible with conventional mineral and synthetic oils
- Non-foaming
- Outstanding rust / corrosion protection
- High temperature service capability



MAX-TUFF — TYPICAL PROPERTIES*

ASTM TESTS		
D445	Viscosity	
	cSt @ 40°C	650
	cSt @ 100°C	47
	SUS @ 100°F	3,450
D2270	Viscosity Index	122
	Flash Point °F	375
D92	Flash Point °C	-39
	Density	
D4052	Specific Gravity @ 60°F	0.879
	Pounds / Gallon	7.33

* Properties are typical and may vary.

PART NUMBERS

8-Oz. Bottle	01335
2-Oz. Bottle	10553

MAX-CHAIN® SYNTHETIC CHAIN LUBRICANT



Royal Purple Max-Chain is an advanced, high performance, synthetic lubricant that provides excellent protection for chains, open gears and exposed metal surfaces subjected to severe loading — even in dusty, wet, acidic environments.

Max-Chain is a unique, thixotropic lubricant blended with a solvent carrier. When applied, Max-Chain penetrates the rollers, pins and bushings of the chain, then the carrier evaporates leaving a tenacious, dry, wax-like film. This non-tacky film effectively minimizes the collection of abrasive dust and other airborne contaminants. The EP properties of Max-Chain greatly reduce wear and effectively extend equipment life. Max-Chain can lubricate up to 400°F (after carrying solvent has evaporated) and provides excellent protection against rust and corrosion. Max-Chain uses a non-petroleum CO₂ propellant.

PERFORMANCE ADVANTAGES

- Easily applied
- Long lasting
- Does not attract dust / particulates
- Protects heavily loaded surfaces
- Excellent corrosion protection
- Environmentally responsible

PART NUMBERS

4-Oz. Can : 11407

MAX-CHAIN — TYPICAL PROPERTIES*

ASTM TESTS		
D445	Viscosity	
	cSt @ 40°C	4.9
	cSt @ 100°C	1.7
	SUS @ 100°F	43
	SUS @ 210°F	32
	Aerosol Flash °F	200 min.

* Properties are typical and may vary.

MAXFILM® SYNTHETIC PENETRATING LUBRICANT

Royal Purple Maxfilm is a high film strength, multipurpose, synthetic lubricant / penetrant that excels in a wide array of applications. Maxfilm deeply penetrates, cleans and loosens rusted parts. Once applied, its solvent carrier evaporates and leaves a tenacious, thixotropic lubricating film on all metal surfaces, providing long-lasting protection against wear, rust and corrosion.

Maxfilm contains Royal Purple's proprietary Synerlec® additive technology, which is proven to make equipment run smoother, cooler, quieter, longer and more efficiently. Maxfilm uses a non-petroleum (CO₂) propellant.

PERFORMANCE ADVANTAGES

- Greater wear protection
- Clean, efficient equipment
- Extended pump life
- Much longer fluid life
- Non-foaming
- Outstanding rust / corrosion protection
- High temperature service capability

MAXFILM IS RECOMMENDED FOR:

- Loosening stuck parts such as nuts, bolts, locks, hinges, etc.
- Lubrication of power tools, hinges, chains, rollers, open gears, fishing tackle, lawn equipment, etc.
- Preserving and protecting parts in storage, disassembled machinery parts, wire ropes, etc., against rust and corrosion
- Use as a manual cutting fluid to facilitate the ease of hand drilling, tapping, metal cutting, etc., of steel and aluminum



PART NUMBERS

11-Oz. Can	05000
4-Oz. Can	10035

MAXFILM — TYPICAL PROPERTIES*

ASTM TESTS		
D445	Viscosity	
	cSt @ 40°C	7.1
	cSt @ 100°C	2.1
	SUS @ 100°F	50
	SUS @ 210°F	33
D2270	Viscosity Index	101
	Aerosol Flash °F	215 min.

* Properties are typical and may vary.



SYNTHETIC GUN OIL



Royal Purple Synthetic Gun Oil is recommended for cleaning of all firearms after use and for preserving them while in storage.

Royal Purple Synthetic Gun Oil is an advanced, high performance lubricant that is specifically formulated to provide exceptional wear protection as well as protection against saltwater and rust corrosion. It also prevents fouling.

Royal Purple Synthetic Gun Oil works well in a variety of temperatures and will not thicken in cold weather. Its performance advantages stem from Synerlec®, Royal Purple's proprietary additive technology.

In addition to gun applications, Royal Purple Synthetic Gun Oil can also be used for fishing tackle, locks and hinges.

PERFORMANCE ADVANTAGES

- Easily applied
- Long lasting
- Excellent for preserving and protecting parts in storage
- Excellent corrosion protection
- Environmentally responsible

PART NUMBERS

4-Oz. Can 10036

GUN OIL — TYPICAL PROPERTIES*

ASTM TESTS

D445	Viscosity	
	cSt @ 40°C	29.3
	cSt @ 100°C	5.5
D2270	Viscosity Index	124
D664	TAN, mg KOH/g	11.6
D93	Flash Point °F	400

* Properties are typical and may vary.

“I’ve tried every gun lube out there and none of them compare to Royal Purple.”

—Bobby Fowler, Jr.
World Champion Sporting Clay Shooter
and Elite Shooting School Instructor



SYNFILM RECIP. 100 RECIPROCATING AIR COMPRESSOR OIL

Royal Purple Synfilm Recip. 100 is recommended for lubrication of reciprocating air compressors (piston type) that specify a SAE 30 or a “non-detergent” 30 weight oil.

Synfilm Recip. 100 is a long life, high film strength, energy efficient, synthetic lubricant that significantly increases the reliability and efficiency of reciprocating air compressors and reciprocating shop compressors. It excels at reducing wear and keeping discharge valves free of harmful carbon deposits. Synfilm Recip. 100 forms a better seal and reduces friction between the cylinder wall and piston rings for greater compressor efficiency. It is formulated with Royal Purple’s unique, proprietary Synerlec additive technology, which is proven to make equipment run smoother, cooler, quieter, longer and more efficiently.

SYNFILM RECIP 100 — TYPICAL PROPERTIES*

ASTM TESTS		ISO GRADE
D445	Viscosity	
	cSt @ 40°C	100
	cSt @ 100°C	10.1
	SUS @ 100°F	560
	SUS @ 210°F	
D92	Flash Point °F	460
	Pour Point °C	-39
D4052	Density	
	Specific Gravity @ 60 °F	0.957
	Pounds / Gallon	7.98
D664	Acid Number	0.23
D1401	Demulsibility	40/40/0/30
D892	Foam Tests	
	Sequence I, II & III	Pass
D130	Copper Corrosion	
	3 hrs. @ 210°F	1a
	250 hrs. @ 210°F	1a
	Cincinnati Millicron “A”	
	Corrosion / Oxidation	Pass
D665	Rust Test	
	Fresh Water	Pass
	Salt Water	Pass
D2893	Dry Air Oxidation	
	312 hrs. @ 203°F	
	% Viscosity Increase	0
	Precip. No. (% Solids)	0

* Properties are typical and may vary.



PART NUMBERS

1-Gal. Bottle	04513
1-Qt. Bottle	01513

PERFORMANCE ADVANTAGES

- High film strength
- Rapidly separates from water
- Saves energy
- Synthetic solvency
- Longer oil life
- Excellent corrosion protection
- Compatible with other oils



UPG® ULTRA-PERFORMANCE GREASE



PART NUMBERS

35lb. / 5-Gal. Pail	35312
14.1-Oz. Tube	01312

Royal Purple Ultra-Performance Grease (UPG) is a high performance, multi-service, aluminum-complex, synthetic EP grease which significantly increases bearing life and equipment reliability. It also makes bearings run smoother, cooler and quieter.

UPG satisfies a wide range of grease requirements from the lubrication of bearings to u-joints and general-purpose use. It has outstanding extreme pressure capabilities and excellent water resistance to both emulsion and washout. UPG is stable at high temperatures. It also has excellent oxidation resistance for extended service life and to provide a margin of safety between lubrication intervals.

PERFORMANCE ADVANTAGES

- Handles extreme loads
- Reduces heat
- Reduces wear
- Lowers operating temperatures
- Reduces vibrations

UPG — TYPICAL PROPERTIES*

ASTM TESTS

D445	Viscosity (base oil) cSt @ 40°C	150
	NLGI Grade	Grade 2
	Texture	Buttery
	Drop Point °F	520
	Thickener Type (soap base)	Aluminum Complex
D4052	Density	
	Specific Gravity @ 60 °F	0.90
	Pounds / Gallon	7.5
	Cone Penetration, mm	
	Worked, 60 Strokes	285
	Timken OK Load, lbs	100
	Four Ball EP Test	
	Load Wear Index, kg	65.2
	Weld Point, kg	400
	Four Ball Wear Test	
	Scar diam, mm, 40k	
	1200 rpm, 165°F, 1hr.	<0.6
	Copper Strip Corrosion	1A
	Water Spray Off, %	<5.0
	Oil Separation (FTMS 791B, M 321.2)	<5.0
	Salt Spray	
	100 °F / 20% Salt (NaCl), 360+ Hours	Pass

* Properties are typical and may vary.



DURALEC™



Duralec from Royal Purple is a complete line of high performance lubricants specifically developed for all of your fleet vehicle needs. Duralec Commercial products are the most advanced lubricants in the market today.

DURALEC SUPER MOTOR OIL

Duralec Super motor oil is a high performance synthetic engine oil made for those diesel engines requiring the use of an emissions compliant oil for the 2007 and 2010 emissions equipment such as: DPF's, Catalytic Converters, EGR, and SCR injection with the ultra low sulfur diesel fuels found in North America and Europe.

Duralec Super motor oil is specifically formulated to maximize component life, extend drain intervals and improve fuel performance with excellent high temperature break down resistance and low temperature pumpability to minimize cold-induced startup wear.

PERFORMANCE ADVANTAGES

- Greater wear protection
- Greatly extends oil drain intervals
- Superior corrosion protection
- Reduces exhaust emissions
- Keeps engines clean
- API warranty compliant
- Will not harm seals



PART NUMBERS

Duralec 5W-40	5-Gal. Pail	85540
	1-Gal. Bottle	83540
Duralec 10W-30	5-Gal. Pail	85130
	1-Gal. Bottle	83130
Duralec 15W-40	5-Gal. Pail	05154
	1-Gal. Bottle	04154
	1-Qt. Bottle	01154

DURALEC™





FAQS

Get the answers to frequently asked questions about our most popular products.

MOTOR OILS

What is the difference between HPS and Royal Purple API-licensed motor oils?

Royal Purple API-licensed motor oil is formulated specifically to meet current American Petroleum Institute (API)¹, International Lubricant Standardization and Approval Committee (ILSAC), and Association des Constructeurs Européens d'Automobiles (ACEA) specifications for new vehicle warranties. Over the last several years, these specifications have become increasingly restrictive on certain additives, particularly those commonly used for anti-wear. As such, API/ILSAC compliant oils aren't the best solution for consumers that have modified their vehicles or those simply looking for the greatest performance.

HPS is formulated with consumers in mind. This motor oil line offers the incredible performance and protection provided by Royal Purple's proprietary Synerlec technology as well as a dramatically enhanced anti-wear package. HPS is also the choice for those seeking to maximize horsepower and torque, while reducing wear, heat and fuel consumption. HPS is the most robust engine oil Royal Purple makes for non-racing applications.

Will HPS harm my catalytic converters?

No. Testing has shown no short or long term adverse effects on catalysis in mechanically sound vehicles.

Can I use HPS in my diesel engine?

Absolutely. All viscosities of HPS, excluding 5W-20, are formulated for use in gas and/or diesel engines and as such are ideal for those with modified diesels or those simply looking for more performance out of their diesel.

Are Royal Purple oils compatible with other motor oils?

Yes. Royal Purple lubricants are fully compatible with mineral or synthetic oils. No special procedures are necessary when switching to Royal Purple.

Can your motor oil be used in older engines?

Yes. Mileage and/or age is not a factor when used in a mechanically sound engine. In high-mileage applications, we do recommend running a minimum of two short 3,000 mile (5,000 km) intervals before extending the oil drain intervals. This will enable Royal Purple's high solvency to remove existing deposits gradually; if excessive, such deposits can restrict oil flow, as well as reduce the oil service life significantly.

Can I use Royal Purple in my brand new car?

Yes. Royal Purple currently offers many viscosity grades of API-licensed motor oils¹. To allow for proper break-in of the engine, Royal Purple recommends waiting until the manufacturer's first scheduled oil change or a minimum of 2,000 miles (3218 km) in new gasoline engines. Allow a minimum of 6,000 miles (9656 km) before using Royal Purple in diesel engines.

¹ API (American Petroleum Institute)

How many miles can I go between oil changes in vehicles that use gasoline?

Royal Purple suggests adhering to manufacturer's recommended oil change intervals for vehicles under warranty using Royal Purple API-licensed SAE motor oils. With Royal Purple HPS, drain intervals may be extended to 15,000 miles (20,000 km) or one year, whichever occurs first in street-driven, mechanically-sound vehicles.

How many miles can I go between oil changes in vehicles that use diesel engine oil?

Royal Purple suggests adhering to manufacturer's recommended oil change intervals for vehicles under warranty. Vehicles no longer under warranty using Royal Purple 15W-40 diesel engine oil can extend oil change intervals up to 15,000 miles (24,140 km) or one year, whichever occurs first in street-driven, mechanically-sound vehicles.

Is Royal Purple synthetic motor oil?

Yes. Royal Purple Motor Oils are composed of a proprietary formulation of synthetic base oils and synthetic additives containing iso-paraffinic diluents.

Royal Purple Break-in oil is the only non-synthetic automotive engine oil offered by Royal Purple.

Will synthetic oil cause my engine to leak or consume more oil?

Properly formulated synthetic oils will generally not cause an engine oil leak. Synthetic oils possess a higher degree of natural solvency, which can clean and remove deposits left by previous oils. The removal of extensive oil deposits can expose marginal or damaged oil seals, which may then leak. If an engine currently has excessive oil consumption (i.e. greater than 1 quart / 1,000 miles) the recommended course of action is to solve the oil consumption problem before switching to a synthetic.

Should I use an oil additive with Royal Purple?

No. We strongly recommend against using any oil additives as do most automotive manufacturers. Engine oils are formulated with a fine balance of additives (anti-foam, corrosion inhibitors, anti-wear, detergent / dispersants, oxidation inhibitors), and more is not necessarily better. The use of an oil additive could upset the balance resulting in reduced performance.

Does Royal Purple maintain its purple color after it's put into service?

No. The dye that's used to color the oil dissipates shortly after being put into service. The oil will appear brown at some point.

MOTOR OILS

Do your motor oils contain zinc/phosphorus?

Yes. All Royal Purple engine oils contain the zinc/phosphorus compound zinc dialkyl dithiophosphate (ZDDP), but the maximum amounts are restricted by the current API oil specifications. For stock, non-performance automotive street applications, API SN licensed oils are OK. For better wear protection, Royal Purple HPS and XPR lines of engine oils are formulated with a higher concentration of the zinc and phosphorus anti-wear additive and are suitable for ALL flat tappet and roller tappet camshaft valve trains.

Can your oil be used with flat tappet cams?

Yes. For stock, non-performance valve trains, Royal Purple SAE oils (API SN and ILSAC GF-5 licensed) are OK. For upgraded performance flat tappet camshafts, and vintage high performance engines, we recommend our HPS or XPR engine oils.

Is a special oil filter required when using Royal Purple?

While no special oil filter is required, we do recommend upgrading to a high quality oil filter. A high quality filter will prevent contaminants from circulating through the system and causing damage.

Royal Purple now offers extended life oil filters. See our oil filter information page for more details or visit our dealer locator to find the dealer nearest you that carries our new filters.

Is HMX different from your SAE/API engine oils?

Yes, HMX is fortified with Royal Purple's proprietary Synerlec additive technology as well as additional seal conditioners beneficial to higher mileage engines to maintain elasticity of gaskets and seals. Further, HMX is formulated with a modified detergent/dispersant package and will possess greater ability to neutralize acids and corrosion.

Why should I use a high mileage oil?

A properly formulated High Mileage oil like HMX will reduce oil consumption and restore lost power. HMX is chemically enhanced to revitalize hardened seals reducing oil consumption common in higher mileage engines.

OIL FILTER

Are Royal Purple Filters compatible with all conventional and synthetic oils?

Yes. All Royal Purple Premium Oil Filters are compatible with both types of motor oils.

Do Royal Purple Filters meet all original equipment requirements and vehicle warranty?

Royal Purple Filters meet or exceed original equipment manufacturers' requirements. All new car warranties remain in effect when using Royal Purple Filters.

How does the quality of Royal Purple Filters compare with other manufacturers'?

Royal Purple Premium Filters use 100% synthetic micro-glass media for superior particle removal with 99% filtration efficiency at 25 microns and larger, and 80% of particles 10 microns and larger.

What is the recommended change interval?

Vehicles under warranty should follow the vehicle manufacturer's recommended change intervals. Vehicles no longer under warranty and in good condition may extend filter changes to 12,000 miles (20,000 km) if they are driven under normal operating conditions and are using Royal Purple motor oil or another major brand of synthetic motor oil. Vehicles using a diesel oil filter no longer under warranty and in good condition may extend filter changes to 15,000 miles (24,140 km) if they are driven under normal operating conditions and are using Royal Purple motor oil or another major brand of synthetic motor oil. Vehicles driven in severe conditions should follow the change intervals recommended in their owner's manual; severe conditions are defined as racing or commercial applications, frequent towing or hauling, extremely dusty or dirty conditions, or excessive idling.

What is the efficiency rating and at what micron size?

The efficiency of a filter is described in terms of a percentage of particles caught at a certain particle size (and larger). Using the ISO 4548-12 multi-pass filtration efficiency test, Royal Purple filters are:

-99% at 25 micron and larger

-98.7% at 20 micron and larger

-80% at 10 micron and larger

What function does the wire-backed media provide?

The wire backing is to support the filtration media. This further reduces the chance that the filter media could collapse. The use of stainless steel wire provides a strong, durable, AND low restriction way to provide the support.

Are all Royal Purple Premium Oil Filters constructed with a silicone anti-drain back valve? Why silicone?

Yes, the silicone anti-drain back valve prevents dry starts by preventing oil drain-back during shutdown. Silicone outperforms and outlasts standard rubber in both extreme cold and hot oil temperatures.

OIL FILTER

What are the beta ratios?

Average beta rating based on ISO 4548-12 multi-pass test methods:

B100 = 25 (at 25 or greater micron, media is 99% efficient.)

B75 = 20 (at 20 or greater micron, media is 98.7% efficient.
Also considered absolute rating.)

B5 = 10 (at 10 micron or greater, media is 80% efficient.)

MOTORCYCLE OILS

What viscosity is recommend for motorcycles?

Follow the manufacturer's recommendations regarding viscosity. Most manufacturers recommend a 10W-40 for 4-cycle, liquid-cooled motorcycles. Air / oil cooled motorcycles typically specify a 20W-50.

How many miles can I go between oil changes?

Royal Purple suggests adhering to manufacturer's recommended oil change intervals for vehicles under warranty. Vehicles that are no longer under warranty can frequently double or triple the number of miles between oil changes depending on the vehicle, its condition, the way it's used (excessive idling), and the oil filter that is used.

What product do you recommend for 2-cycle gearboxes?

For motorcycle 2-cycle and 4-cycle gearboxes with a separate reservoir, Synchromax manual transmission fluid or Max-Cycle 10W-30 is recommended.

What do you recommend for the primary case and transmission?

Royal Purple Max-Cycle 10W-30, 10W-40 or 20W-50 motor oil may be used in the primary tank. For transmissions, Royal Purple recommends Max-Cycle 20W-50 or Max Gear 75W-90. NOTE: DO NOT use Max Gear lubricants in the primary or in any other component containing a wet clutch.

What oil do you recommend for Harley Davidson motorcycles?

For Evolution and Twin Cam motors, Royal Purple Max-Cycle 20W-50 is recommended. If the owner's manual lists a 10W-40 or 15W-40, Max Cycle 10W-40 may also be used.

Will Royal Purple Max Cycle cause my clutch to slip?

No. Royal Purple provides exceptional film strength for excellent metal-to-metal protection. Royal Purple Max Cycle oils are rated JASO MA2 for wet clutch compatibility.

MOTORCYCLE OILS

I notice a strange odor when running Max-Cycle in my Harley. Is this normal?

Yes. Royal Purple uses a different additive chemistry than most manufacturers, which is the very foundation of the benefits RP offers. This technology has a distinctive odor, different from the common odor of exhaust gases to which most have become immune.

2-CYCLE OILS

Can I use Royal Purple to pre-mix with alcohol, methanol or nitro-methane?

No. Royal Purple's 2-cycle oils are formulated for use in gasoline applications only.

What product do you recommend for oil injected engines?

HP 2-C is recommended for most stock oil-injection applications. For cold weather oil-injection applications, Snow 2-C is recommended.

What product do you recommend for pre-mix in my 2-cycle engine?

HP 2-C may be used in pre-mix applications.

What product should I use in my oil-injected snow machine?

For low temperature, oil-injected applications, Royal Purple Snow 2-C is recommended.

Does Royal Purples 2 cycle oil void a new engine Warranty?

Royal Purple HP 2-C meets the performance requirements of any 2-stroke gasoline engine; however it does not carry any OEM oil licenses.

RACING OILS

Can I use racing oils in my street car?

Yes. Royal Purple XPR racing oils are fully formulated engine oils with complete additive packages needed for long-term use. XPR's ultra-light viscosities, XPR 3.1 and 0W-10 are typically only suitable for dedicated competition engines that are built to use low viscosity engine oils. Non-ultra light viscosities, XPR 5W-20, 5W-30, 10W-40 and 20W-50 may be used in street driven and daily driver applications, street and track duty vehicles and dedicated competition applications with gasoline or exotic fuels. Please note: Royal Purple XPR racing oils do not conform to API and/or ILSAC licensing requirements and should not be used when manufacturer's warranties are an issue.

RACING OILS

Can I run your oils with exotic fuels (alcohol, methanol, etc.)?

Yes. Royal Purple's lubricants can be used with exotic fuels. For the best protection, Royal Purple has formulated its XPR specifically with this in mind. The XPR oils are formulated to combat fuel emulsification to hold up even better than Royal Purple's other engine oils in alcohol and methanol applications. Royal Purple Nitro Plus oils are the best choice for blown alcohol, Nitro-methane and any other race application with excess fuel dilution. Royal Purple's other synthetic engine oils will still perform better than conventional racing oils; however, significant fuel dilution will reduce the effectiveness of these oils much more than the XPR and Nitro Plus oils.

How will running your product affect my oil temperature?

In most cases, vehicles with properly functioning cooling systems can reduce oil temperatures by 5-20°F by using Royal Purple.

What is the difference between your SAE motor oils and your racing oils?

Royal Purple's motor oils are formulated to provide unparalleled performance and protection and comply with API / ILSAC specifications. Its racing oils vary in viscosity and formulation as compared to the SAE motor oils to provide the greatest performance gains possible without regard to API, SAE and / or ILSAC specifications.

Is it true that your oils lose their performance edge after six or eight passes? (Drag Racing)

No. Royal Purple has not found any evidence that it shows deterioration in performance after being subjected to race conditions. It is possible that fuel dilution contamination may start to hinder the performance of the engine oil; however, dyno results do not support this claim.

MARINE OILS

How do I determine what viscosity to use, if I do not have an owner's / operator's manual?

Most all 4-stroke gasoline marine engines recommend a multi-viscosity 30 or multi-viscosity 40 weight engine oil. The most common is the 40 weight with the most common exceptions being Honda and Suzuki outboard motors.

How often should I change my oil in my boat engine using Royal Purple?

After the first 1 - 2 oil changes with the Royal Purple HPM motor oil, we recommend up to 3 times the hours listed in the owner's / operator's manual, or 12 months, whichever comes first.

How often should I change my lower unit oil using Royal Purple?

Assuming there is no contamination from foreign substances, we recommend up to 3 times the hours or time listed in the owner's / operator's manual, whichever comes first.

I noticed that HPM engine oils can be used in place of several viscosity grades of oil. Which one is right for my engine?

HPM oils are intended for 4-stroke, gasoline marine engines. If the factory recommends 10W-30 or SAE 30, Royal Purple HPM 10W-30 is the best choice. If the factory recommends 10W-40, 15W-40, 20W-40 or 25W-40, Royal Purple HPM 10W-40 is the best choice.

How can I tell if HPM 80W-90 gear oil is right for my lower unit/outdrive?

When looking at a SAE gear oil viscosity grade, the last number is most important. If the factory recommends 75W-90, 80W-90, or SAE 90 (straight 90 weight) gear oil, Royal Purple HPM 80W-90 will work great in your lower unit/outdrive.

What fuel-oil ratio should be used with HP 2-C?

We recommend starting with the ratio recommended by the equipment manufacturer. Typically this can be leaned-out a little, but it is highly equipment specific.

I have a 2-stroke outboard engine. Can I use HPM engine oil?

For 2-stroke engines, we recommend Royal Purple HP 2-C 2-cycle oil. It works great in pre-mix or oil injected applications. For pre-mix, we recommend using the manufacturer recommended mix ratio.

TRANSMISSION & GEAR OILS

Can I use your Max ATF in my transmission?

Check your owner's manual for verification. A complete list of warranty applications can be found on page 28.

My vehicle has a limited-slip differential. Do I need to add additional friction modifiers when using your Max Gear?

No. All viscosities of Max Gear are formulated with hypoid friction modifiers necessary for use in clutch or cone differentials. No additional additives are necessary.

My vehicle's transmission specifies an API GL-4 gear oil. Can I use Max Gear?

Yes. Max Gear is completely non-corrosive to soft yellow metals (brass, bronze, copper) so it is synchronizer-safe like a GL-4 gear oil. However, because of Royal Purple's proprietary Synerlec additive technology, Max Gear oils retain the load carrying and shock protection capability of a GL-5 gear oil.

FUEL ADDITIVES

What happens when fuel breaks down?

It forms non-combustible gums that form deposits in fuel systems / combustion chambers, which decreases engine performance / fuel economy and increases emissions.

Will Max-Clean rejuvenate old fuel?

No, but it will prevent it from breaking down any further, and allow it to be safely used without forming engine deposits.

How long does Max-Clean stabilize fuel?

Fuel can be stabilized to 1 year for gasoline/ethanol blends up to E15, and to 9 months for higher ethanol concentrations like E85.

With what fuels does Max-Clean work?

Gasoline, ethanol, diesel, and biodiesel.

Can Max-Clean be used in modern, fuel injected engines?

Yes, it will not harm catalytic converters or oxygen sensors, and will clean/remove deposits in port injected, direct injected, and carbureted engines.

How does Max-Clean remove deposits?

It contains polyetheramine (PEA), a proprietary detergent that solubilizes deposits so they can be burned during the combustion cycle in an engine.

Does Max-Clean increase octane?

No, but a cleaner burning engine has a reduced octane requirement, which allows less expensive, lower octane gasoline to be used without the risk of detonation.

FUEL ADDITIVES

What is the recommended treat rate for Max-Clean?

Pour entire contents of can into a nearly empty tank and refuel. One (1) can treats up to 20 gallons. For tank sizes outside of this range, use one (1) ounce per gallon. In two-cycle engines, use one (1) ounce per two (2) gallons. Royal Purple recommends using the 6 ounce can ever 3,000 miles (4,828 km) and the 20 ounce can every 10,000 (16,093 km).

What makes Max-Boost any better than other octane boosters?

Royal Purple Max-Boost provides up to 30 points (3 octane numbers) increase in fuel octane, which meets or exceeds the boost of any other consumer octane boosting product available, and it carries the added benefits of stabilizing fuel, cleaning deposits, and providing protection for non-hardened exhaust valve seats (lead substitute). It effectively replaces 2 to 4 products, depending on your needs.

How do I use Max-Boost?

Each 16 ounce can of Max-Boost treats between up to 25 gallons with maximum effective dosage at about 1 ounce of Max-Boost per gallon of fuel. To ensure best mixing with fuel, it is best to add Max-Boost to your fuel tank at fill-up, prior to putting the fuel into the tank.

Is Max-Boost a good product for any vehicle? Max-Boost is safe for use in any gasoline and gasoline/ethanol blend of fuel, but many non-performance cars do not benefit from high octane fuel. If the fuel stabilization and cleaning benefits of Max-Boost are what you want, rather than the increase in octane, we recommend Royal Purple Max-Clean Fuel System Cleaner & Stabilizer.

I have a [carbureted/throttle body injected/port injected/direct injected] performance engine. Will Max-Boost work for me?

Yes, Max-Boost works in any gasoline or gasoline/ethanol blend fuel delivery system and will work great for any engine that runs best with high octane fuel.

What makes Max-Tane any better than other diesel fuel treatments?

Royal Purple Max-Tane is better than any other consumer diesel additive because it does the job of every other consumer diesel fuel additive. Max-Tane is a cetane booster, a fuel lubricity enhancer, a fuel anti-gel, fuel system and injector cleaner and improves fuel economy up to 10%. Royal Purple Max-Tane effectively replaces up to 4 other diesel fuel additive products.

What types of fuels is Max-Tane intended for?

Royal Purple Max-Tane is formulated for use in any diesel-type vehicular fuel including #1 and #2 diesel, biodiesel, and ultra-low sulfur diesel fuels.

FUEL ADDITIVES

How do I use Max-Tane?

Royal Purple Max-Tane is available in 10 ounce and 20 ounce cans. Each 10 ounce can treats up to 50 gallons of fuel and each 20 ounce can treats up to 100 gallons of fuel. To ensure best mixing with fuel, it is best to add Max-Tane to your fuel tank at fill-up, prior to putting the fuel into the tank.

I have a high performance diesel engine. What is the best treat-rate (dose) of Max-Tane?

The minimum recommended treatment rate of diesel fuels with Max-Tane is (1) ounce for every (5) gallons of diesel fuel (10oz can treats 50 gallons; 20 oz can treats 100 gallons). Extra benefit can be obtained for high performance applications by increasing to the maximum effective treat-rate of (1) ounce of Max-Tane for every (2) gallons of diesel fuel (10oz can treats 20 gallons; 20 oz can treats 40 gallons).

What makes Max-Atomizer different than other fuel injector cleaners?

It is the only additive formulated specifically for direct injection gasoline (DIG) engines, and is the most concentrated PEA fuel injector cleaner available on the market today.

What is PEA?

It is polyether amine, a powerful detergent proven most effective at removing coked deposits found on injectors in DIG engines.

Should Max-Atomizer be used only in DIG engines?

No, it can be used with any type of injectors, including port injectors, and diesel injectors.

How does Max-Atomizer improve engine performance?

It cleans injectors and restores proper flow, which optimizes injector spray patterns and better atomizes fuel as it enters the combustion chamber.

Can Max-Atomizer be used in fuel with ethanol?

Yes, it can be used in any gasoline and ethanol blend (E5, E10, E15, E85, etc.), and it provides the additional benefit of ethanol stabilization.

How often should Max-Atomizer be used?

Every 3,000 miles, or as necessary to maintain/restore engine performance.

How is Max-Atomizer different than Max-Clean?

Max-Atomizer is a stand-alone fuel injector cleaner. Max-Clean offers the injector cleaning of Max-Atomizer and also provides cleaning of piston crowns and combustion chambers, fuel stabilization, and demulsification of water from ethanol-containing fuels.

COOLING SYSTEM ADDITIVES

Is Purple Ice compatible with other cooling system additives?

Purple Ice should not be used with other heat-transfer or cooling enhancing products or “water wetters”. If such a product has been used in the cooling system, the system should be drained and flushed with Royal Flush before using Purple Ice.

Purple Ice is compatible with cooling system additives intended to stop or slow leaks. Please note that such stop-leak products often typically put a coating on the interior surfaces of the cooling system, so the effects of Purple Ice may be diminished.

Is Purple Ice compatible with anti-freeze in my car?

Purple Ice is compatible with all current OEM/factory and major brand automotive anti-freeze. This includes traditional green ethylene glycols, as well as OAT/HOAT antifreezes (e.g. DexCool; Ford and Chrysler orange, gold, pink; European and Japanese OEM red, pink, etc.).

What water / antifreeze concentration is recommended when using Purple Ice?

Purple Ice may be added to any antifreeze / water mix; however, testing has shown higher water concentrations yield greater cooling benefits. While Purple Ice does contain corrosion inhibitors as well as lubricants to compensate for a lower antifreeze / water concentration, Royal Purple recommends using a concentration of antifreeze appropriate for the cold winter temperatures in your area because Purple Ice offers no freeze or boiling protection. The preferred coolant mix would contain a minimum of 20% antifreeze (offers 12°F protection) to provide a higher boiling point, and greater corrosion and deposit protection for the coolant, along with 1 to 2 ounces of Purple Ice per quart of coolant.

How much Purple Ice do I need to add to my cooling system?

When using Purple Ice with an antifreeze / water mix, Royal Purple recommends adding 1 ounce of Purple Ice per quart of cooling system capacity. For straight water (racing) applications, Royal Purple recommends adding 2 ounces of Purple Ice per quart of cooling system capacity.

How often should I add Purple Ice to my radiator?

When used with antifreeze, Purple Ice should be added once a year or every 30,000 miles (48,280 km), whichever comes first, in order to maintain proper performance. When using Purple Ice in a cooling system running straight water, Purple Ice should be added once a year or every 15,000 miles (24,140 km), whichever comes first.

COOLING SYSTEM ADDITIVES

Will adding too much Purple Ice harm my cooling system?

No, a higher concentration of Purple Ice than recommended will not harm the cooling system or engine. However, going well beyond 2 ounces of Purple Ice per quart of coolant won't offer any additional cooling benefit, but may result in some foam generation in the system.

Can Purple Ice be used in diesel engines?

Yes. Purple Ice may be used in diesel engines for improved heat transfer as well as reduced cavitation.

What is Royal Flush?

It is an engine cooling system flush and cleaner that maintains and restores cooling system efficiency. Using completely different technology than any other automotive cooling system flush and/or cleaner on the market, Royal Flush is a highly concentrated product that helps remove oils, scums, gels, slimes, corrosion byproducts, and other contaminants.

What problems does it solve?

Royal Flush maintains clean metal surfaces inside engines and radiators, which optimizes heat transfer.

How does Royal Flush work?

It cleans the entire cooling system, neutralizes acidic build-up, and restores cooling efficiency. It contains industrial-grade detergents that chemically "scrub" surfaces inside the cooling system to remove contaminants, plus solubilizing agents that help to keep gels in solution during the flushing process, facilitating more effective removal.

How is it different than other products?

Royal Flush is the only industrial-grade cooling system flush and cleaner on the market today. It is more concentrated than any other product, allowing it to be packaged in a more compact 12-ounce size. It is a one-step flush that contains no acids, and does not require use of a post-flush neutralizer. Royal Flush has a neutral pH and does not contain any acids and won't damage paint or finishes if splashing occurs while flushing.

PRODUCT RECOMMENDATIONS

GENERAL APPLICATIONS

This is a general outline.

AUTOMOTIVE

ENGINES

Gasoline	Royal Purple Motor Oils*
Diesel	15W-40
European Passenger Car & Small Diesel	0W-40 5W-40

TRANSMISSIONS

Automatic	Max ATF
Manual	Synchromax *
Heavy Duty Manual	Max Gear 75W-90 HPS 10W-30

POWER STEERING

Power Steering	Max EZ
----------------	--------

REAR ENDS

Heavy Duty	Max Gear 75W-90 Max Gear 85W-140
Light Truck & Passenger Car	Max Gear 75W-90 Max Gear 75W-140

4-CYCLE MOTORCYCLE

LIQUID-COOLED JAPANESE

Engine	Max-Cycle 10W-30 Max-Cycle 10W-40
Final Drive - Chain	Max-Chain
Shaft Drive	Max Gear 75W-90

LIQUID COOLED - EUROPEAN

Engine	Max-Cycle 10W-30 Max-Cycle 10W-40
Final Drive - Chain	Max-Chain
Shaft Drive	Max Gear 75W-90

4-CYCLE MOTORCYCLE, CONT.

AIR / OIL COOLED METRIC

Engine	Max-Cycle 20W-50
Max-Cycle 10W-40	
Final Drive - Chain	Max-Chain
Shaft Drive	Max Gear 75W-90

AIR / OIL COOLED DOMESTIC

Buell	
Engine	Max-Cycle 20W-50
Transmission	Max-Cycle 10W-30
H/D Sportster	
Engine	Max-Cycle 20W-50
H/D Evo / TwinCam	
Engine	Max-Cycle 20W-50
Transmission	Max Gear 75W-90

Max-Cycle 20W-50	
Primary	Max-Cycle 10W-30

Max-Cycle 20W-50

OFF-ROAD / DUAL SPORT: 2-C, 4-C

4-CYCLE

Engine	Max-Cycle 10W-30 Max-Cycle 10W-40
Transmission	
- Separate Tank	Synchromax Max-Cycle 10W-30 Max-Cycle 10W-40
Final Drive - Chain	Max-Chain
Final Drive - Shaft	Max Gear 75W-90

2-CYCLE

Engine	
Pre-mix	HP 2-C
Racing	
Oil Injection	HP 2-C
Transmission	Synchromax
Final Drive - Chain	Max-Chain

GENERAL APPLICATIONS

This is a general outline.

OFF-ROAD / DUAL SPORT: 2-C, 4-C, CONT.

AIR / OIL COOLED METRIC

Engine	Max-Cycle 10W-40 Max-Cycle 20W-50
Final Drive - Chain	Max-Chain
Final Drive - Shaft	Max Gear 75W-90

MX MOTORCYCLE & ATV: 2-CYCLE, 4-CYCLE

4-CYCLE

Engine	Max-Cycle 10W-30 Max-Cycle 10W-40
--------	--------------------------------------

Transmission - Separate Tank	Synchromax Max-Cycle 10W-30 Max-Cycle 10W-40 Max-Chain Max Gear 75W-90
Final Drive - Chain	
Final Drive - Shaft	
2-Cycle Engine	

Pre-mix and Oil-injection	HP 2-C
Transmission	Synchromax
Final Drive - Chain	Max-Chain
Shaft Drive	Max Gear 75W-90

PERSONAL WATER CRAFT

4-CYCLE

Engine	HPM 10W-30 HPM 10W-40 HPS 10W-30 HPS 10W-40
Outdrive/Lower Unit	HPM Gear 80W-90 Max Gear 75W-90

2-CYCLE

Engine Pre-mix and Oil-injection	HP 2-C
Outdrive/Lower Unit	HPM Gear 80W-90 Max Gear 75W-90

MARINE APPLICATIONS

BOATS

Inboard 4-Cycle Gasoline Engine	HPM 10W-30 HPM 10W-40 HPS 10W-30 HPS 10W-40 15W-40
4-Cycle Diesel Engine	

HPS 10W-40 Outdrive/Lower Unit	HPM Gear 80W-90 Max Gear 75W-90
-----------------------------------	------------------------------------

Outboard 4-Cycle Engine	HPM 10W-30 HPM 10W-40 HPS 10W-30 HPS 10W-40
----------------------------	--

2-Cycle Engine Pre-mix	HP 2-C
---------------------------	--------

Oil Injection Outdrive/Lower Unit	HP 2-C HPM Gear 80W-90 Max Gear 75W-90
--------------------------------------	--

SNOWMOBILE & SNOW MACHINE

4-CYCLE

Engine	Max-Cycle 10W-30 Max-Cycle 10W-40
Transmission/Chain Case	Synchromax* Max-Cycle 10W-30 Max-Cycle 10W-40

2-CYCLE

Engine Pre-mix	HP 2-C
-------------------	--------

Oil Injection Transmission/Chain Case	Snow 2-C Synchromax*
--	-------------------------

GENERAL MAINTENANCE

Pivots, Cables, Oiled Bearings Trailer (wheel brgs)	Maxfilm Ultra Performance Grease
---	--

PRODUCT RECOMMENDATIONS

HIGH PERFORMANCE & RACING APPLICATIONS

This is a general outline.

AUTOMOTIVE

ENGINES

Drag Racing*
HPS 10W-30
HPS 10W-40
HPS 20W-50
XPR 3.1
XPR 0W-10
XPR 0W-20
XPR 5W-20
XPR 5W-30
XPR 10W-40
XPR 20W-50

Midgets
XPR 5W-30
XPR 10W-40
XPR 20W-50

Sprint Cars
XPR 5W-30
XPR 10W-40
XPR 20W-50

Late Models*
HPS 10W-30
HPS 10W-40
HPS 20W-50
XPR 0W-30
XPR 5W-30
XPR 10W-40
XPR 20W-50

Road Racing*
HPS 10W-30
HPS 10W-40
HPS 20W-50
XPR 0W-30
XPR 5W-30
XPR 10W-40
XPR 10W-60
XPR 20W-50

Super Speedway
XPR 0W-20
XPR 10W-40

AUTOMOTIVE, CONT.

AUTO TRANSMISSIONS

Max ATF
Racing ATF

MANUAL TRANSMISSIONS

Max Gear 75W-90
Synchromax

DIFFERENTIALS

Max Gear 75W-90
Max Gear 75W-140

KARTS

ENGINES

2-Cycle
4-Cycle
HP 2-C
XPR 5W-20

CHAINS

Max-Chain

MARINE

ENGINES

2-Cycle
4-Cycle
HP 2-C
HPM 10W-30
HPM 10W-40
XPR 5W-30
XPR 10W-40

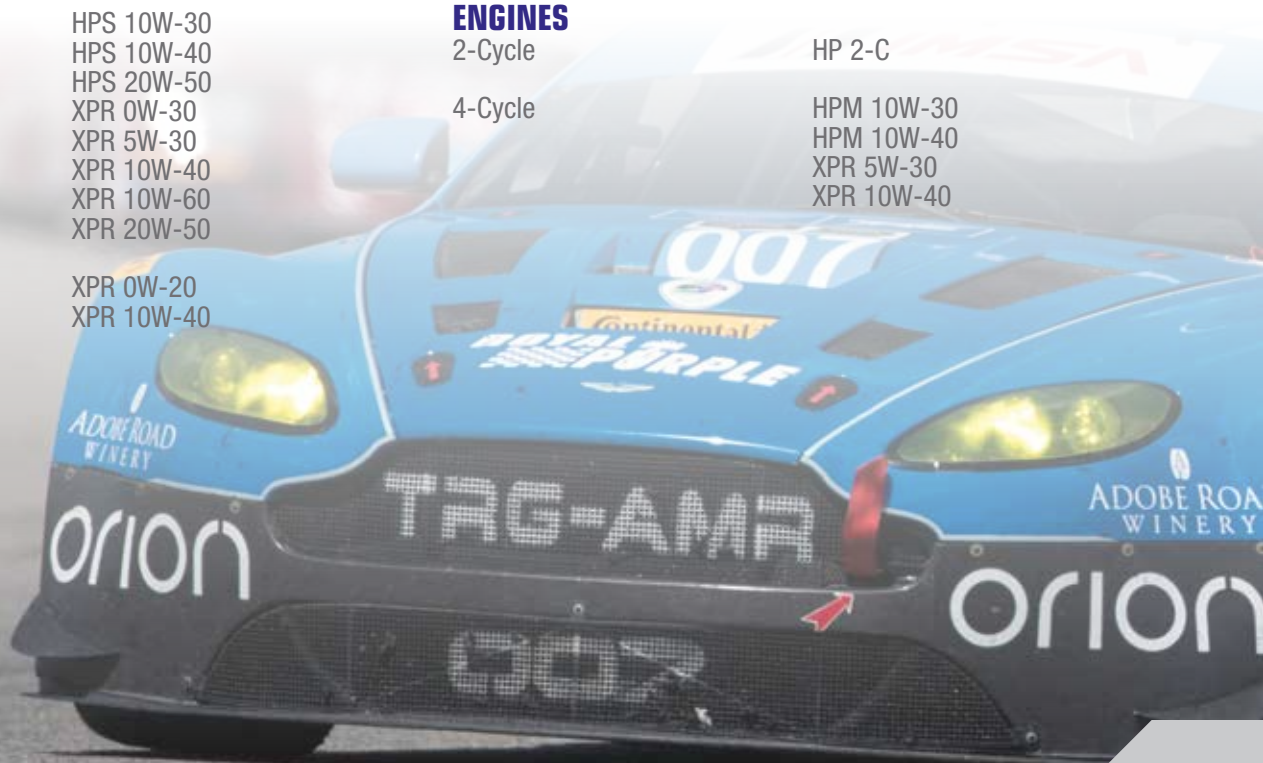

HIGH PERFORMANCE & RACING APPLICATIONS

This is a general outline. Always follow manufacturer's recommendations for oil viscosities.

MOTORCYCLE & ATV

ENGINES

2-Cycle	
Pre-mix and Oil-injection	HP 2-C
4-Cycle*	
- Gas	XPR 5W-20 XPR 5W-30 XPR 10W-40 XPR 20W-50
- Liquid-Cooled	XPR 0W-10 XPR 5W-20 XPR 5W-30 XPR 10W-40 Max-Cycle 10W-30 Max-Cycle 10W-40
- Air- / Oil-Cooled	XPR 20W-50 Max-Cycle 20W-50
- N2O & Exotic Fuel	XPR 5W-20 XPR 10W-40

TRANSMISSION

Separate Tank	Synchromax Max Cycle 10W-30 Max Cycle 10W-40 Max Cycle 20W-50 XPR 10W-30 XPR 10W-40 XPR 20W-50
---------------	--

FINAL DRIVE

Chain	Max-Chain
Shaft	Max Gear 75W-90

SNOW MACHINE

ENGINES

2-Cycle Pre-mix or Mod. Oil Injection	HP 2-C
2-Cycle Stock Oil Injection	Snow 2-C
4-Cycle	XPR 5W-20 XPR 5W-30 XPR 10W-40

TRANSMISSIONS / CHAIN CASES

Synchromax

***FOLLOW MANUFACTURER'S VISCOSITY RECOMMENDATIONS**



TRANSMISSION LUBRICANT CROSS REFERENCE

This is a general outline. Always follow manufacturer's recommendations.

TRANSMISSION	LUBRICANT SPEC / PART NUMBER	ROYAL PURPLE'S RECOMMENDATION
AUTOMATIC TRANSMISSION		
See Max ATF Specs Page 20		
MANUAL TRANSMISSION		
Manual Transmission/ Transaxle	Spec ATF's	Synchromax
Manual Transmission/ Transaxle	75W-90, 80W-90, 80W, 90W GL-4 or GL-5	Max Gear 75W-90
Manual Transmission/ Transaxle	75W-90, 80W-90 GL-3	HPS 10W-40 or XPR 10W-40
Bert & Brinn		Synchromax
Liberty & G-Force		Synchromax
APPLICATION	OEM SPEC # / PART #	ROYAL PURPLE RECOMMENDED
AUDI / VW	G-052-145	Max Gear 75W-90
BMW / MINI 1983 – 1992: Inspect for color coded label - typically affixed to passenger side of transmission	Green Label (Mobil SHC 630) Red Label (Dexron III) No Label (80W GL-4) 1993 – 1997 (Dexron III) 1998 & up (Mobil SHC 630) Esso MTF-LT-1, MTF-LT-2 MTF LT-3, MTF-LT-4 MTF-94 Castrol SAF-XJ (limited-slip) Castrol SAF-XO	Max Gear 75W-90 Synchromax HPS 5W-30 Synchromax Max Gear 75W-90 Synchromax Synchromax XPR 5W-20 Max Gear 75W-140 Max Gear 75W-90

TRANSMISSION LUBRICANT CROSS REFERENCE

This is a general outline. Always follow manufacturer's recommendations.

TRANSMISSION	LUBRICANT SPEC / PART NUMBER	ROYAL PURPLE'S RECOMMENDATION
APPLICATION	OEM SPEC # / PART #	ROYAL PURPLE RECOMMENDED
CHRYSLER / JEEP	75W-90 GL-3 04873167 04874459 04874464 04874465 04874469 05179014AA Mopar C635 DDCT Trans Fluid, 75W MS-9224 MS-9417 NV4500 5-spd (75W-85) Viper Trans, 1993 (DEX III) Viper Trans, 1994 –2006 (75W-85) Viper Trans, 2008 & up (ATF+4)	HPS 10W-40 Synchromax Max Gear 75W-90 Synchromax Synchromax Max Gear 75W-140 Synchromax Synchromax Synchromax Max Gear 75W-90 Synchromax Max Gear 75W-90 Synchromax
FORD MOTOR CO.	ESP-M2C166-H Mercon F32Z 19C547 XL-12 XT-2-QSM XT-5-QM XT-M5-QS XT-11-QDC	Synchromax Max Gear 75W-90 Synchromax Synchromax Synchromax HPS 10W-40 Synchromax
GENERAL MOTORS	SAE 80W-90 GM 1052931 GM 12345349 (Synchromesh) GM 12345577 GM 12346190 (SynTorque LT) GM 1235977 GM 12377916 (Synchromesh) GM 12378261 GM 12378396	Max Gear 75W-90 HPS or XPR 5W-30 Synchromax Synchromax Max Gear 75W-90 Max Gear 75W-90 Synchromax Max Gear 75W-90 Synchromax

TRANSMISSION LUBRICANT CROSS REFERENCE

This is a general outline. Always follow manufacturer's recommendations.

TRANSMISSION	LUBRICANT SPEC / PART NUMBER	ROYAL PURPLE'S RECOMMENDATION
APPLICATION	OEM SPEC # / PART #	ROYAL PURPLE RECOMMENDED
GENERAL MOTORS CONTINUED	GM 12378505 GM 12378508 GM 12378514 GM 12378515 GM 12378557 (QuadraSteer) GM 19256084 GM 19259104 GM 21018899 GM 88861800 GM 88862472 or 88862473 GM 88900402 GM 89021677 GM 89021806 GM 92184900 (Castrol SAF Carbon Mod) AutoTrak II BOT 0063 MTF 0063 Saab 12799117 Saturn 21005966 Saturn MTF VersaTrak fluid	Synchromax Synchromax Synchromax Synchromax Max Gear 75W-90 Synchromax HPS or XPR 5W-30 HPS or XPR 5W-30 Synchromax HPS or XPR 5W-30 Synchromax Max Gear 75W-90 HPS or XPR 10W-40 Max Gear 75W-90 Synchromax HPS or XPR 5W-30 HPS or XPR 5W-30 HPS or XPR 5W-30 Synchromax HPS or XPR 5W-30 Synchromax
HONDA / ACURA	Honda MTF # 08798-9031 Acura MTF # 08798-9031A Honda MTF # 08798-9016 Acura MTF # 08798-9016A	HPS or XPR 5W-30 HPS or XPR 5W-30 HPS or XPR 5W-30 HPS or XPR 5W-30
HYUNDAI	SAE 75W-85 (6-spd manual)	HPS or XPR 10W-40

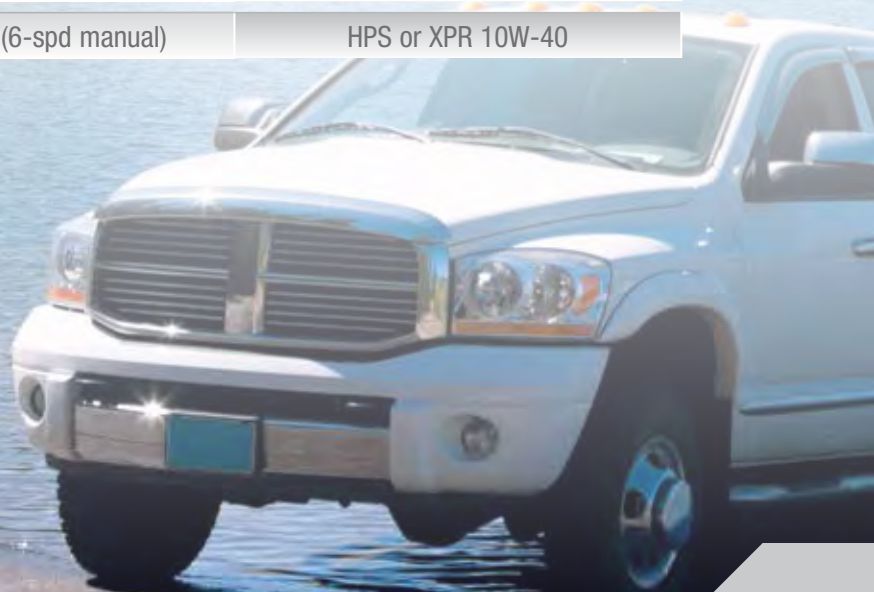

TRANSMISSION LUBRICANT CROSS REFERENCE

This is a general outline. Always follow manufacturer's recommendations.

TRANSMISSION	LUBRICANT SPEC / PART NUMBER	ROYAL PURPLE'S RECOMMENDATION
APPLICATION	OEM SPEC # / PART #	ROYAL PURPLE RECOMMENDED
JAGUAR / LAND ROVER	Shell TF 0753 Shell Spirax TS 90 Castrol SAF XO Castrol SAF Carbon Mod	Synchromax Max Gear 75W-90 Max Gear 75W-90 Max Gear 75W-90
MERCEDES BENZ / SMART CAR	MB 000 989 2603 MB 001 989 2603 MB 001 989 1703 (Hypoid Gear Oil) Shell ATF 3403 M115, MB 236.10, NAG1 Fuchs ATF 3353, MB 236.12 Castrol Manual BOT 328	Synchromax Synchromax Max Gear 75W-90 Max ATF Max ATF Max Gear 75W-90
MITSUBISHI	Texaco MTX Fluid FM	XPR 5W-20
NISSAN	Castrol SAF-XJ Nissan Trans Oil R35 Special	Max Gear 75W-140 Synchromax
PORSCHE	000 043 300 38 000 043 304 71 000 043 300 37 Castrol BOT 338 (75W-80) Shell Spirax S5 ATF (75W-90) Burmah Carbon Mod (75W-90)	Synchromax HPS or XPR 10W-40 Max Gear 75W-90 Synchromax HPS or XPR 10W-40 Max Gear 75W-90
TOYOTA	V-160, 08885-01306 (*93 & up Turbo Supra) Toyota Genuine LF Gear Oil	Synchromax Synchromax

PART NUMBERS

MOTOR OIL

HEAVY-DUTY

SAE 30	55-Gal. Drum	55030
	5-Gal. Pail	05030
	1-Qt. Bottle	01030
SAE 40	55-Gal. Drum	55040
	5-Gal. Pail	05040
	1-Qt. Bottle	01040
SAE 50	55-Gal. Drum	55050
	5-Gal. Pail	05050
	1-Qt. Bottle	01050

MULTI-GRADE

0W-20	55-Gal. Drum	55020
	5-Gal. Pail	05020
	5-Qt. Bottle	51020
	1-Qt. Bottle	01020
5W-20	55-Gal. Drum	55520
	5-Gal. Pail	05520
	5-Qt. Bottle	51520
	1-Qt. Bottle	01520
5W-30	55-Gal. Drum	55530
	5-Gal. Pail	05530
	5-Qt. Bottle	51530
	1-Qt. Bottle	01530
10W-30	55-Gal. Drum	55130
	5-Gal. Pail	05130
	5-Qt. Bottle	51130
	1-Qt. Bottle	01130
10W-40	55-Gal. Drum	55140
	5-Gal. Pail	05140
	1-Qt. Bottle	01140
	15W-40	55-Gal. Drum
5-Gal. Pail		05154
1-Gal. Bottle		04154
1-Qt. Bottle		01154

MOTOR OIL

20W-50	55-Gal. Drum	55250
	5-Gal. Pail	05250
	1-Qt. Bottle	01250
0W-40	1-Qt. Bottle	11484
5W-40	55-Gal. Drum	55540
	5-Gal. Pail	05540
	1-Qt. Bottle	01540

HPS – HIGH PERFORMANCE STREET OIL

HPS 5W-20	55-Gal. Drum	37520
	5-Gal. Pail	35520
	1-Qt. Bottle	31520
HPS 5W-30	55-Gal. Drum	37530
	5-Gal. Pail	35530
	1-Qt. Bottle	31530
HPS 10W-30	55-Gal. Drum	37130
	5-Gal. Pail	35130
	1-Qt. Bottle	31130
HPS 10W-40	55-Gal. Drum	37140
	5-Gal. Pail	35140
	1-Qt. Bottle	31140
HPS 20W-50	55-Gal. Drum	37250
	5-Gal. Pail	35250
	1-Qt. Bottle	31250

HMX – HIGH MILEAGE MOTOR OIL

HMX 5W-30	5-Qt. Bottle	11748
	1-Qt. Bottle	11744
HMX 10W-30	5-Qt. Bottle	11750
	1-Qt. Bottle	11746

RACING OILS

MULTI-GRADE RACING OILS

XPR 3.1 (0W-5)	55-Gal. Drum	55025
	5-Gal. Pail	05205
XPR 0W-10	55-Gal. Drum	55009
	5-Gal. Pail	05009
	1-Qt. Bottle	01009
XPR 0W-20	55-Gal. Drum	55008
	5-Gal. Pail	05008
	1-Qt. Bottle	01008
XPR 0W-30	55-Gal. Drum	55010
	5-Gal. Pail	05010
	1-Qt. Bottle	01010
XPR 5W-20	55-Gal. Drum	55011
	5-Gal. Pail	05011
	1-Qt. Bottle	01011
XPR 5W-30	55-Gal. Drum	55021
	5-Gal. Pail	05021
	1-Qt. Bottle	01021
XPR 10W-40	55-Gal. Drum	55041
	5-Gal. Pail	05041
	1-Qt. Bottle	01041
XPR 10W-60	55-Gal. Drum	55061
	5-Gal. Pail	05061
	1-Qt. Bottle	01061
XPR 20W-50	55-Gal. Drum	55051
	5-Gal. Pail	05051
	1-Qt. Bottle	01051

NITRO PLUS RACING OILS

Nitro Plus 50	55-Gal. Drum	55950
	5-Gal. Pail	05950
Nitro Plus 60	55-Gal. Drum	55960
	5-Gal. Pail	05960
Nitro Plus 70	55-Gal. Drum	55970
	5-Gal. Pail	05970

2-CYCLE OILS

HP 2-C	55-Gal. Drum	55311
	5-Gal. Pail	05311
	1-Gal. Bottle	04311
	1-Qt. Bottle	01311
Snow 2-C	55-Gal. Drum	55511
	5-Gal. Pail	05511
	1-Gal. Bottle	04511

MOTORCYCLE OILS

MAX-CYCLE

10W-30	1-Qt. Bottle	01314
10W-40	1-Qt. Bottle	01315
20W-50	1-Qt. Bottle	01316

MARINE OILS

HPM - FC-W (4-STROKE)

10W-30	1-Qt. Bottle	11582
10W-40	1-Qt. Bottle	11629

TRANSMISSION FLUIDS

AUTOMATIC

Max ATF	55-Gal. Drum	55320
	5-Gal. Pail	05320
	1-Qt. Bottle	01320
Racing ATF	5-Gal. Pail	10154

TRANSMISSION FLUIDS

MANUAL

Synchromax	55-Gal. Drum	55512
	5-Gal. Pail	05512
	1-Qt. Bottle	01512

PART NUMBERS

GEAR OILS

MAX GEAR

75W-90	55-Gal. Drum	55300
	15-Gal. Keg	16300
	5-Gal. Pail	05300
	1-Qt. Bottle	01300
75W-140	55-Gal. Drum	55301
	15-Gal. Keg	16301
	5-Gal. Pail	05301
	1-Qt. Bottle	01301
80W-90	55-Gal. Drum	55302
	5-Gal. Pail	05302
85W-140	55-Gal. Drum	55303
	15-Gal. Keg	16303
	5-Gal. Pail	05303
	1-Qt. Bottle	01303
SAE 90	55-Gal. Drum	55304
	5-Gal. Pail	05304

MARINE - HPM GEAR LUBE

80W-90	5-Gal. Pail	11689
	1-Qt. Bottle	11687

SPECIALTY LUBRICANTS

FUEL SYSTEM CLEANER AND STABILIZER

Max-Clean	20-Oz. Bottle	11722
	6-Oz. Bottle	11754

FUEL INJECTOR CLEANER

Max-Atomizer	6-Oz. Bottle	18000
--------------	--------------	-------

OCTANE BOOST & STABILIZER

Max-Boost	16-Oz. Bottle	11757
-----------	---------------	-------

DIESEL CETANE BOOSTER

Max-Tane	20-Oz. Bottle	11755
	10-Oz. Bottle	11756

POWER STEERING FLUID

Max EZ	12-Oz. Bottle	01326
--------	---------------	-------

COOLANT SYSTEM FLUSH

Royal Flush	12-Oz. Bottle	01650
-------------	---------------	-------

RADIATOR COOLANT ADDITIVE

Purple Ice	12-Oz. Bottle	01600
------------	---------------	-------

SPECIALTY LUBRICANTS

GUN OIL

RP Gun Oil	4-Oz. Can	10036
------------	-----------	-------

PENETRATING FLUID

Maxfilm	11-Oz. Can	05000
	4-Oz. Can	10035

CHAIN LUBRICANT

Max-Chain	4-Oz. Can	11407
-----------	-----------	-------

COMPRESSOR LUBRICANT

Synfilm Recip. 100	1-Gal. Bottle	04513
	1-Qt. Bottle	01513

ASSEMBLY LUBRICANT

Max-Tuff	8-Oz. Bottle	01335
	2-Oz. Bottle	10553

ENGINE BREAK-IN OIL

Break-In Oil	55-Gal. Drum	11511
	1-Qt. Bottle	11487

MULTI-PURPOSE GREASE

Ultra-Performance Grease	55-Gal. Drum	55312
	14.1-Oz. Tube	01312

DURALEC

MOTOR OIL

5W-40	5-Gal. Pail	85540
	1-Gal. Bottle	83540
10W-30	5-Gal. Pail	85130
	1-Gal. Bottle	83130
15W-40	5-Gal. Pail	05154
	5-Gal. Pail	04154
	1-Qt. Bottle	01154

OIL FILTER CROSS REFERENCE

MOBIL 1	FRAM	WIX	K&N	PUREONE	ROYAL PURPLE
M1-107	PH3506	51042	HP-1007	PL14006	10-44
M1-101	PH3387A	51040	HP-1001	PL10111	10-47
M1-113	PH10060	57060	HP-1017		10-48
M1-111	PH30, PH8873	51069, 57099	HP-1011, HP-2002	PL15313	10-454
M1-104	PH3593A, PH9688	51334	HP-1004	PL14459	10-2808
M1-102	PH3614	51348	HP-1002	PL10241	10-2835
M1-103	PH4967	51394	HP-1003	PL14476	10-2840
M1-110	PH7317	51356, 51357	HP-1010	PL14610, PL14620	10-2867
M1-108	PH6607, PH9715	51365	HP-1008	PL14622	10-2876
M1-213	PH9010	57302	HP-1014	PL15317	20-2009
M1-204	PH16	51085	HP-2004	PL14670	20-253
M1-209	HP10, PH3600	51516	HP-2009	PL20195	20-400
M1-212	PH10575, PH10590	57045, 57502	HP-2011, HP-7019	PL22500	20-500
M1-201	HP11, PH3980	51036	HP-2001	PL24011	20-51A
M1-205	PH2870A	51088, 51342	HP-2005	PL20252	20-561
M1-206	PH3675, PH9837	51522	HP-2006	PL25288	20-59
M1-210	PH2	57063, 51372, 57899	HP-2010	PL24651	20-820
M1-302	HP4, PH5	51060, 51061	HP-3002	PL34631	30-1218
M1-303	PH9100	57202	HP-3003	PL35399	30-2999
M1-301	HP1, PH8A, PH2815, PH3569	51333, 51452, 51515	HP-3001	PL30001	30-8A
M1-405	PH10890	57151			40-2051
M1-403	PH3976A	51607, 57620, 57620XE	HP-4003	PL45335	40-780
M1C-651	CH9549	57311, 57314	HP-7009	PL45515, PL45526	50-2017
M1-601	PH3786	51734	HP-6001	PL44872	50-2286

