

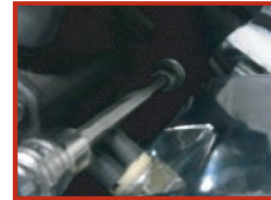

CLARITY TRANSMISSION COVERS



1. Turn off motorcycle, disconnect the battery, and place securely on a lift or sidestand.
2. **5spd models:** Some Softail models require removal of the oil tank and frame backbone to allow installation as well as the removal of the front starter bolt. Consult the HD service manual for specific instructions. Once accessible disconnect the neutral switch and remove the factory transmission cover.
6spd models: Simply remove the factory cover.



3. Once the existing transmission cover is removed, clean all gasket/mounting surfaces and wipe out all excess oil.
WARNING: DO NOT USE HARSH CHEMICALS SUCH AS BRAKE CLEANER OR ACETONE DURING CLEANING.
4. **5spd models:** Remove the transmission vent fitting/tube and the transmission neutral switch. These components will be reused.
6spd models: Remove the transmission vent fitting/tube. This will be reused.



5. Install the transmission vent fitting/tube into the RSD transmission cover using teflon tape or liquid thread sealant. Clock the vent fitting to match the factory position.
Note: 2007 6spd models use a threaded vent fitting and 08-up 6spd models use a push-in rubber vent tube.
6. **5spd models only:** Install the neutral switch into the RSD transmission cover.
7. Install the RSD transmission cover onto the transmission using the supplied gasket. Install bolts and torque to 105 in-lbs.

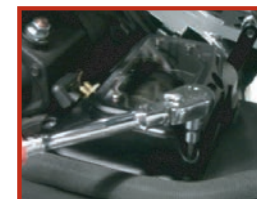

8. Reinstall any components that were removed for access and go for a ride.

PRODUCT DESCRIPTION

2007-LATER TWIN CAM MODELS (6SPD) including 06 DYNA MODELS 0203-2004

1987-2006 BIG TWIN MODELS (5SPD) except 06 DYNA MODELS 0203-2005

Caution: On some exhasut systems the Clarity Clutch Actuator can be very close to the exhaust. When installing, please verify there is an adequate distance of at least 5/16" between the Clarity window and the exhaust pipe to allow adequate air flow and cooling. Failure to verify the gap distance may result in severe damage to the Clarity windows, window discoloration, and potential oil leakage.

Disclaimer: Roland Sands Design is not responsible for damage caused by improper installation.



ROLAND SANDS DESIGN

CLARITY TRANSMISSION COVER

ASSEMBLY INSTRUCTIONS

WARNING:
 CLARITY WINDOW IS PERMANENTLY INSTALLED AT THE FACTORY AND SHOULD NOT BE REMOVED OR SERVICED. IF REMOVAL IS NECESSARY CONTACT THE TECH DEPARTMENT FOR SPECIAL SERVICE INSTRUCTIONS. PERFORMANCE MACHINE THE MANUFACTURER IS NOT RESPONSIBLE FOR DAMAGE TO THE CLARITY WINDOW CAUSED BY IMPROPER SERVICE.

0203-2004 (6SPD)

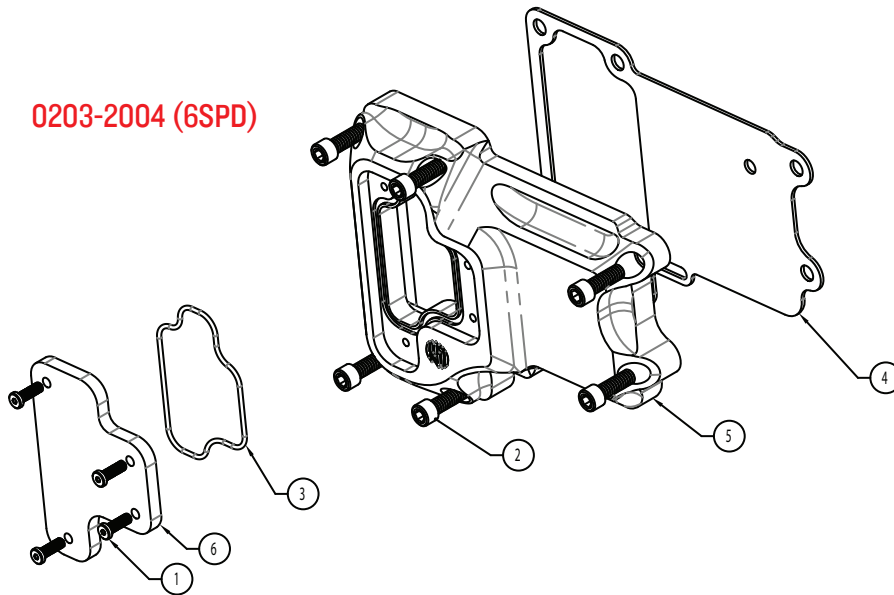

ITEM NO.	PART NUMBER	DESCRIPTION	QTY.
1	0101-9034-SS	SHCS LOW HEAD 8-32 X 1/2 W/ VIBRA-TITE	4
2	0101-1008-CH	SHCS 1/4-20 X 3/4 CHROME	6
3	0177-1025	MOLDED O-RING, CLARITY 6 SPEED TRANS COVER	1
4	0203-0009	GASKET 6 SPEED TRANS COVER, 07-09 ST, 07/09 FL, 06-09 DYNA	1
5	0203-0014	CLARITY 6 SPEED TRANS COVER, 07-09 ST, 07/09 FL, 06-09 DYNA	1
6	0203-0015	WINDOW, RSD CLARITY, 6 SPEED TRANNY, 07-12 ST, 07/12 FL, 06-12 DYNA	1

0203-2005 (5SPD)

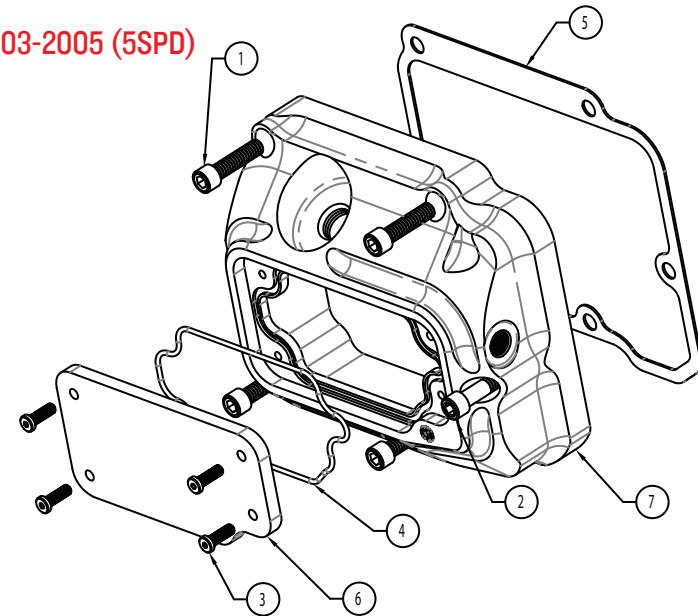

ITEM NO.	PART NUMBER	DESCRIPTION	Default Qty.
1	0101-1012-CH	SHCS 1/4-20 X 1 CHROME	4
2	0101-1022-CH	SHCS 1/4-20 X 1-3/4, CHROME	1
3	0101-9034-SS	SHCS LOW HEAD 8-32 X 1/2 W/ VIBRA-TITE	4
4	0177-1026	MOLDED O-RING, CLARITY 5 SPEED TRANS COVER	1
5	0203-0013	GASKET, RSD 5 SPEED TRANS COVER	1
6	0203-0016	COVER WINDOW, CLARITY 5 SPEED TRANS COVER	1
7	0203-0017	CLARITY 5 SPEED TRANS COVER, 00-06 FXST/FLST, 01-06 FLHT/FLHR/FLTR	1

Find out more about custom accessories & trim we have.