



Nostalgia Coil and Ignition Mount

Polished Stainless Steel hand built in the USA.
Relocates your stock HD coils and ignition to the "V" of the motor.

Fits: 2007-2010 Sportster
Part #: 0205-2009

Note: Upon assembly use blue 243 loctite on all fasteners

1. Turn your motorcycle off. Extinguish all cigarettes and open flames. If you've ever burned off your eyebrows you know it sucks.
2. Disconnect battery and remove existing HD coil and ignition (refer to HD manual)
3. Install Nostalgia Coil and Ignition Mount to the "V" of the motor with two 3/8-16x1-1/4 bolts (2), torque to 25 ft.lbs.
4. Re-route and extend coil and ignition wiring to new location and plug in.
5. Mount ignition to bracket using stock screw and lock washer, torque to 20 in. lbs.
6. Bolt coil to bracket using two 1/4-20x2-1/4 bolts (1), two spacers (3) and stock plate nut.
7. New trim to fit spark plug wires (Drag Specialties part# 7806-1556) are required to complete installation. Trim plug wires to desired length and install.
8. Cruise it.....

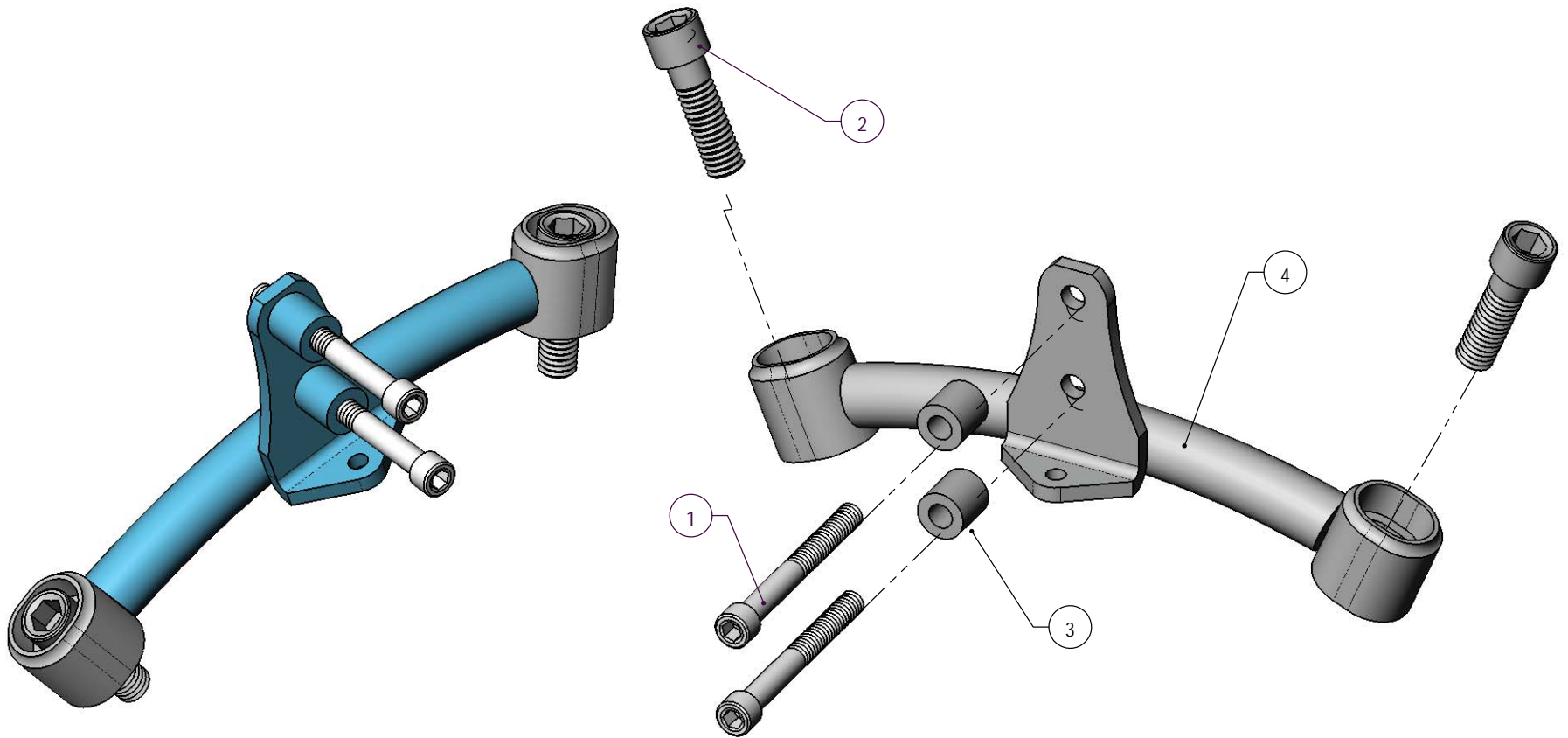

ITEM NO.	PART NUMBER	DESCRIPTION	QTY.
1	0101-1032	SHCS 1/4-20 X 2.25	2
2	0101-3009-CH	SHCS 3/8-16 X 1-1/4-CHROME	2
3	0205-0021	COIL SPACER,SPORTSTER 07-10	2
4	0205-1002	WELDED ASSY.,COIL AND IGNITION MOUNT	1