



CLARITY CAM COVER



PRODUCT DESCRIPTION

2001-2012 Twin Cam Models except 2001-2012 FL Touring models.

0177-2003

Warning: Will not fit 2001-2012 FL Touring models with stock and/or stock style exhaust pipes.

1. Turn your motorcycle off and disconnect the battery.
2. Place an oil pan underneath the cam cover area and remove the existing cam cover. (refer to the HD service manual if necessary). Removal of the exhaust system may be required on some models.
3. Once the existing cam cover is removed, clean all gasket/mounting surfaces and wipe out excess oil. **Note: Do not use any harsh chemicals such as brake cleaner or acetone during cleaning.**
4. Using supplied gasket, install the RSD Clarity Cam cover and hand tighten bolts to hold it in place. **NOTE: Upon assembly use blue 243 loctite on the 1/4" fasteners.**
NOTE: Make sure the inside of the Lexan window is clean prior to installation. Clean with Plexus if necessary.
5. Torque the 1/4-20 x 1" bolts to 105 in-lbs using the torque sequence shown in Fig A below.
6. Reconnect the battery and check the oil level. Add oil if necessary per the HD service manual.
7. Reinstall the exhaust system if necessary.

Caution: The Clarity Cam cover may interfere with some exhaust systems. When installing, please verify there is an adequate distance of at least 5/16" between the Clarity window and the exhaust pipe to allow adequate air flow and cooling. Failure to verify the gap distance may result in severe damage to the Clarity windows, window discoloration, and potential oil leakage.

Disclaimer: Roland Sands Design is not responsible for damage caused by improper installation.

8. Go for a ride!

CAUTION:

CLARITY WINDOW IS PERMANENTLY INSTALLED AT THE FACTORY AND SHOULD NOT BE REMOVED OR SERVICED. IF REMOVAL IS NECESSARY CONTACT THE TECH DEPARTMENT FOR SPECIAL SERVICE INSTRUCTIONS. PERFORMANCE MACHINE THE MANUFACTURER IS NOT RESPONSIBLE FOR DAMAGE TO THE CLARITY WINDOW CAUSED BY IMPROPER SERVICE.

USE ONLY LEXAN APPROVED CLEANERS SUCH AS PLEXUS TO CLEAN YOUR CLARITY WINDOW. HARSH CHEMICALS MAY CAUSE DAMAGE.

NOTE: FOGGING MAY OCCUR ON THE INSIDE OF THE LEXAN WINDOWS DUE TO HUMIDITY CHANGES. IF FOGGING IS VISIBLE START THE MOTORCYCLE AND RUN UNTIL FOGGING DISAPPEARS.

Fig A

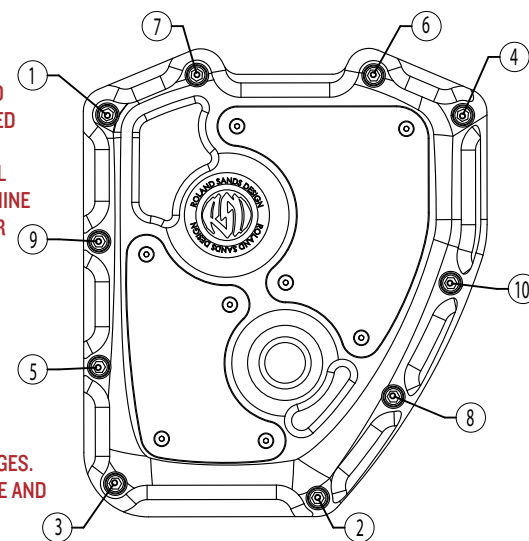



Clarity Cam Cover

Caution:
The Clarity Windows are preinstalled at the factory and should not be removed or serviced. If removal is necessary contact the tech department for special service instructions.

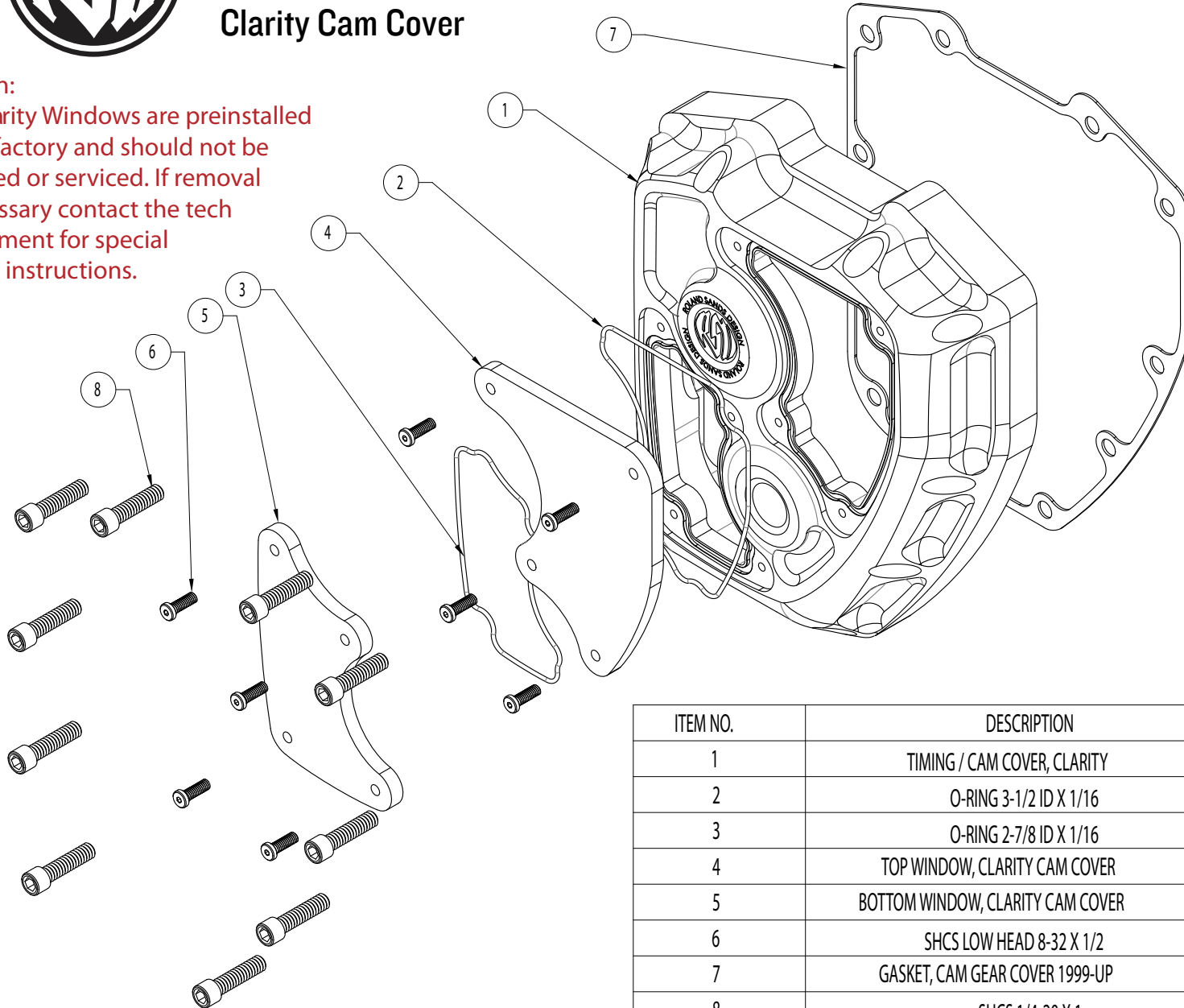

ITEM NO.	DESCRIPTION	QTY.
1	TIMING / CAM COVER, CLARITY	1
2	O-RING 3-1/2 ID X 1/16	1
3	O-RING 2-7/8 ID X 1/16	1
4	TOP WINDOW, CLARITY CAM COVER	1
5	BOTTOM WINDOW, CLARITY CAM COVER	1
6	SHCS LOW HEAD 8-32 X 1/2	8
7	GASKET, CAM GEAR COVER 1999-UP	1
8	SHCS 1/4-20 X 1	10



CLARITY CAM COVER

The RSD Clarity Cam Cover 0177-2003 contains two pre-installed Lexan polycarbonate windows. These windows are very resistant to almost everything a motorcycle will be exposed to, however, extra care and preparation must be taken when installing the cam cover near the exhaust system. The Lexan polycarbonate windows must be at least 5/16" away from the exhaust pipe to insure the temperature does not exceed the capabilities of the Lexan. Additional clearance is recommended to preserve the optical clarity of the Lexan window as well as reducing the amount of heat introduced to the engine from the exhaust. Take measurements when installing the exhaust system and make sure that the exhaust **NEVER** contacts the Lexan windows, bolts, or the aluminum cam cover. Lexan is very durable but it must be treated just like any plastic and cannot come into contact with the exhaust pipes. The Lexan windows just like any plastic will melt if in direct contact with the exhaust pipe. If the Lexan windows have less than adequate clearance premature discoloration, cracking, or melting may occur causing severe failure and/or possible injury to the rider. RSD recommends the use of "high pipes" or exhaust that runs above the cam cover which eliminates any potential exhaust contact.

TECHNICAL GUIDELINES FOR CLARITY CAM COVER:

1. THERE MUST BE AT LEAST 5/16" AIR GAP BETWEEN THE EXHAUST AND THE LEXAN WINDOWS, BOLTS, AND COVER.
2. ABSOLUTELY NO CONTACT BETWEEN THE LEXAN WINDOWS, BOLTS, OR ALUMINUM CAM COVER.
3. DO NOT USE BRAKE CLEANER, ACETONE, OR ANY HARSH CHEMICALS DURING INSTALLATION.
4. USE PLEXXUS CLEANER FOR CLEANING. IF ANY OTHER CLEANERS ARE USED READ THE LABEL TO VERIFY COMPATIBILITY WITH LEXAN.

PRODUCT DESCRIPTION

2001-2012 Twin Cam Models **except 2001-2012 FL Touring models.**

0177-2003

RSD/PERFORMANCE MACHINE LIMITED WARRANTY INFORMATION

Performance Machine warrants to the original purchaser that the parts of this cam cover to be free of manufacturing defects in materials and workmanship for a period of one (1) year from the date of purchase. In the event warranty service is required, you must call Performance Machine immediately with a description of the problem.

If it is deemed necessary for Performance Machine to make an evaluation to determine whether the part is defective, a return authorization number will be given by Performance machine. The parts must be packaged properly so as to not cause further damage and returned prepaid to Performance Machine with a copy of the original invoice of purchase and a detailed letter outlining the nature of the problem. If after the evaluation by Performance Machine the part was found to be defective it will be repaired or replaced at no cost to you. If we replace it, we may replace it with a reconditioned one of the same design.

Performance Machine shall not be held liable for any consequential or incidental damages resulting from the failure of a Performance Machine part.

Performance Machine shall have no obligation if a part becomes defective as a result of improper installation or abuse.

2000-08 FL MODELS: INADEQUATE CLEARANCE

-CONTACT WITH BOLT HEADS WILL CAUSE SEVERE LEXAN FAILURE!

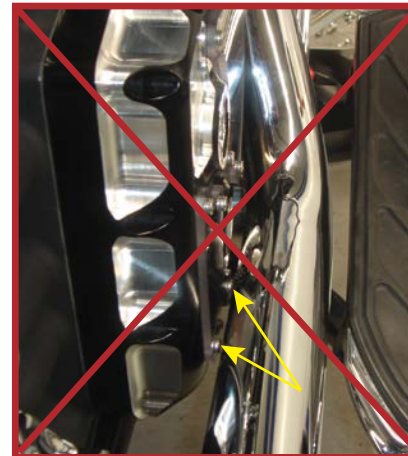

2009-12 FL MODELS: INADEQUATE CLEARANCE

-CONTACT WITH ALUMINUM HOUSING WILL CAUSE SEVERE LEXAN FAILURE!

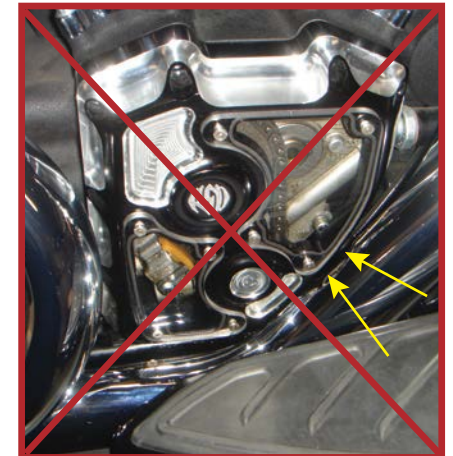

Warning: Contact may occur on Softail & Dyna models. Always check exhaust clearances during installation.