

LED MIRROR INSTALLATION INSTRUCTIONS

#MIRLED and #MIRLEDBK

This set of mirrors can be installed on any motorcycle where the original mirrors bolt to the handlebar switch housing/lever mounts

1. Remove the stock mirrors. Lay the new LED mirrors out: notice that one of the heads is upside down from the way it was packaged. Rotate this mirror ahead to be right side up so that the lettering is at the bottom of both mirrors.
2. On motorcycles where the mirror are secured with thru bolts from the bottom (Harley Davidson, Triumph, etc), install the LED mirrors using the supplied Allen screws and lock washers. Place a lock washer onto the screw, place the screw thru the mirror mounting hole from the bottom up and then thread the screw into the mirror.
3. If the motorcycle has optional or accessory chrome switch and master cylinder covers it may be necessary to place one or two washers between the mirror and the chrome cover to provide adequate clearance for the mirrors base or stem. On some older smaller and mid size Harley models, one or both of the turn signals mount to the bottom of the original mirrors stud. While very few models use this, we do have adaptors (Part # MIRLED-1) to use on this type of mount.
4. On metric motorcycles and other where the mirrors stem screws into a threaded hole on the switch housing you will need to use the supplied adaptors. Notice there is a third adaptor supplied with left hand threads marked with a small ring or notch machined around the long lock nut on the adaptor. This adaptor is only for the right hand mirror on Yamahas all others will use the two with right hand threads.
5. Remove the long hex nut from the adaptors you will be using noting the end closest to the 10mm hex on the adaptor stud has no threads inside it .Place a drop of thread locking compound (Loctite) onto the small end of the adaptor and thread the adaptor into the mirror then tighten securely (15 ft. lbs.) using the box or closed end of a 10mm wrench.
6. Place the long hex nut back onto the stud with end having no threads inside on first like it came off. Screw the nut on until it touches the base of the mirror then back it off two full turns (about a 1/8" gap). Screw the mirror/ adaptor assembly into the mirror mounting hole on the handlebar control as far as it will go or until it reaches the long lock nut being careful not to catch the wires or cross thread the adaptor into the hole as you rotate the assembly. While seated on the motorcycle, align or rotate the mirror to the desired position being sure to leave some range of motion in the ball and socket pivot on the backside of the mirror

for fine adjustments while riding. Tighten the long lock nut using a 14mm wrench to lock the mirror in position.

7. Route the mirror wires with the other wires and cables thru any retaining clips or ties to the turn signal wire connectors (usually inside the headlight shell) leaving enough slack for the handlebars to turn full left and right without pulling on the wires. On motorcycles that have bullet type wire connectors for the turn signals the connection can be made as follows: Strip back the mirror wires about $\frac{1}{2}$ ', unplug the bullet connector, place the striped wire inside the female bullet then plug the male into the female. On other motorcycles you may want to use 3-way crimp on splice connectors (not supplied).

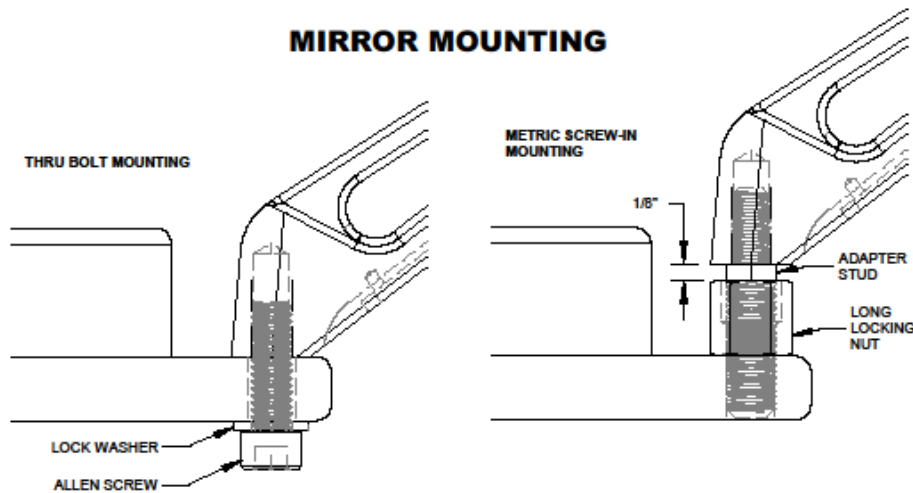

WIRING

There are three wiring diagrams included

Basic wiring diagram: this will apply to most motorcycles

90% of all motorcycles will only require this simple connection to the motorcycles existing turn signal wires.

CAN BUS wiring diagram: Victory, BMW and some others

These models will have a computerized type wiring system and you must connect our MIR100 CANBUS module (not supplied) between the motorcycles signals and the mirrors.

Indian wiring diagram: 2014 and newer Indian motorcycles

These models are wired the opposite of most with power being supplied to the signals constantly and the ground wire being switched on an off. This will require the use of 2 relays Rivco # RELAY (not supplied).

NOTE: If you are removing the original turn signals when installing these mirrors (We do not recommend this practice for obvious safety reasons) you will need to add a load equalizer of some type in line to each of the yellow wires. This is because the original signals draw much more current and the turn signal flasher was designed for this load. The LED mirrors draw very little current, usually causing them to flash rapidly when used without the original signals thus requiring a load equalizer to slow them down to the correct speed.

These are convex mirrors and objects seen in them are closer than they appear!

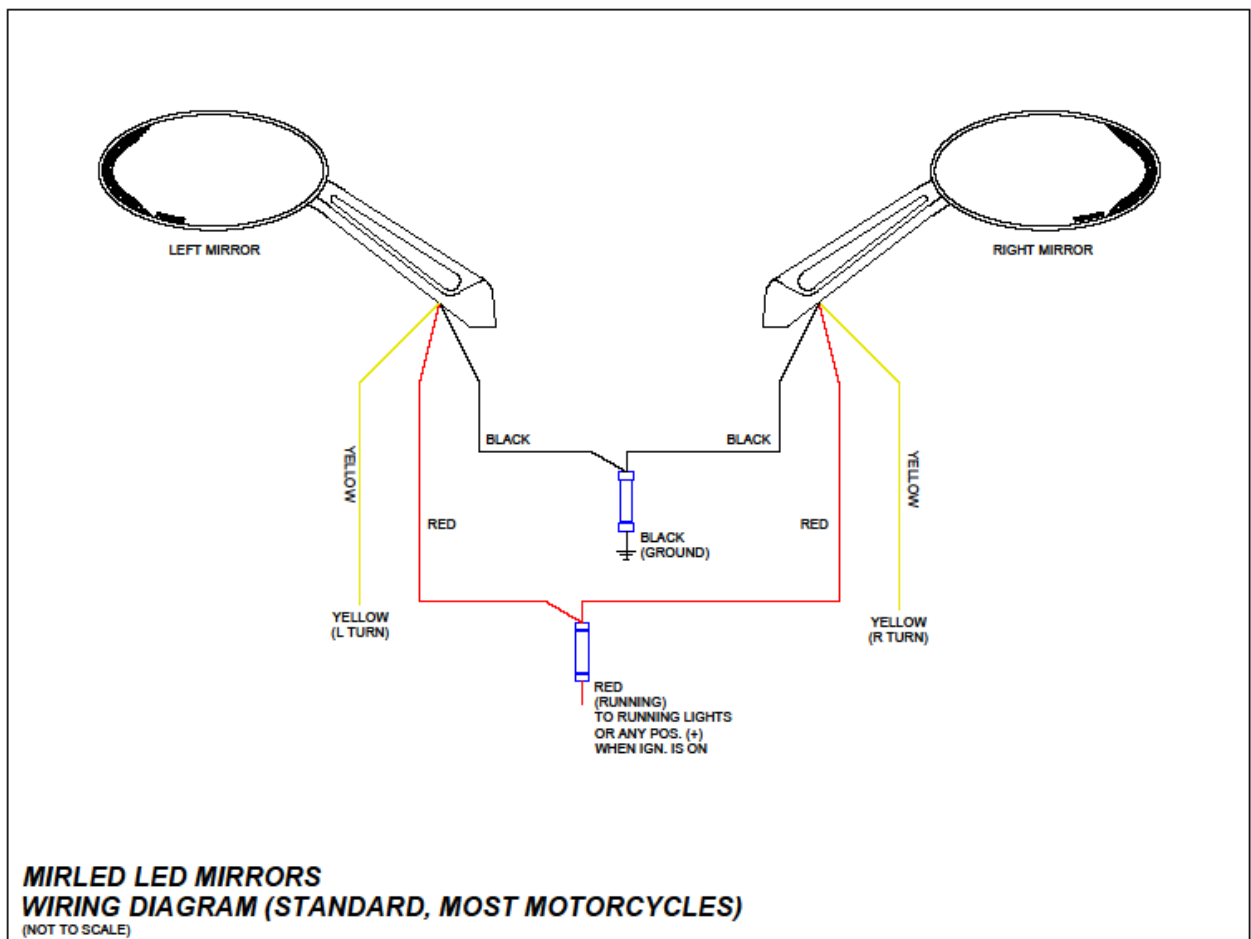

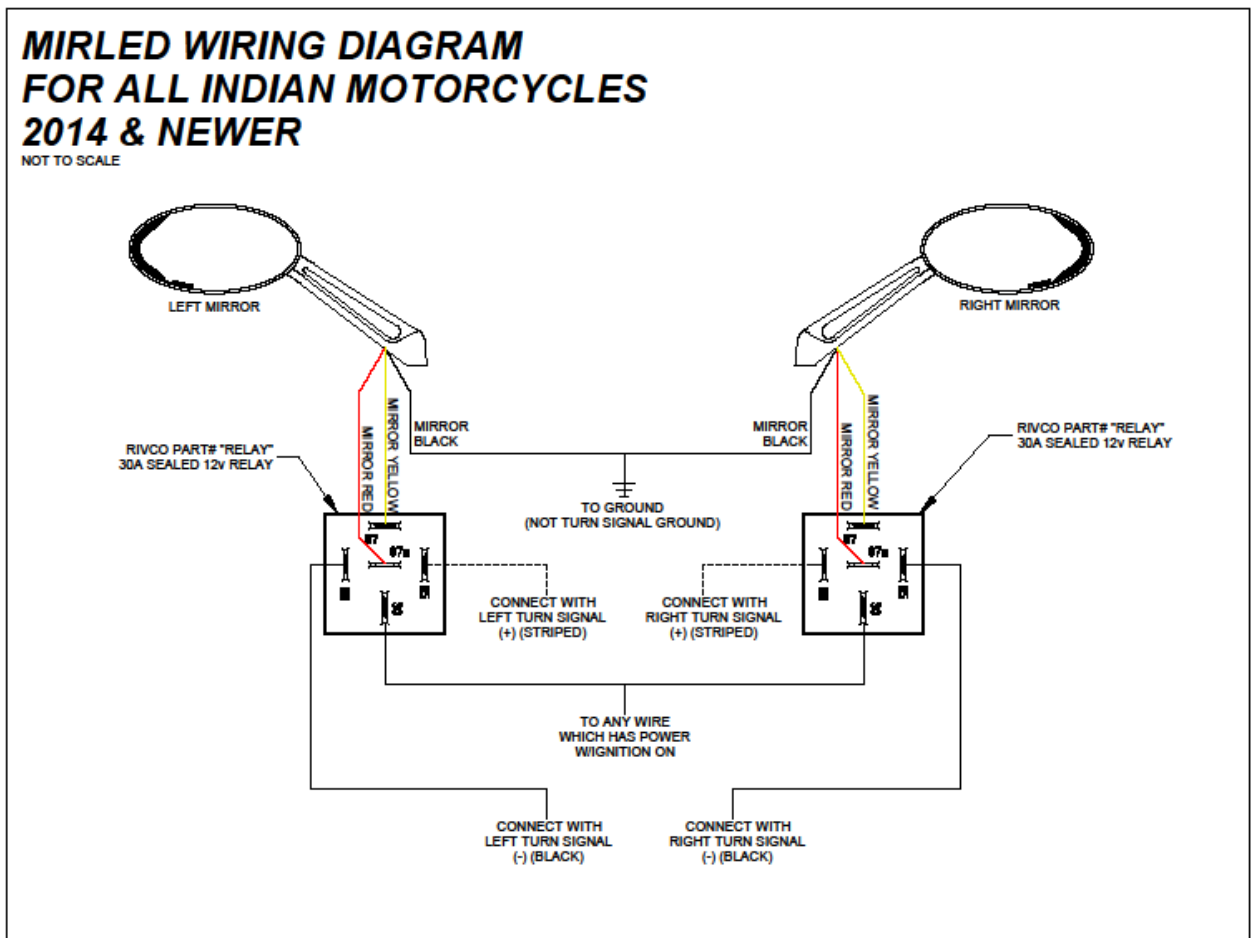
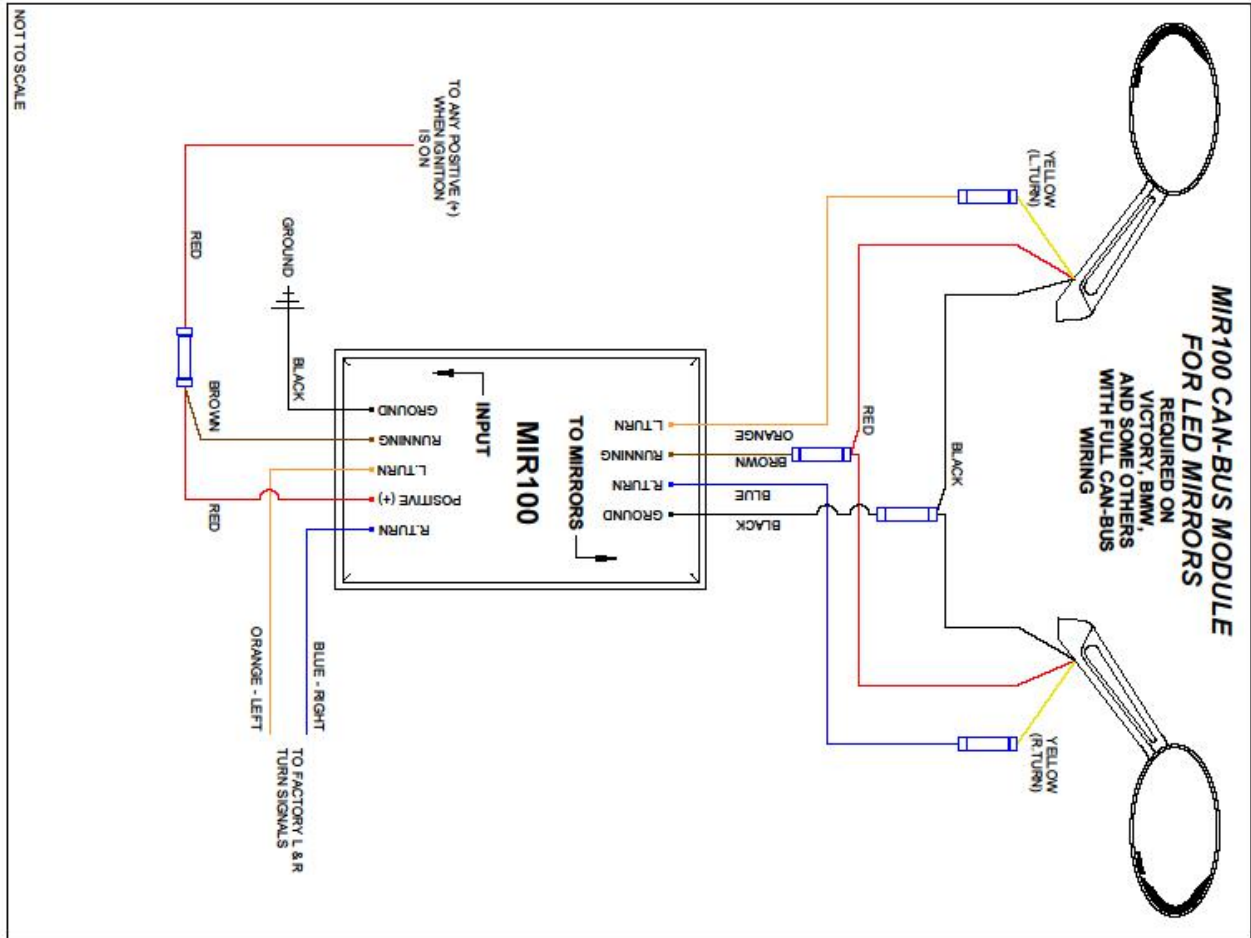

When it comes to quality motorcycle frames & body, Rivco is the brand you can depend on.