



**Parade Flag Holder or Quick Detach Rack
Mounting Kit For 2009 and Newer
Harley-Davidson
FLH, FLHX & FLT Models Part # HWK020**

Note: On 2009 thru 2013 models proceed as follows. On 2014 and newer models, see below after step 7 of 2009-2013 instructions.

Note: On 2014 and newer models equipped with optional H-D accessory saddlebag guard rails, the rails mounting bracket will need to be modified as shown in photo (6) and described in Step 3. For 2014 and newer models.

1. Remove the saddlebags.
2. Referring to photo (1), locate and remove the two original lower fender/saddlebag support mounting bolts (1A) and the two original upper fender support bolts (1B).
3. Referring to Diagram (2) - Compare the two receiver brackets to identify the left and right.

Refer to photo and Diagram (3) for installation on models **with** rear fender bumper and or saddle bag guard rails such as Classic and Ultra models.

Refer to photo and Diagram (4) for installation on models **without** rear fender bumper and or saddle bag guard rails such as Street Glide and Road Glide models.

4. Using the two shorter 5/16 x 1 ¼" bolts (supplied) with a flat washer on each bolt (supplied), install the left and right receiver brackets as per Diagram (3 or 4) depending on your model. **Note:** Position of the rear fender bumper, saddlebag bag guard rail, inner fender support bracket and saddlebag support brackets as well as the use of the two additional 5/16" washers (supplied) if required on your model. Install the supplied locking nuts but do not tighten.
5. Install the remaining longer 5/16" x 1 ½" bolts in the upper holes (photo 1B) as follows. Place a lock washer and flat washer (supplied) onto each bolt. Place the bolt thru the bracket, place the supplied spacers onto the bolts then thread the bolt into the hole but do not tighten bolt.
6. Using your Flag Holder or Quick Detach Rack assembly - which should also be assembled loosely (the bolts which secure the rods should not be tightened yet). Spread a thin coat of light grease over the last 3" of the rods and inside the receiver tubes. Insert the rods into the receiver tubes. Tighten the upper and lower receiver bracket mounting bolts (1A & 1B) securely (10-12 ft lbs.), then tighten the four bolts which secure the pins to the Flag Holder or Quick Detach rack securely. Check to see that the flag holder assembly slides in and out of the receiver brackets smoothly. If it does not, you may need to loosen the bolts, realign the brackets and rods then retighten. It may also help to grasp the Flag Holder or the Rack firmly and twist or flex it slightly to gain the proper alignment. This step may be necessary due to variances in manufacturing tolerances from

one motorcycle to another and that the fender/saddlebag supports brackets are not high precision parts.

7. Insert the locking pins supplied with the Flag Holder or Quick Detach Rack through the holes in the receiver brackets and rods, and lock the pins. Reinstall the saddlebags.

2014 and newer models:

1. Starting on the right side - remove the saddle bag support to fender support bracket bolt and nut (photo 5 A) located just behind or inward of the larger bolts that are visible (1B) - these larger bolts will NOT be removed. Remove the fender support bolt (5C).
2. Referring to Diagram (2) - compare the two receiver brackets to identify the left and right.
3. If equipped with optional H-D accessory saddlebag guard rails, the Rails Mounting Bracket must be modified as shown in photo (6) to gain clearance for both accessories to be used at once. This will move the guard rails outward about 3/8" and they will actually be more centered on the saddlebag (as viewed from the rear) than they are originally. Remove the guard rails. Lay the rail upside down on a towel or cloth to prevent scratches. Referring to photo (6) (notice the guard rail is shown upside down) mark the bracket as shown for the cut out and two new holes. Make the cuts using a hacksaw or abrasive cut-off wheel. Drill the new 3/8" and 13/32" holes as shown. Using a small brush and silver or clear spray-paint, spray a small amount of paint into the can's cap and touch up or paint the bare steel edges and holes. Reinstall the guard rails, place the larger 3/8" bolt thru the new 13/32' hole. Install the nut on the bolt and the front clamp for the guard rail loosely. Install the flag/rack brackets (HWK020) as described below, and then tighten the guard rail mounting bolts and clamps.
4. Install the right bracket as shown in photo (3&4) with the lower tab of the bracket being **behind or to the rear of the fender and saddlebag support brackets**. At the bottom, use one of the supplied 5/16" x 1 1/4" bolts with a washer on it. Place the bolt thru all of the brackets and one of the supplied lock nuts on the front. At the top use one of the supplied 5/16" x 2" bolts with a lock washer and washer on it. Place the bolt thru the bracket, then one of the supplied spacers onto the bolt then thread the bolt into the hole. Do not tighten yet. Install the left bracket in the same manner as the right.
5. Using your Flag Holder or Quick Detach Rack assembly - which should also be assembled loosely (the bolts which secure the rods should not be tightened yet). Spread a thin coat of light grease over the last 3" of the rods and inside the receiver tubes. Insert the rods into the receiver tubes. Tighten the upper and lower receiver bracket mounting bolts (1A & 1C) securely (10-12 ft lbs.), then tighten the four bolts which secure the pins to the Flag Holder or Quick Detach Rack securely. Check to see that the Flag Holder Assembly slides in and out of the receiver brackets smoothly. If it does not, you may need to loosen the bolts, realign the brackets and rods, and then retighten. It may also help to grasp the Flag Holder or the Rack firmly and twist or flex it slightly to gain the proper alignment. This step may be necessary due to variances in manufacturing

tolerances from one motorcycle to another and that the fender/saddlebag supports brackets are not high precision parts.

6. Insert the locking pins supplied with the Flag Holder or Quick Detach Rack through the holes in the receiver brackets and rods, and lock the pins. Reinstall the saddlebags.

IMPORTANT: When using the Quick Detach Rack, do not exceed the 35 lb. weight limit of the rack and be sure all tail lights and turn signals are visible when the rack is loaded. We offer an additional tail/brake and turn light set that mounts to the back of the rack (RIVCO pt# CRLGHT) for added safety and when the tail lights may be obstructed by cargo on the rack. When using RIVCO's Parade Flag Holder accessory with these brackets, refer to the 25 M.P.H. maximum speed recommended when riding with a flag displayed.

Photo#1

Equiped with rear fender bumper and saddle bag guard rails

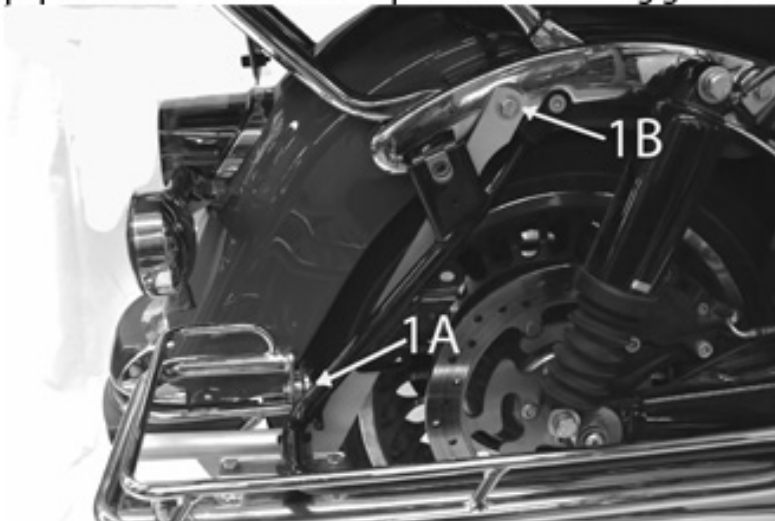

Not equiped with rear fender bumper and saddle bag guard rails



Diagram 2

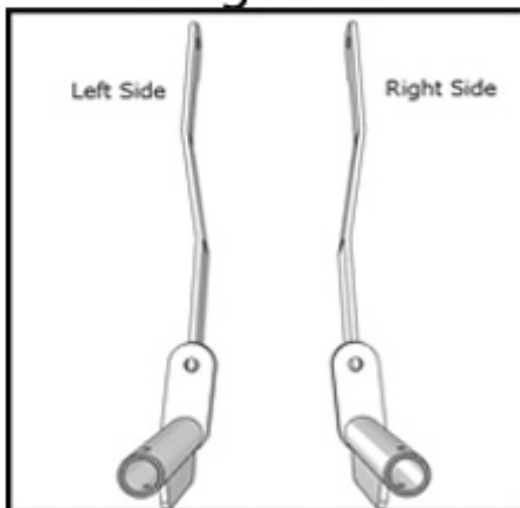

Models equipped with rear fender bumper and or saddle bag guard rails

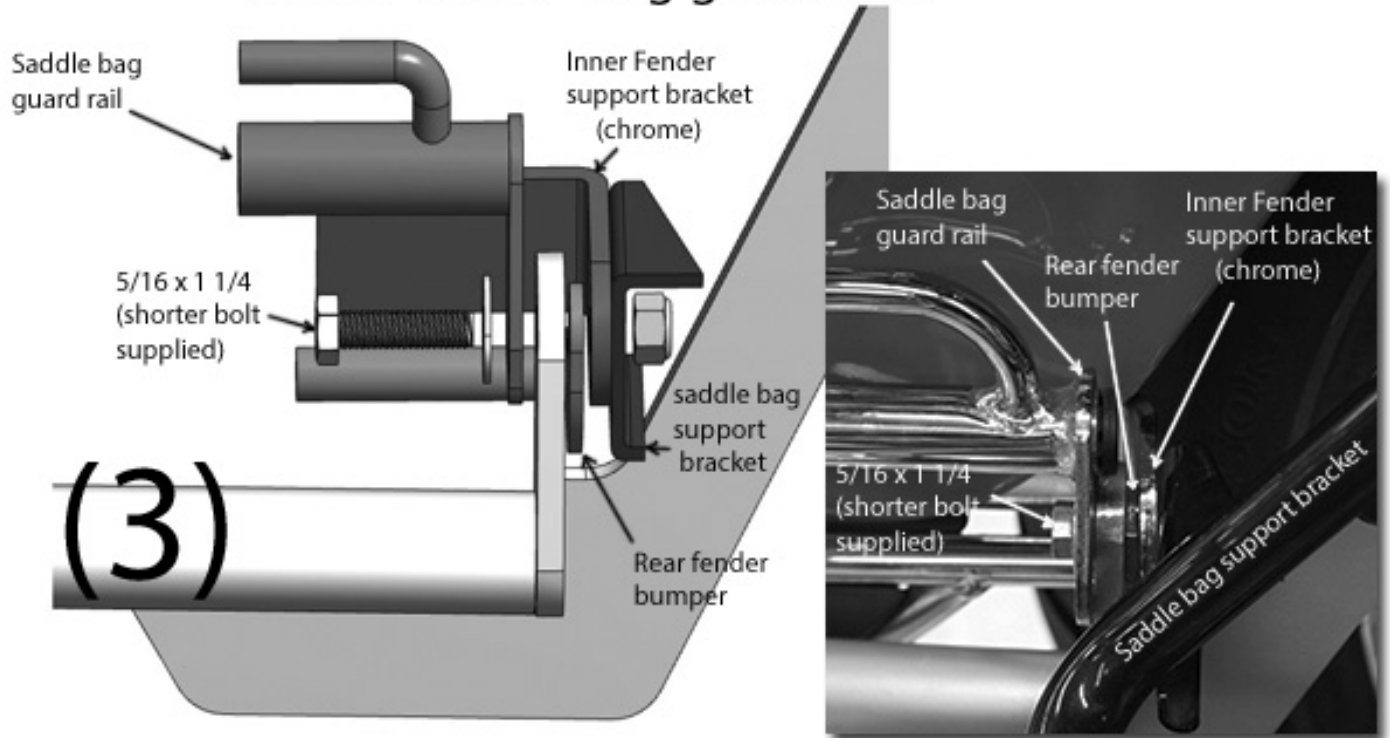

Models not equipped with rear fender bumper and or saddle bag guard rails

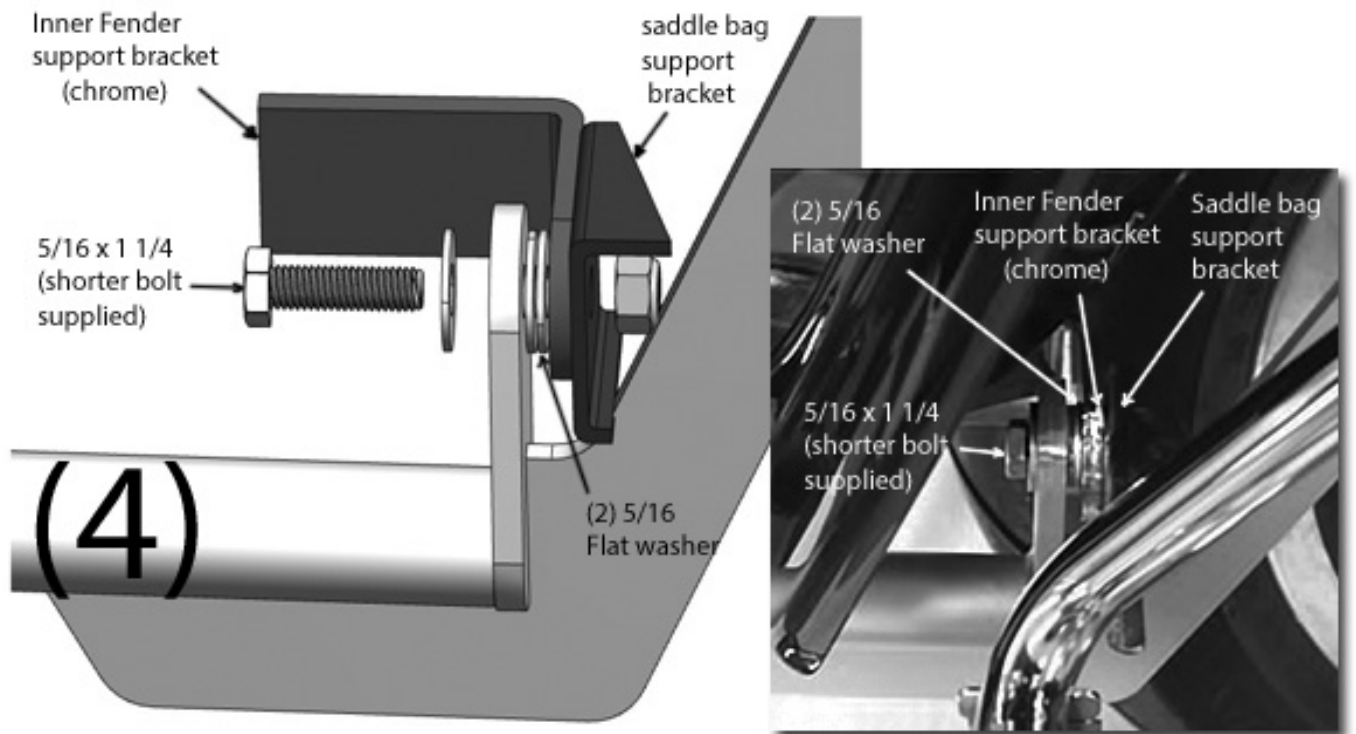

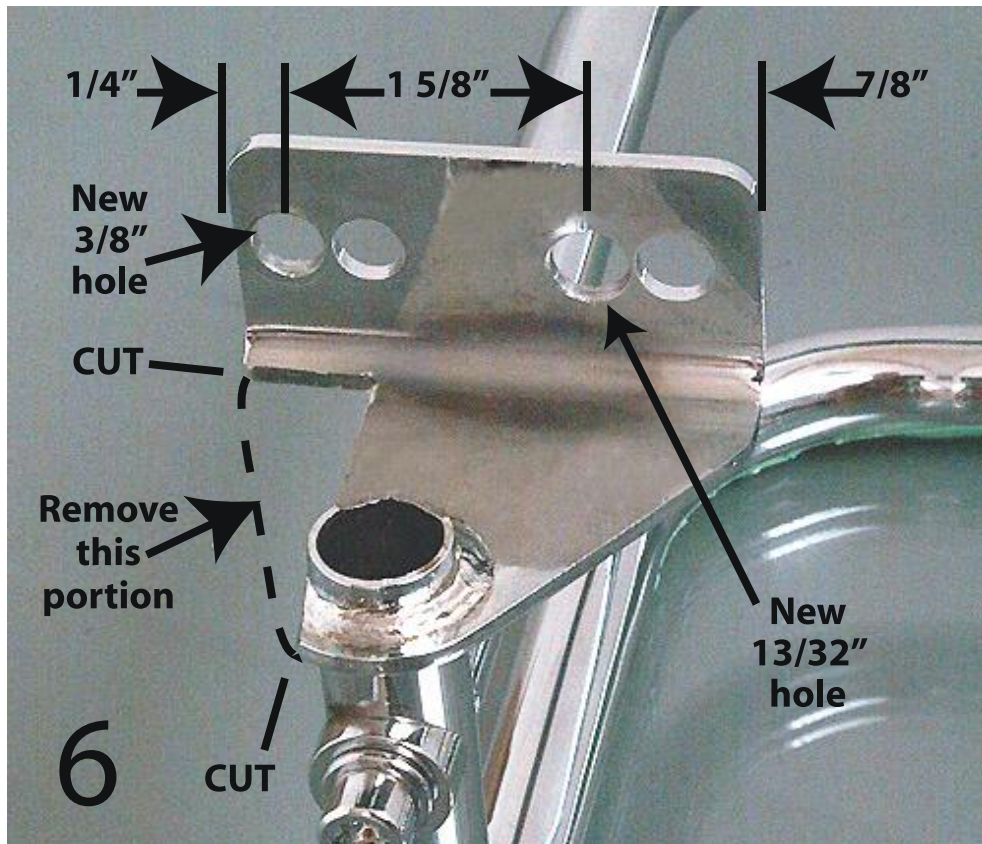
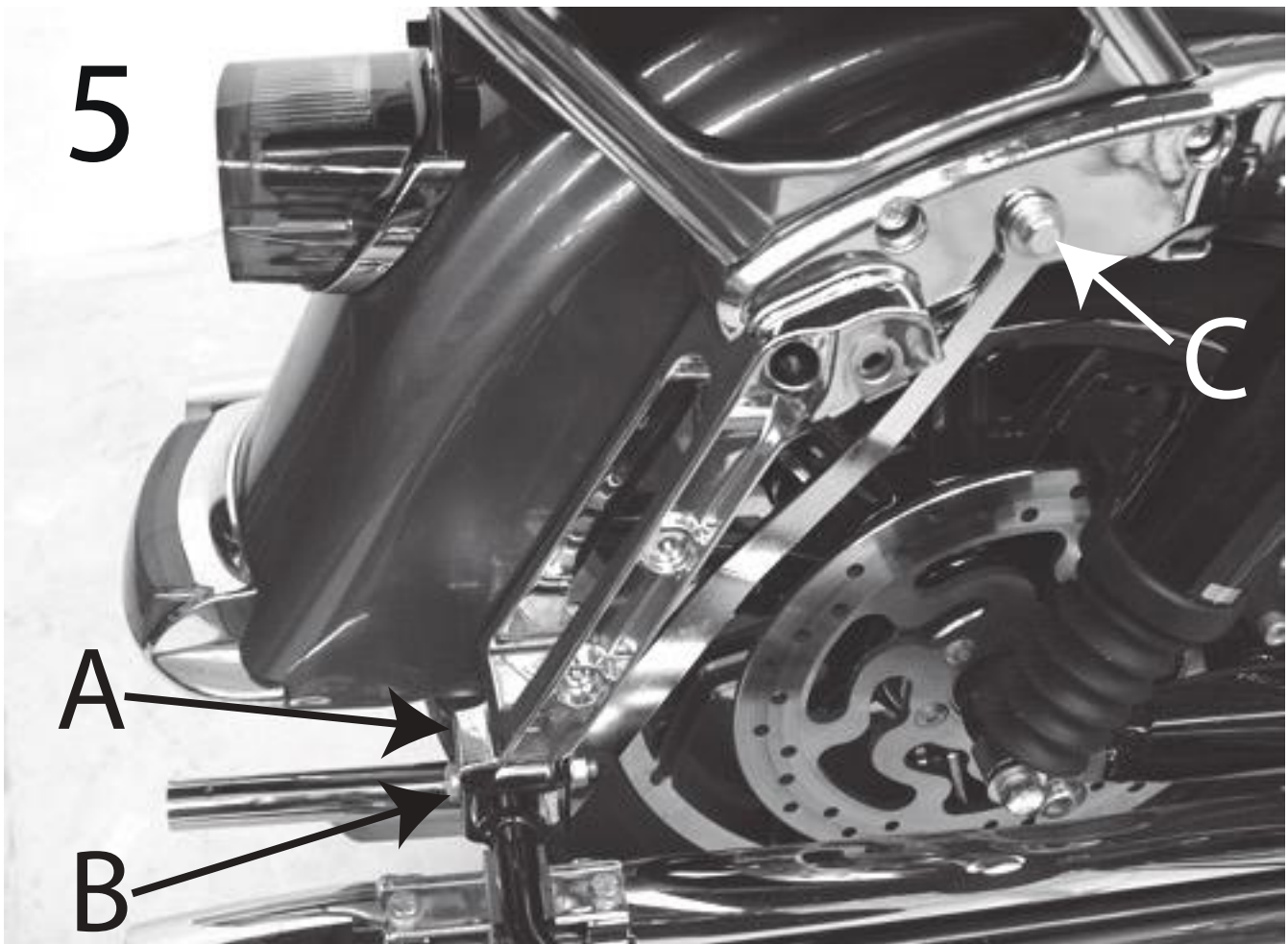

Rely only on high-grade motorcycle luggage systems & saddlebags offered on our virtual shelves.