

Installation Instructions

Highway Mounts for 1 ¼" Engine Guards

#HD005

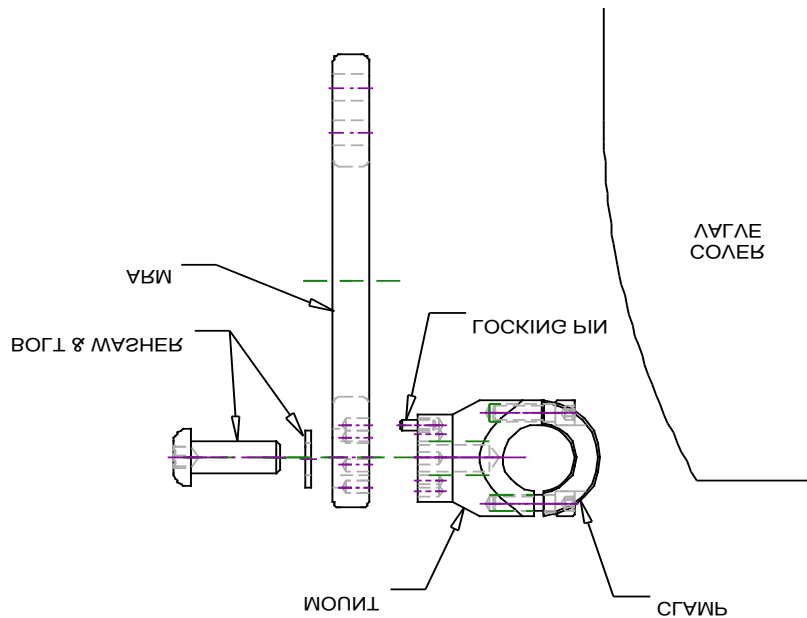

Notice that if you hold the mount and clamp together there is a gap only on one side. This gap should be towards the rear of the engine guards or facing you as you sit on the bike.

Loosely assemble the mount and clamp onto the engine guard tube. Without lowers the arm may be mounted on the inside or outside of the crash bar, with lowers it must be mounted on the outside only. Next assemble the bolt, washer, arm & locking pin as shown. *Note: You may want the arms to lean outward slightly to give more room for your legs around the fairing lowers.* Tighten the front screws securely.(side without the gap) Then the rear.

Adjusting the arm angle. Notice that there are 8 locking pin holes in the mount and 7 in the arm. By leaving the pin in the mount and rotating the arm to its next hole, it will move the arm 50 deg. When you get close to the desired angle you may make adjustments in 5 deg. increments by moving the pin to the next hole in both the mount and the arm. Moving to the next set of holes clockwise will move the arm counter clockwise 5 deg. Moving the pin to the next set of holes counter clockwise will move the arm clockwise 5 deg. This will provide 72 different mounting angles total. Install the large bolt and washer, tighten securely and install your pegs or highway boards . *Note: When installing boards, put the lock or star washer between the board and the arm to prevent them from rotating under heavy pressure.*

