



FP0172

FITTING INSTRUCTIONS FOR FP0172BK FORK PROTECTORS
HONDA VFR800X CROSSRUNNER '15-

Page | 1



THIS KIT CONTAINS THE ITEMS PICTURED AND LABELLED BELOW.
DO NOT PROCEED UNTIL YOU ARE SURE ALL PARTS ARE PRESENT.

Please note that the way the kit is packed does not necessarily represent the way of mounting to the bike

Please note that in cases where kits are packed with a plastic tube separating components on the spindle bar (this tube should be discarded).

THE PARTS SHOWN MAY BE REPRESENTATIVE ONLY (FOR CLARITY OF INSTRUCTIONS ONLY)

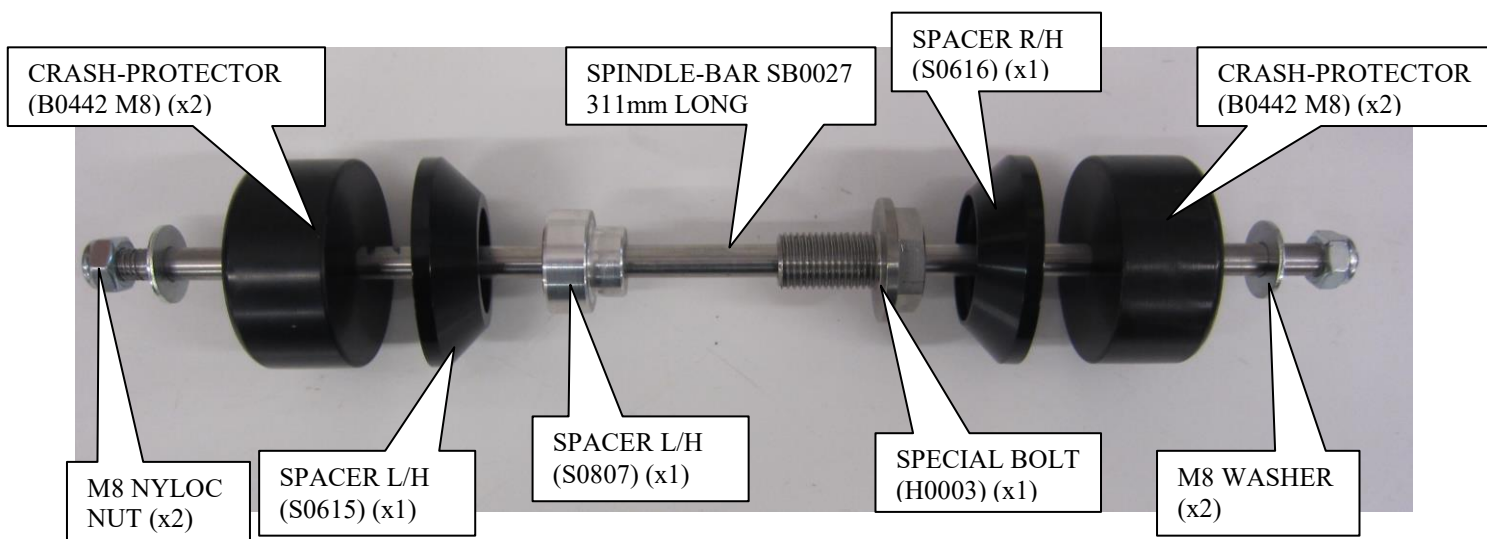

TOOLS REQUIRED

- Socket set to include 2x 13mm & 22mm sockets and wrenches.



FP0172

Page | 2



PICTURE A

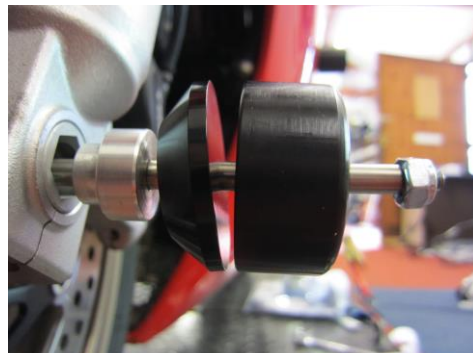

PICTURE B

FITTING INSTRUCTIONS

Right-hand side (as you sit on bike)

- Remove spindle nut and replace with new one supplied in kit (H0003).
- Place the ring type spacer (S0616) over the hexagon of the replacement spindle nut just fitted (only one will fit over the hexagon).
- Fit one nut and washer on spindle-bar (SB0027) (the end with shortest thread).
- Feed spindle-bar with nut and washer through the crash protector (B0442 M8) and into the front wheel spindle from the right hand side (through the spindle nut just fitted) so nut goes into recess as shown in picture A.
- Place the stepped location spacer (S0807) over the exposed thread on the left hand side so it locates into the spindle on the left hand side as shown in picture B.
- Place remaining ring type spacer (S0616) over exposed end of spindle-bar so it fits over the location spacer just fitted as shown in picture B.
- Place remaining crash protector over exposed end of spindle-bar as shown in picture B.
- Fit washer and nut from kit onto thread and tighten until both nuts are engaged in nylon and equal amounts protrude from either side. Do not overtighten – the nyloc nuts will hold it tight.

CONSUMER NOTICE

The catalogue description and any exhibition of samples are only broad indications of the Products and R&G may make design changes which do not diminish their performance or visual appeal and supplying them in such state shall conform to the order. The Buyer acknowledges no representation or warranty (other than as to title) has been given or will apply to the Products other than those in R&G's order or confirmation and the Buyer confirms it has chosen the Products as being of merchantable quality and suitable for its particular purposes. Where R&G fits the Products or undertakes other services it shall exercise reasonable skill and care and rectify any fault free of charge unless the workmanship has been disturbed. The Buyer is responsible for ensuring that the warranty on the motorcycle is not affected by the fitting of the Products. On return of any defective Products R&G shall at its option either supply a replacement or refund the purchase money but shall not be liable if the Products have been modified or used or maintained otherwise than in accordance with R&G's or manufacturer's instructions and good engineering practice or if the defect arises from accident or neglect. Other than identified above and subject to R&G not limiting its liability for causing death and personal injury, it shall not be liable for indirect or consequential loss and otherwise its liability shall be limited to the amounts paid by the Buyer for the Products or the fitting or service concerned. These terms do not affect the Buyer's statutory rights.