

Parts Index

* not to scale

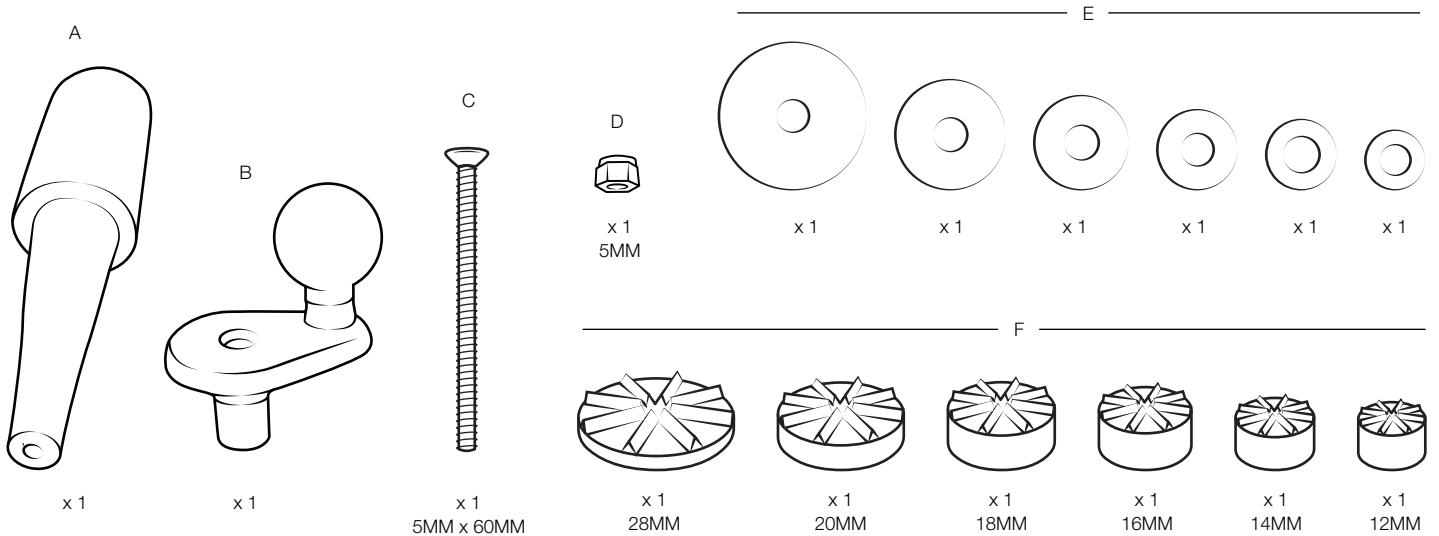

1 Measure inside diameter of fork stem to determine which side of the (A) expansion plug your install requires.

- 12-26mm fork stem holes
- 27-38mm fork stem holes

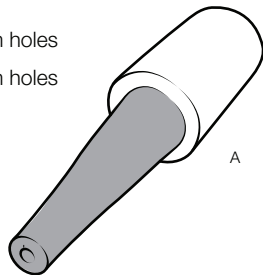

2 Gently insert the side of the (A) expansion plug that was determined in Step 1 into the stem hole and mark approximately 1/8" above the opening. Remove plug and cut marked line. Measure 1" below the top cut and cut along that line as well.

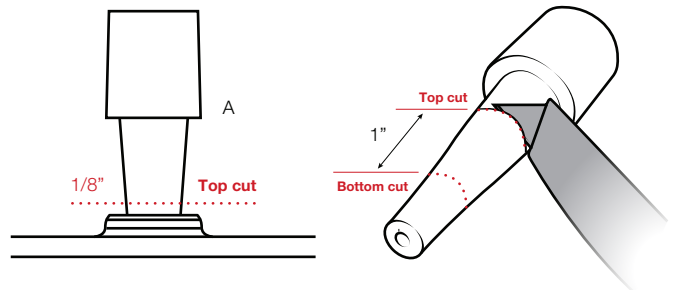

3 Assemble components as shown before using appropriate (E) Washer and (F) Nut Pocket Washer. Diameter of selected (E) Washer must not be wider than diameter of the top cut of (A) Expansion Plug. Tighten assembly until (F) Nut Pocket Washer has a firm grip on (A) Expansion Plug.

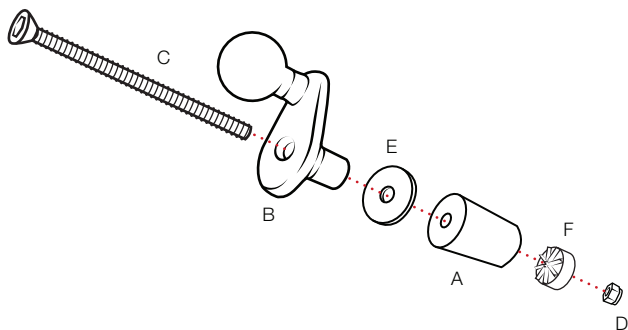

4 Insert assembly into fork stem hole until ball plate is flush with your bike. Tighten (C) Screw using a 3mm allen wrench. Periodically check the friction of the assembly to ensure it is tightening properly. If your assembly is not tightening, the (F) Nut Pocket Washer may not be gripping on the expansion plug. Remove assembly from hole and pre-tighten further, then repeat.

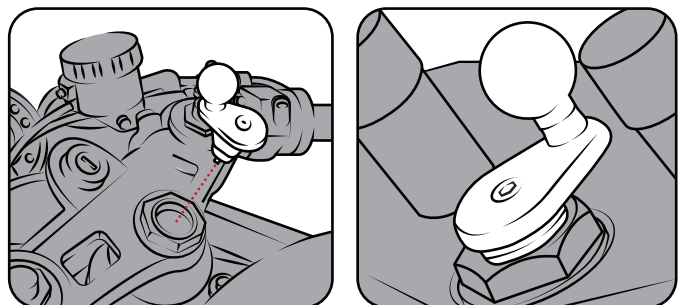

Parts index

* not to scale

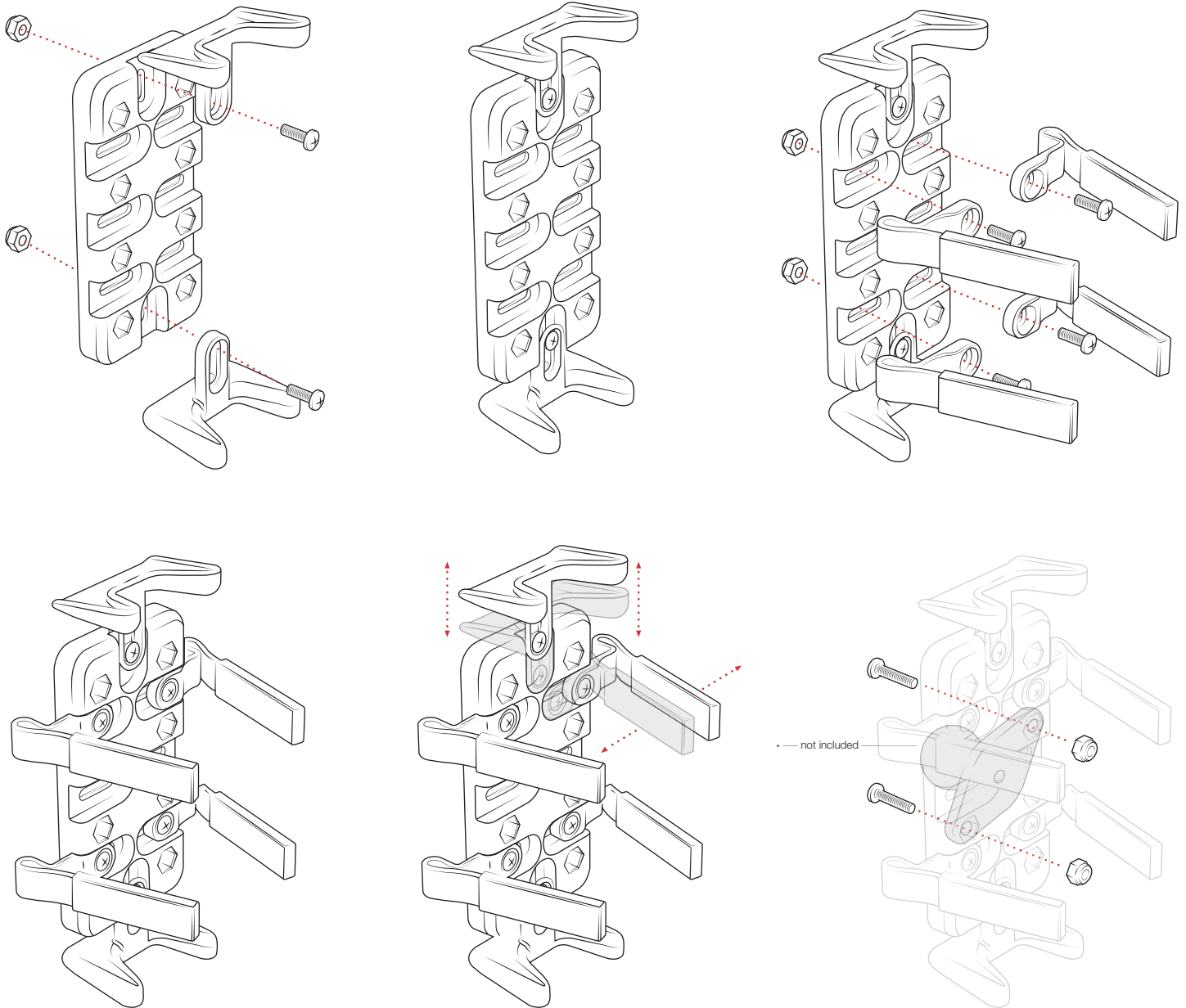
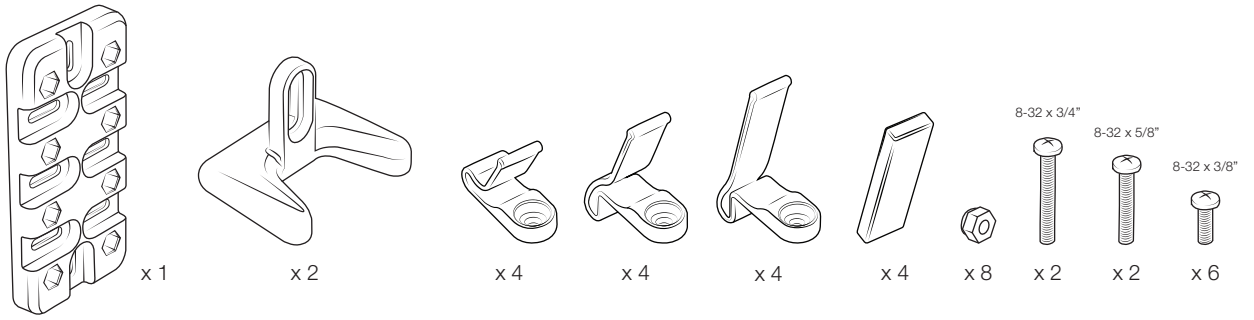

RPR-INS-UN4