

Shock Gold Valve Installation

SPECIAL INSTRUCTIONS - SMGV 5043

NOTE: Husqvarna Sachs Shocks—These shocks have a ball bearing check-valve in the center of the shock shaft that creates excessive damping (harshness). The first hex (10mm) on the end of the shaft is the retaining bolt/jet. Remove this retaining bolt along with the check ball and spring.

SHOCK REBUILD - BLADDER RESERVOIR

(Links to Gold Valve Installation)

(Links to Piston Reservoir Assembly)

Reservoir shocks are common on motorcycles and ATVs, both dirt and street. They have either integral reservoirs built into the body or external remote reservoirs attached with a hose.

These shocks use either a bladder or a floating piston to separate the oil and nitrogen in the reservoir. Most of the procedure is the same. Assembly-only is covered in the [Piston Style Reservoir Shock Rebuild](#).

CAUTION: IF YOU ARE UNFAMILIAR WITH REBUILDING AND REVALVING SHOCKS, STOP!!! DO NOT PROCEED; SEEK OUT A QUALIFIED SUSPENSION TECHNICIAN.

Shortcuts:

- > [SHOCK DISASSEMBLY](#)
- > [VALVING AND SHAFT ASSEMBLY](#)
- > [SHOCK ASSEMBLY](#)



TSNN 01 Nitrogen Needle

Tools

- Torque wrench (SnapOn Digital Torque Wrench shown)
- Metric calipers and micrometer
- [TMPS 01 or 02 Pin Spanner](#) for [Screwed-on Body Caps](#)
- [TMVJ 065 Vise Jaws](#) mounted on a Vise - suggested
- [TSSB Series Bullet Tool](#) - for Seal Head installation
- [TSPA 01](#) - Shock Preload Adjusting Tool
- [TSSC 01](#) - Spring Compressor Lever Type or
- [TSSC 02](#) - Spring Compressor Screw Type
- Sharp Wood Chisel
- [TSCT 01](#) - Reservoir Cap Tool (optional see D12-D13)
- [TSCP 01](#) - Clip Tool
- [TSSH Series](#) - Seal Head Setting Tool

Nitrogen Charging Equipment

- [TSNG 02](#) - Shock Nitrogen Gauge
- [TSNN 01](#) - Nitrogen Needle
- [TSNR 01](#) - Regulator
- [TSNH 048](#) - High-pressure Nitrogen Hose

Supplies

- Contact Cleaner - or other good, clean solvent
- Loctite - Hi-Strength (included in the Gold Valve Kit)
- [USSG 01](#) - Ultra Slick Seal Grease
- [US1](#) - Ultra Slick Shock Fluid - extremely stable

SHOCK DISASSEMBLY

D1 - Place the end of the shock body in a vise, using Aluminum Vice Jaws (TMVJ 065), or secure using the shock eyelet with soft jaws. Be careful not to crush the shock body. Check clicker positions on dampers and note the settings. Back the adjusters out all the way.

D2 - Remove the spring by loosening the preload locking collar with a Shock Preload Adjusting Tool (TSPA 01).

A quicker way to remove the spring is to use TSSC 01 or TSSC 02 Spring Compressors. On some models a TSSC 02 is required to remove the spring.

***RESHOOT THIS PHOTO clamped lower and with a rag

D3 - Take the preload off of the spring by unscrewing the preload collar.

***Need pics using spring compressors - both types

D4 - Slide the bumper down and out of the bumper cup. Use a screwdriver to pry it down if necessary. Be careful not to damage the bumper.

Inspect the bumper. these are wear items and should be replaced regularly. Look for signs of deterioration including tearing on the OD.

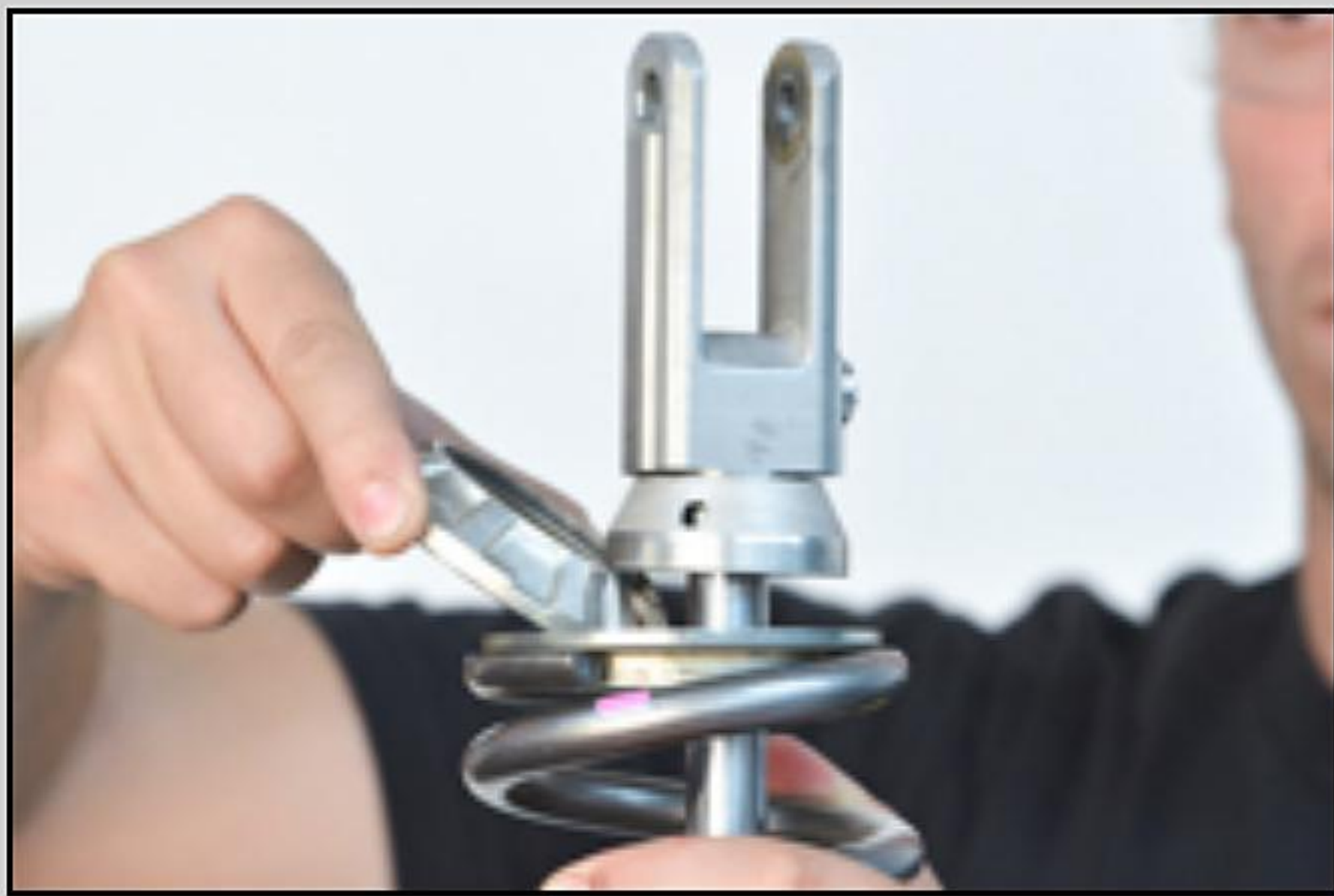

D5 - Remove the spring collar.

This is a KYB. The Spring Retainers on Showa shocks are commonly held on with a round wire clip that must be popped out of its groove.



D6 - Remove the spring.



D7 - Compress the shock and make sure it returns completely. If it does not, there may be a bent shaft, blown shaft seal, a bad bladder, low-pressure, or an improperly located piston (on reservoir piston shocks.)

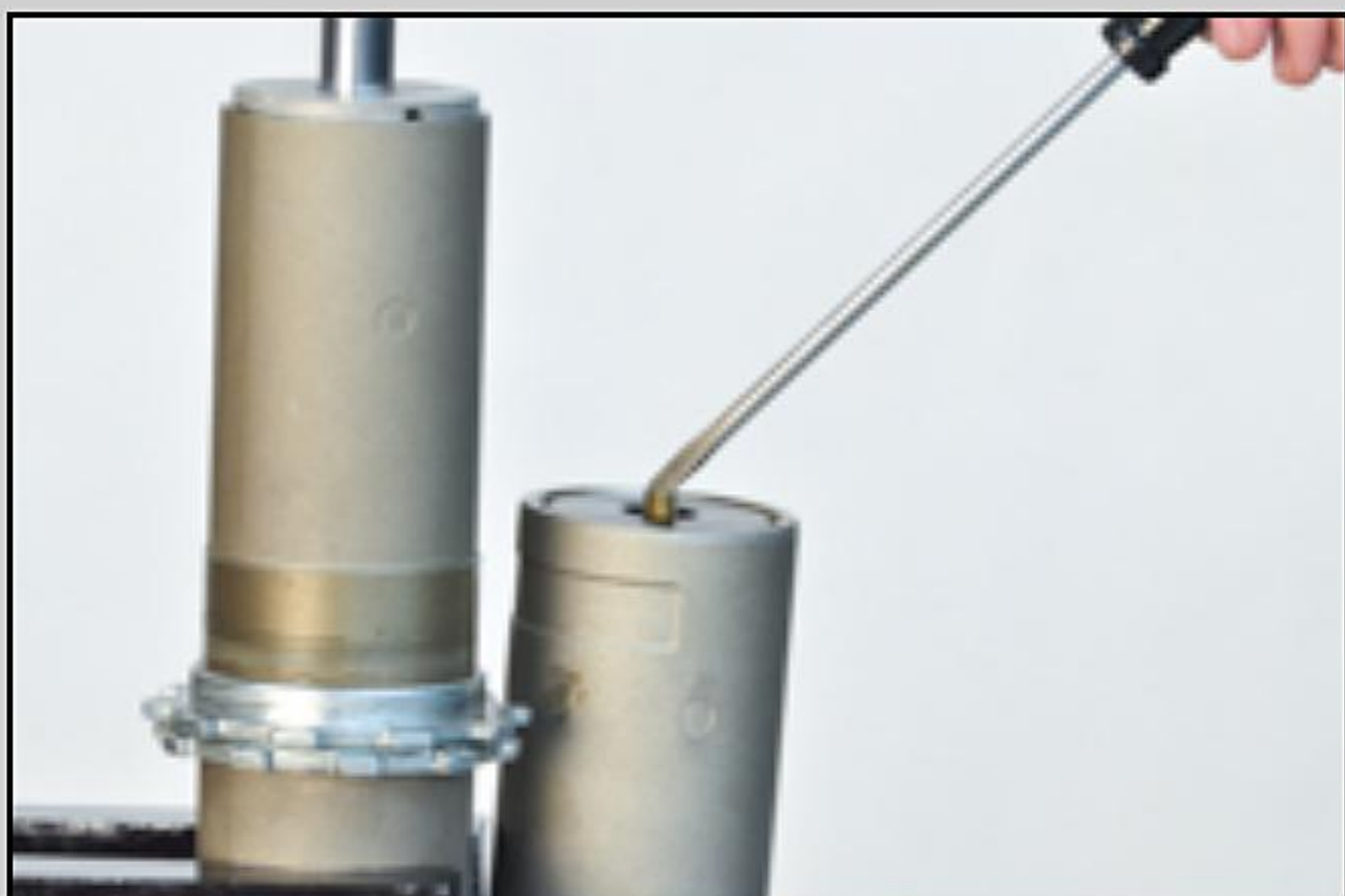

D8 - Remove the pressure from the reservoir by depressing the valve core. Some types use a nitrogen needle that pushes through a block of rubber instead of a Schrader valve.



D9 - Remove the valve with a valve core tool.



D10 - Depress the reservoir cap using a hammer and a socket to protect the valve stem.

On some models (common on WP) the cap is threaded instead of held in with a clip. Unscrew this type.



D11 - Remove the reservoir clip with a clip tool (TSCP 01).



D12 - Remove the reservoir cap. Method 1.

One method is to use a Reservoir Cap Removal Tool (TSCT 01). If you choose this method make sure the tool is screwed on **all the way**. Pull upwards with only the slightest side to side movement. This is so you don't break off the valve stem.

This is even easier if you depress the shock shaft at the same time.

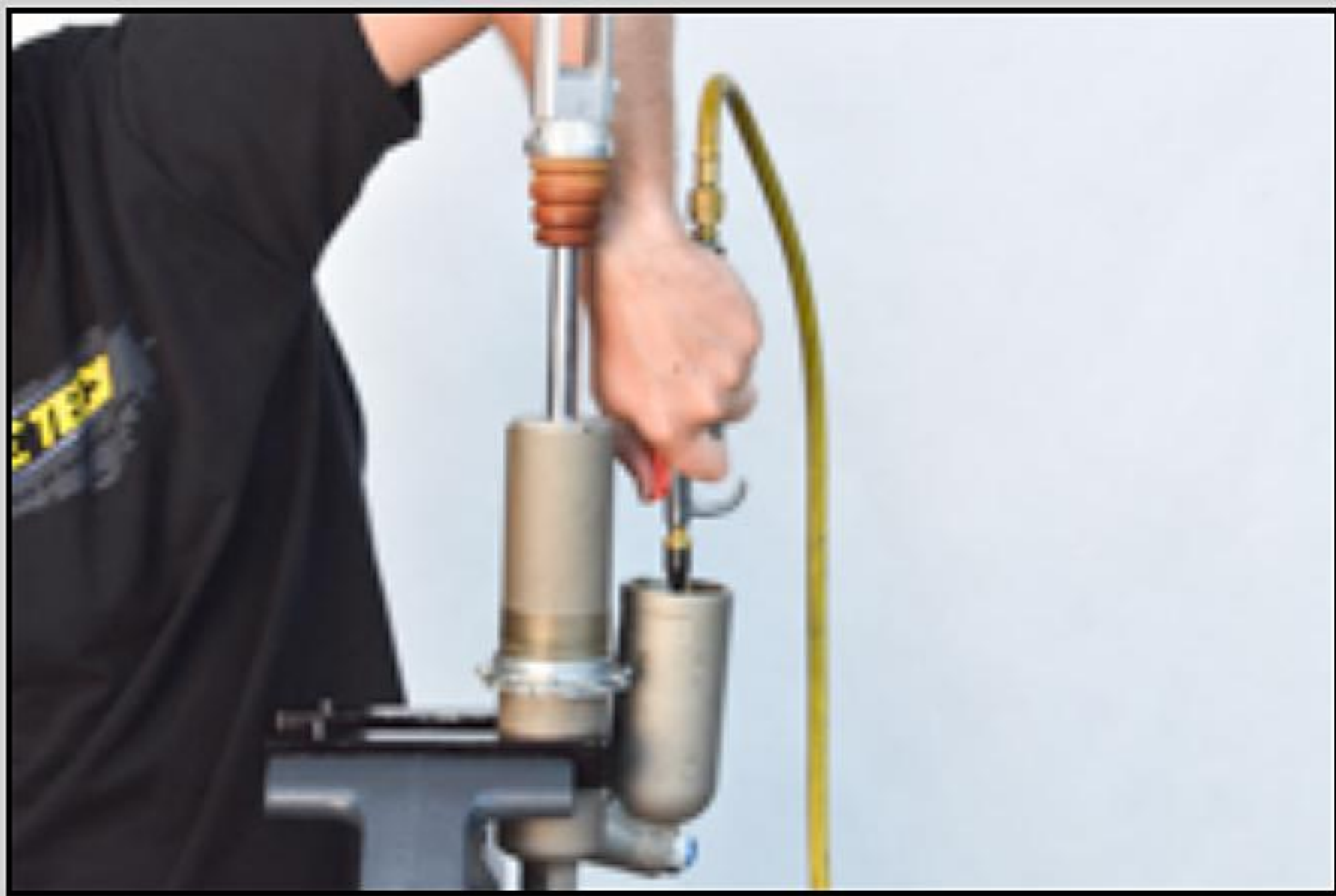

D13 - Remove the reservoir cap. Method 2.

My favorite method is to use a rubber tipped air gun and use compressed air to blow the cap off. The bladder cap will pop off with a bang.

This seems dangerous but as soon as the bladder pops off all the trapped air is released quickly and the cap doesn't go anywhere. I like to use my free hand and hold a rag over the end of the bladder cap to contain it and the oil.



D14 - Remove the shock body cap with a **sharp** wood chisel at the junction of the cap and the body.

On some models the cap screws on. Make sure which type it is before hitting it with a chisel. Most of these can be removed with a Pin Spanner (TMPS Series).

Screw-on caps include:

- Elka
- KYB 1981-85 dirt (remove the set screw if present)
- Ohlins - early thru about 1995
- Penske
- Works Performance
- WP - early thru about 1995
- WP 36mm - some



D15 - Compress the seal head into the body with a Seal Head Setting Tool (TSSS Series) to expose the circlip.

On some models, notably early Yamaha, the seal head is sandwiched between two circlips. This makes clip removal much more difficult, but that's another story.

SHOCK ASSEMBLY - Bladder Reservoirs

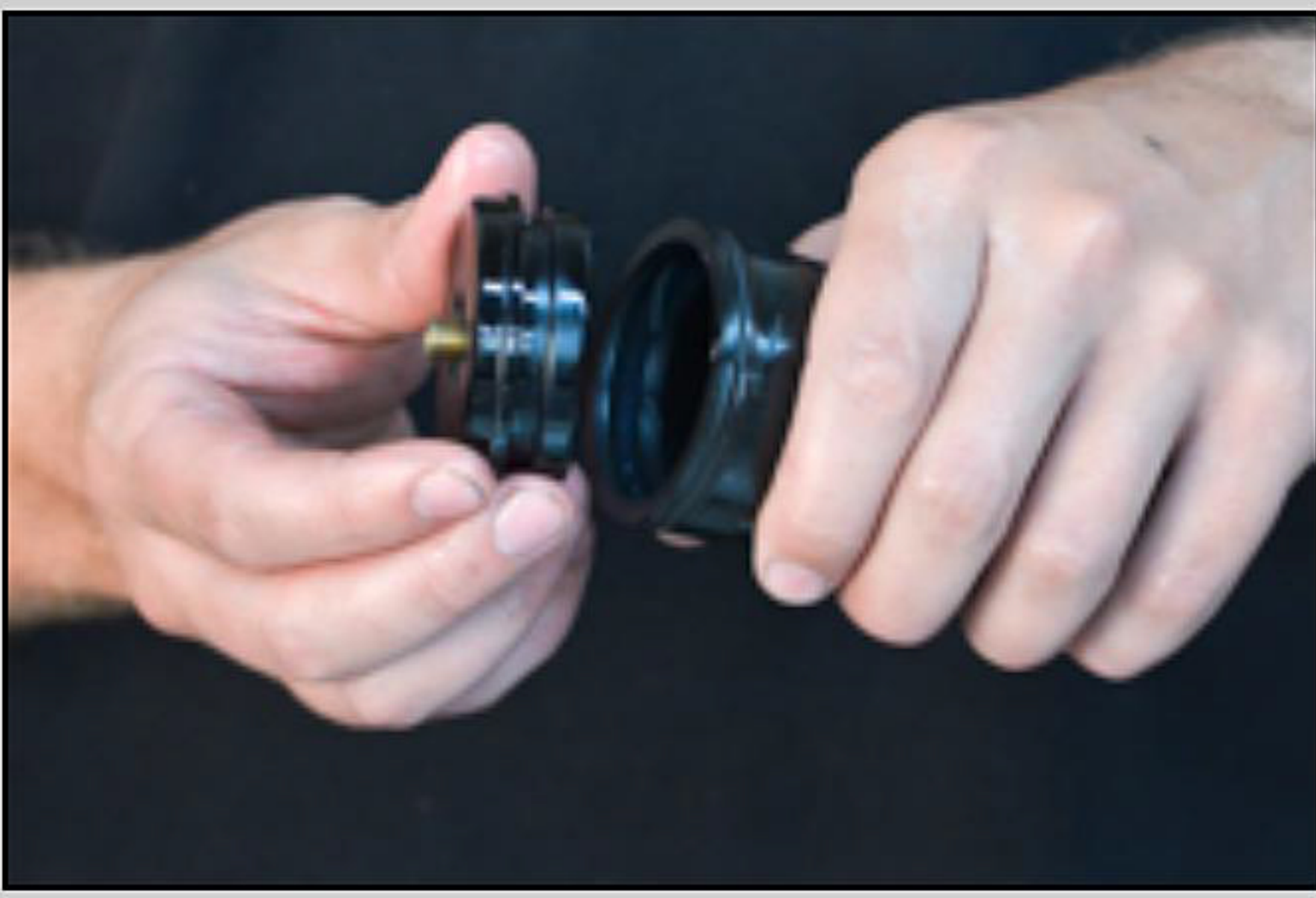

A1 - For bladder shocks reinstall the valve core and bladder onto the reservoir cap.

This shows a manual bleed.



A2 - Pour Ultra Slick Suspension Fluid into the reservoir.



A3 - Make sure there is enough oil so that when the bladder goes into the reservoir, it overflows slightly. This insures there are no air bubbles trapped under the bladder.



A4 - Push down on the bladder cap until the circlip groove is exposed.



A5 - Reinstall the reservoir clip completely into the groove.

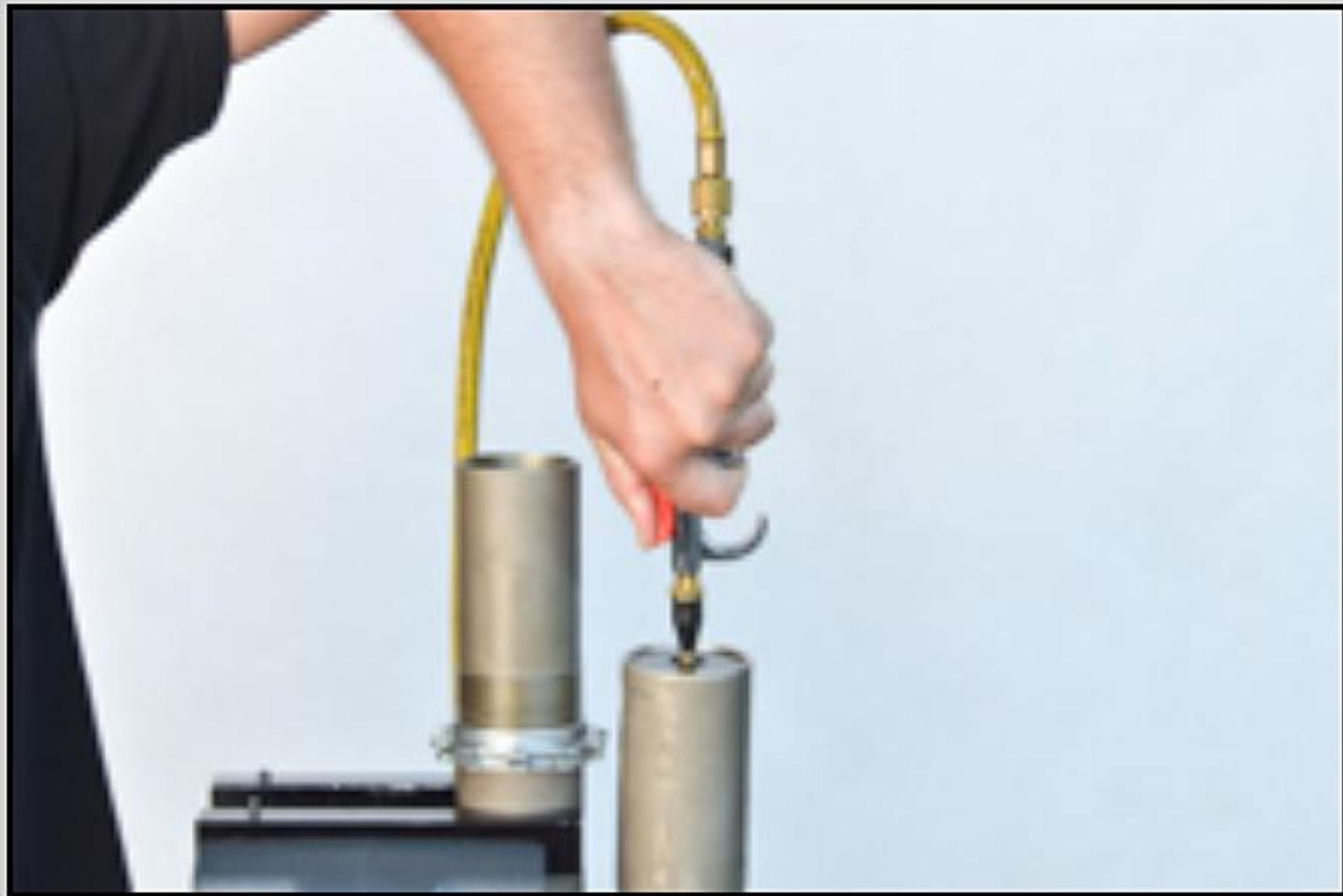

A6 - Pressurize the bladder using compressed air to about 25 to 60 psi. The exact pressure is not critical. A rubber tipped air gun is easiest. This will seat the bladder cap and overexpand the bladder.



A7 - Fill the shock body with oil up to about 50mm (2") from the top.



A8 - Install the shaft assembly into the shock body. Make sure the piston band stays in the groove and is not pinched.



A9 - Top off the fluid to within 10mm of the top of the shock body.



A10 - To bleed the shock, **push down firmly and pull up slowly** until no more bubbles show up on the compression stroke.

If you pull up too quickly, the fluid will cavitate and you will not remove the bubbles. If you pull up too far the rebound feed holes will be exposed and it will suck in air.

Either AJ is really angry or his puny "wanna be a fireman" muscles have been grossly overtaxed.



A11 - For shocks with a lot of compression damping use a plastic mallet and firmly tap on the end of the shaft to open the valving stack. This forces the valving to open and allows any trapped air to go past the piston.



A12 - Once it is bled, extend the shock and top it off with fluid.

Do not allow the low-speed rebound inlet hole to be exposed as it will suck in air and you will need to start the bleeding process again.



A13 - Push in the seal head using a Seal Head Setting Tool (TSSS Series) until the O-ring seals. Maintain pressure on the top of the seal head.



A14 - Once the O-ring seals on the body you will not be able to insert the seal head in any further. This is because you are pushing against the reservoir pressure.

Depressurize the reservoir bladder while keeping downward force on the seal head. This will allow the seal head to go into the shock body.



A15 - Continue to push down on the seal head until the circlip groove is exposed.

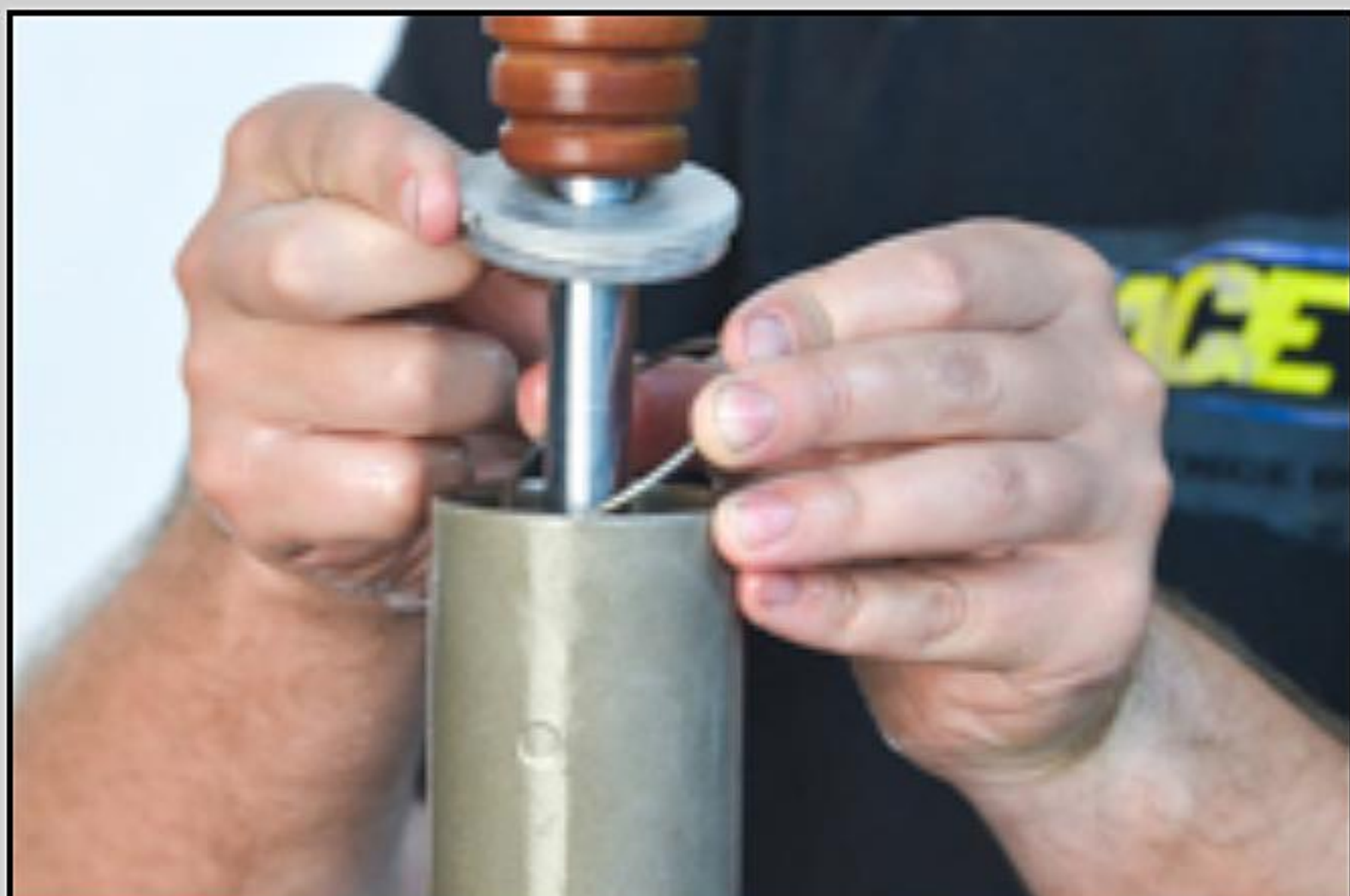

A16 - Install the circlip into the groove. Make sure it is completely seated in the groove.

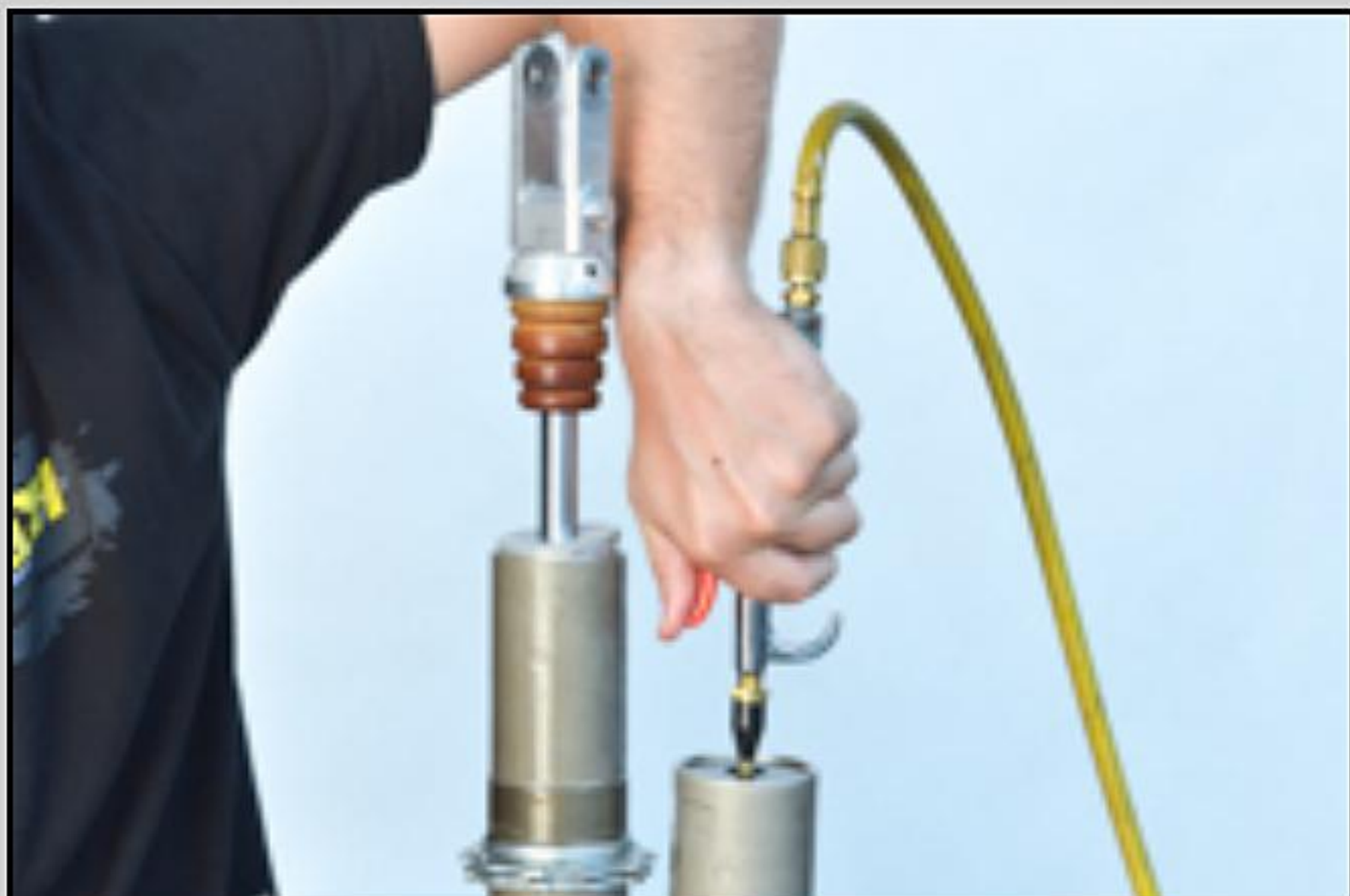

A17 - Gently pressurize the reservoir and make sure the seal head and circlip are properly seated.

The shaft should extend all the way. If it does not check to see what is wrong (not enough oil, bent shaft, etc.)



A18 - For pressed-in body caps tap it evenly into the shock body.

Align the vent holes in the body cap with the eyelet. When you ride in wet conditions this allows water that has worked its way past the cap to drain out when mounted on the bike.

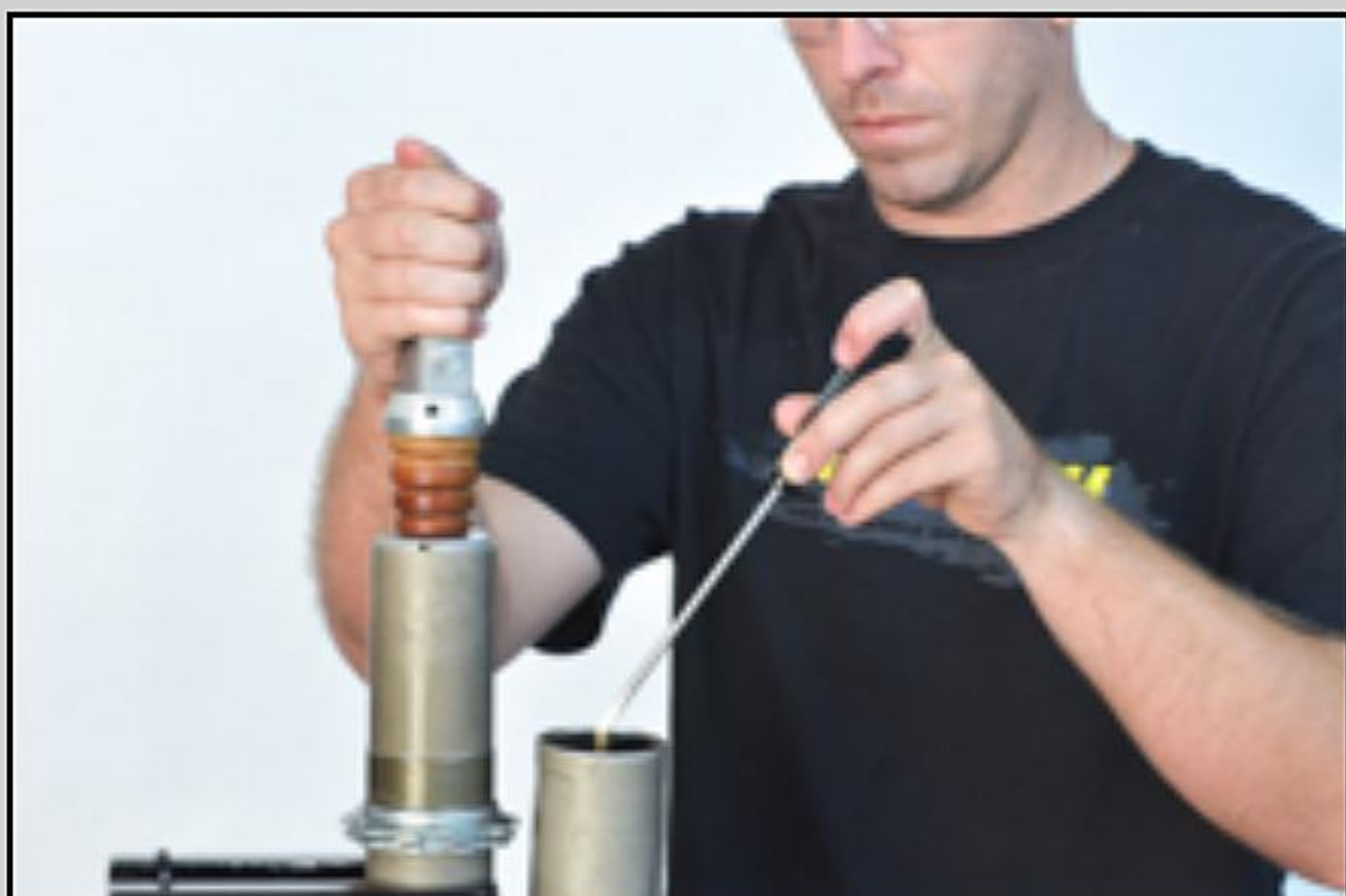

A19 - Compress the shock while depressurizing the bladder.

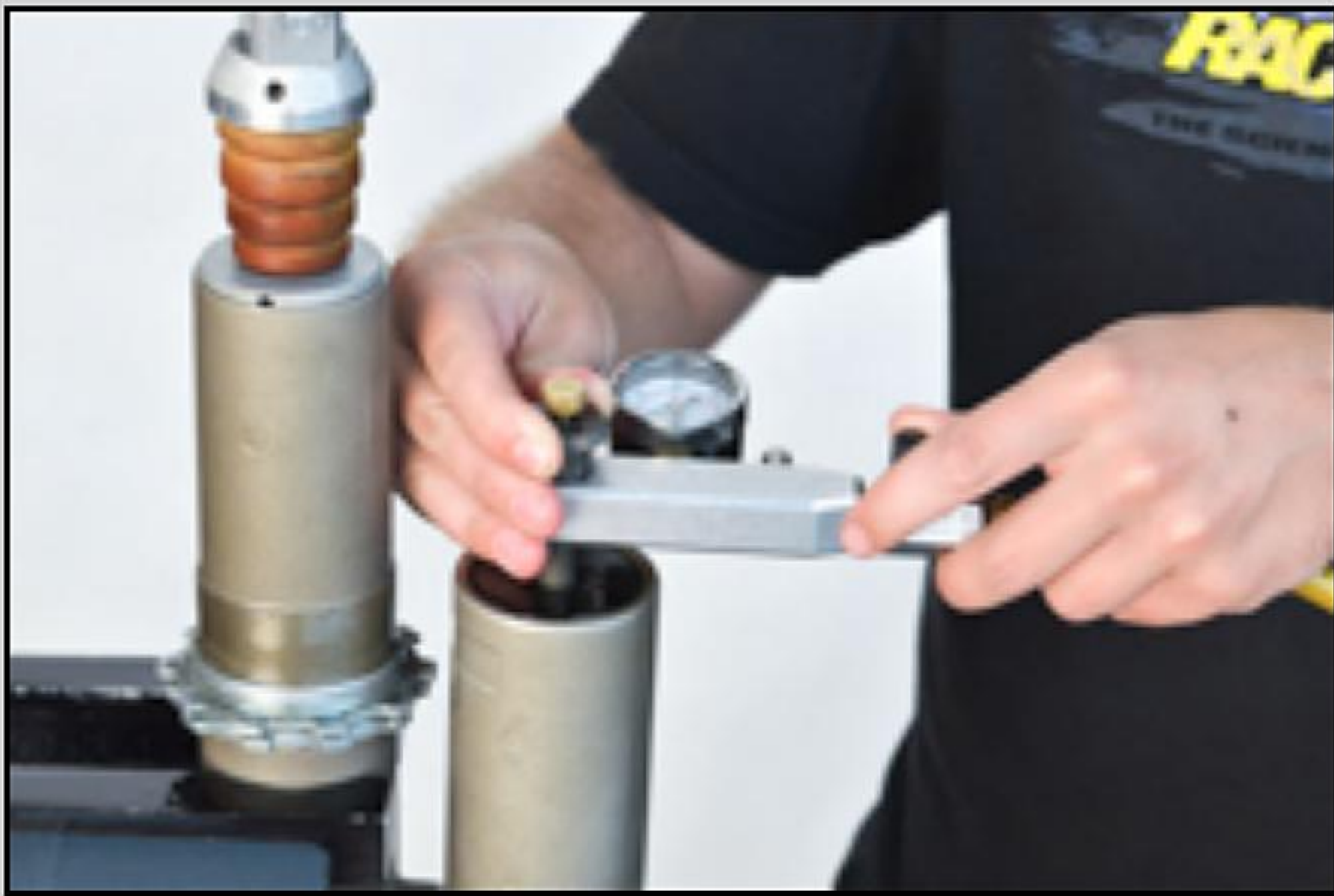

A20 - Pressurize the reservoir with nitrogen using the Shock Nitrogen Gauge (TSNG 02).

Available from Race Tech:

- Regulator (TSNR 01)
- High-pressure Nitrogen Hose (TSNH 048)
- Nitrogen Gauge (TSNG 02)

Nitrogen tanks are available in many sizes at welding supply stores.



A21 - Set the shock to the proper pressure according to the DVS Setup Sheet.



A22 - Stroke the shock shaft. The shaft should extend all the way. If it doesn't, the shock is probably underfilled (if it is a piston style reservoir the piston may be at the end of the body) or the shaft is bent. Check the body and shaft as well. Stroke the shock to feel for proper function and smoothness.

Grease the preload collar thread before installing the spring.

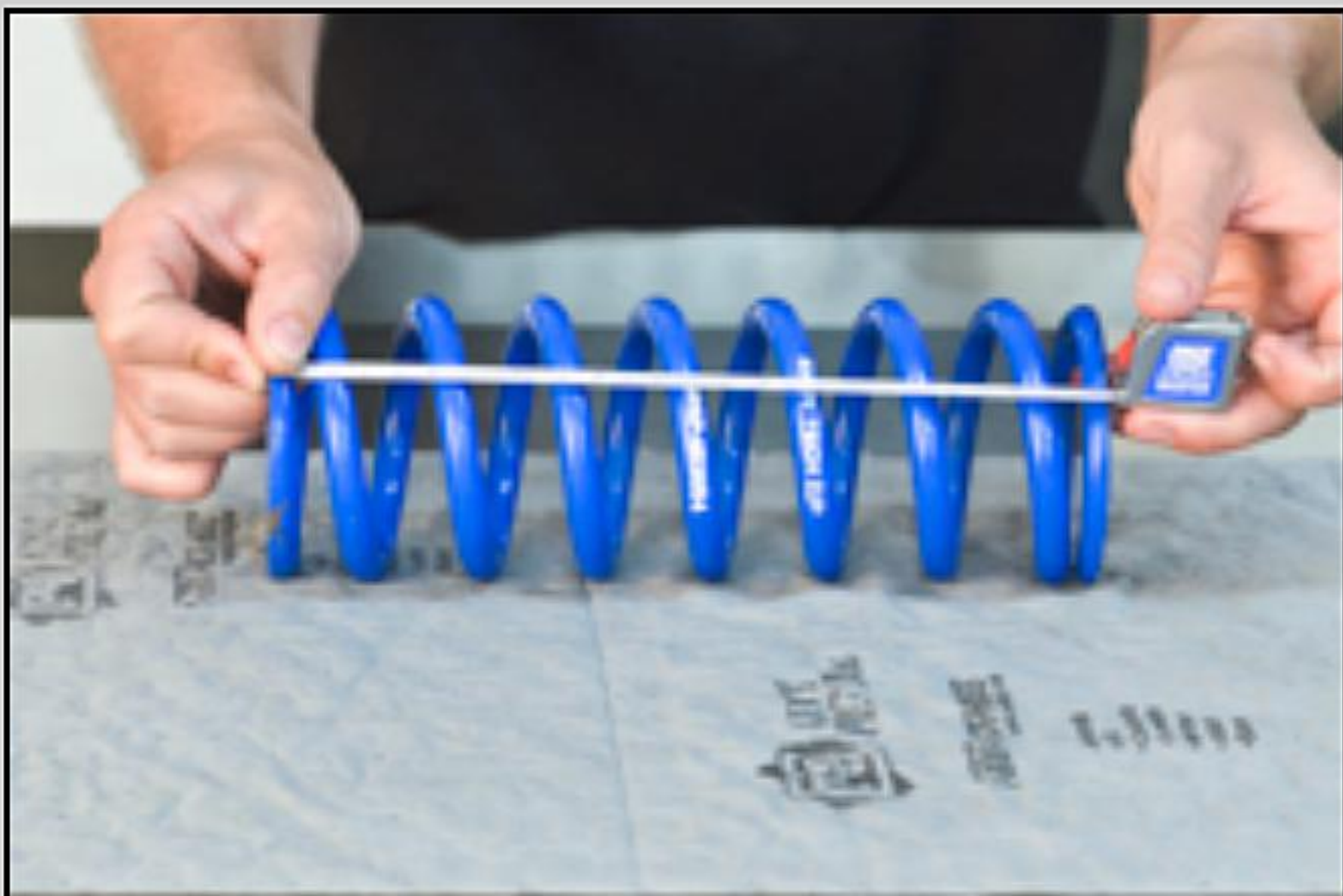

A23 - Measure the free length of the spring.



A24 - Install the spring.



A25 - Install the spring collar seat.



A26 - Install the spring collar and/or clip.



A27 - Set the preload according to the DVS by adjusting the preload collars.

Preload is the amount the spring is compressed from fully extended to get to its installed length.



A28 - Tighten the lock ring with the Shock Preload Adjuster Tool.



A29 - Push the bumper into the bumper cup.



A30 - Set the high-speed compression adjuster to the setting in the DVS.

Note - Unless otherwise instructed, all adjusters are counted as clicks or turns OUT from all the way in (clockwise). All the way in is zero.



A31 - Adjust low speed compression...

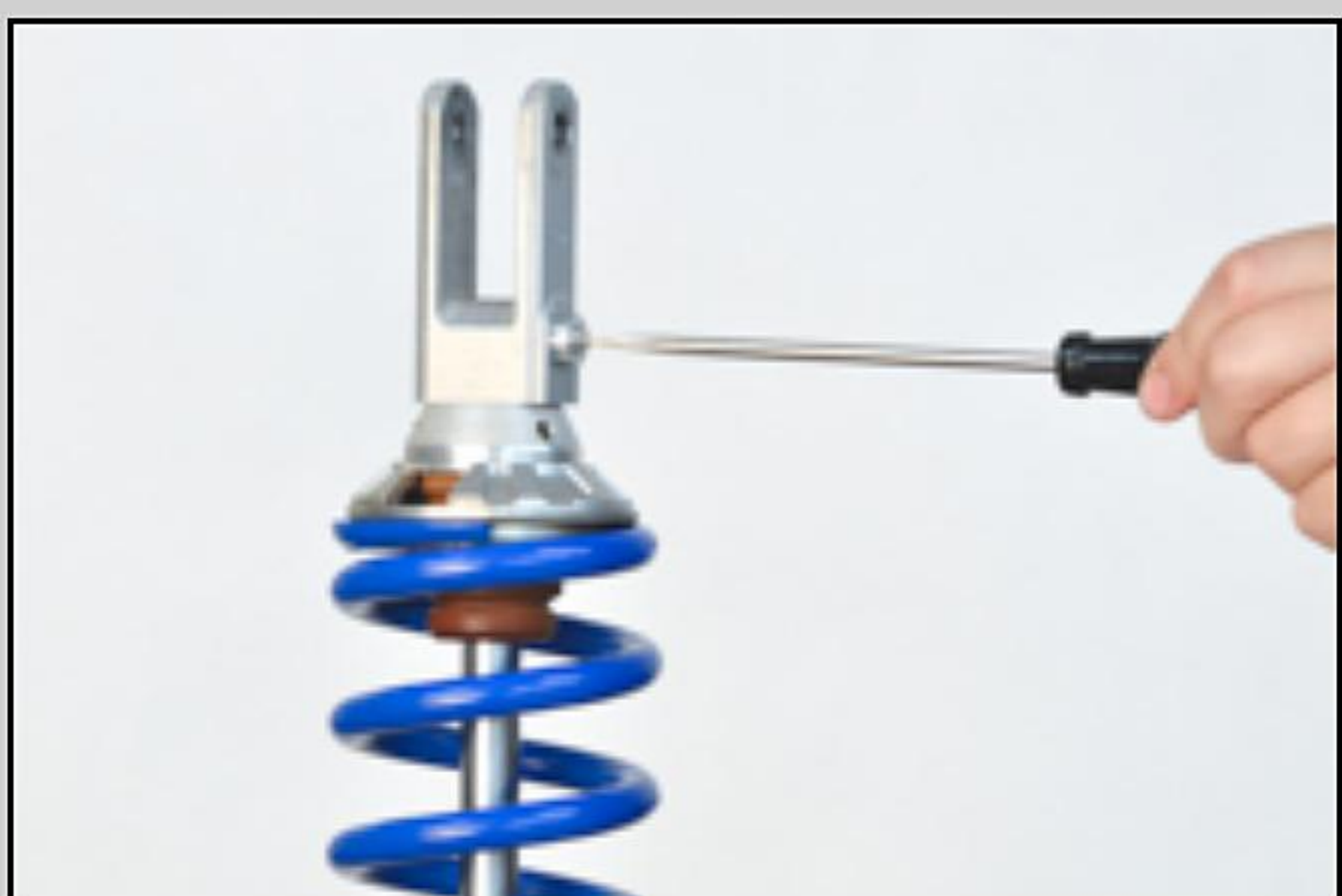

A32 - and rebound adjuster.



A33 - Make sure Spherical Heim Bearings at the mounting eyelets are greased and in good shape with no slop.

Chicks dig stickers!

Enjoy.

Shock Gold Valve Installation

VALVING INSTRUCTIONS - STANDARD

These instructions cover installation of the Shock Gold Valve onto the shaft for many types and brands of shocks. To get to this point in the installation see the

[DVS Setup Sheet](#) - If you haven't already, go to [DVS Valving Search](#), insert your [Access Code](#), and rider data and print your [DVS Setup Sheet](#).

Shortcuts:

- > [SHAFT DISASSEMBLY](#)
- > [SEAL HEAD REBUILD](#)
- > [SHAFT ASSEMBLY](#)
- > [VALVING](#)

CAUTION: IF YOU ARE UNFAMILIAR WITH REBUILDING AND REVALVING SHOCKS, STOP!!! DO NOT PROCEED; SEEK OUT A QUALIFIED SUSPENSION TECHNICIAN.

NOTE: All measurements are metric (for inches divide by 25.4). The valving list starts at the piston face and goes towards the Base Plate. Valve specs are listed by (QUANTITY) THICKNESS x DIAMETER. A number in parentheses means quantity. If there is no number in parenthesis the quantity is one. Example: (2).15x30 means quantity two, 15 hundredths of a millimeter thick by 30 millimeters in diameter.



Tools

- Torque wrench (SnapOn Digital Torque Wrench shown)
- Metric calipers and micrometer
- [TMVJ 065 Vise Jaws](#) mounted on a Vise - suggested
- [TSSB Series Bullet Tool](#) - for Seal Head installation
- [TSCP 01](#) - Clip Tool
- [TSSS Series](#) - Seal Head Setting Tool

Supplies

- Contact Cleaner - or other good, clean solvent
- Loctite - Hi-Strength (included in the Gold Valve Kit)
- [USSG 01](#) - Ultra Slick Seal Grease

SHAFT DISASSEMBLY

SD1 - Remove the shock shaft nut. On Showa and KYB shocks the nut is peened on. This peening must be removed first.

KYB shocks - On almost all KYBs the peening can be ground or filed off flat. (Except for 1989 YZ125 & 250, 1989-91 CR125, and 91 CR250 & 500. See your DVS Sheet.)

WP, Sachs, and Ohlins are not peened and can be removed with a wrench.

SHOWA NUT REMOVAL

On Showa shocks, the peening also retains the rebound adjuster hardware inside the shaft. **The peening should only be removed on the OD where it retains the nut.** The peening on the ID must be left intact where it holds in the rebound mechanism.

Remove the peening with a file (you can use a bench grinder too if you're careful.) Remove material only on the outer diameter just enough to remove the nut.

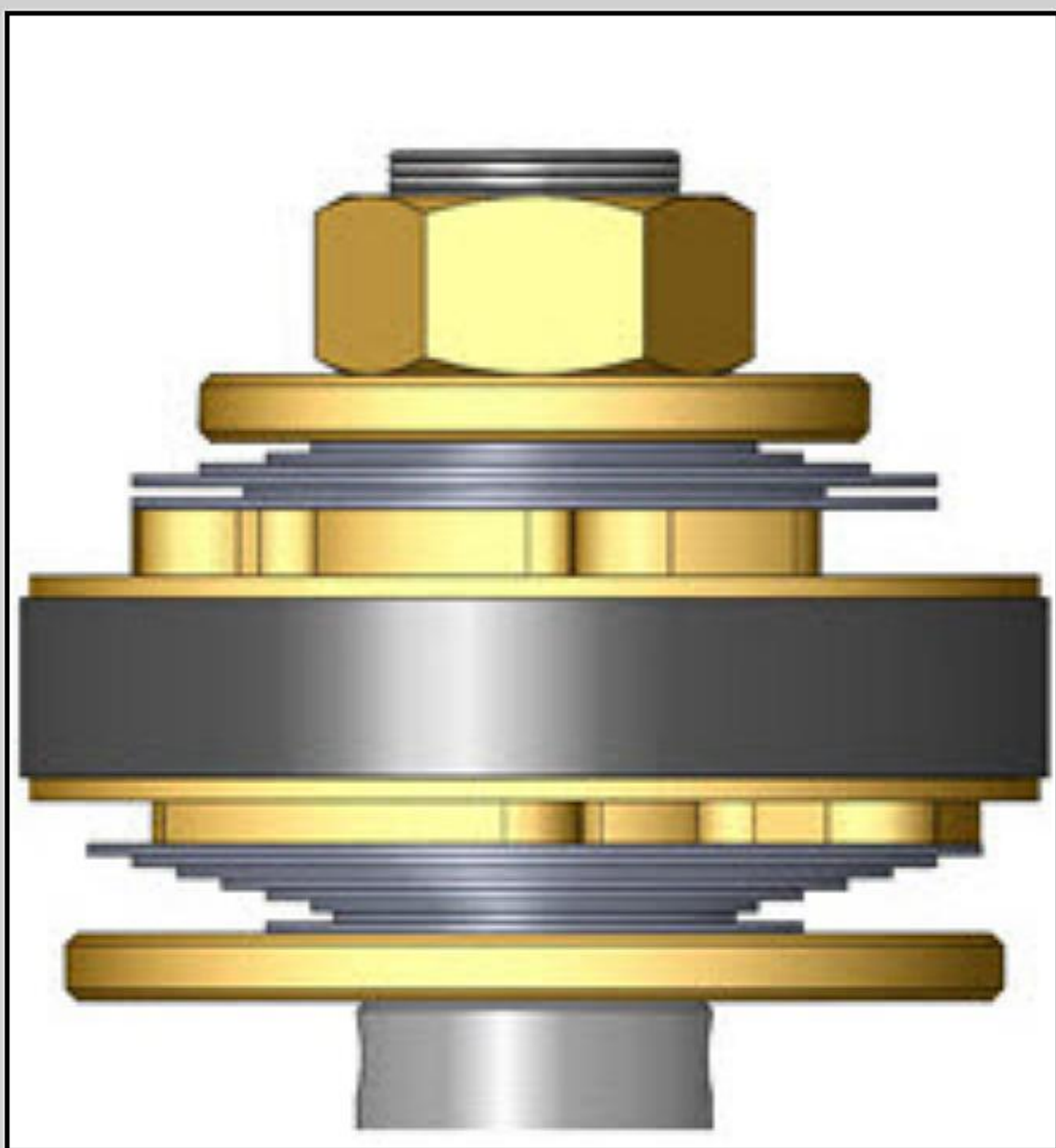

Showa with peening on



Removing the peening with a file.

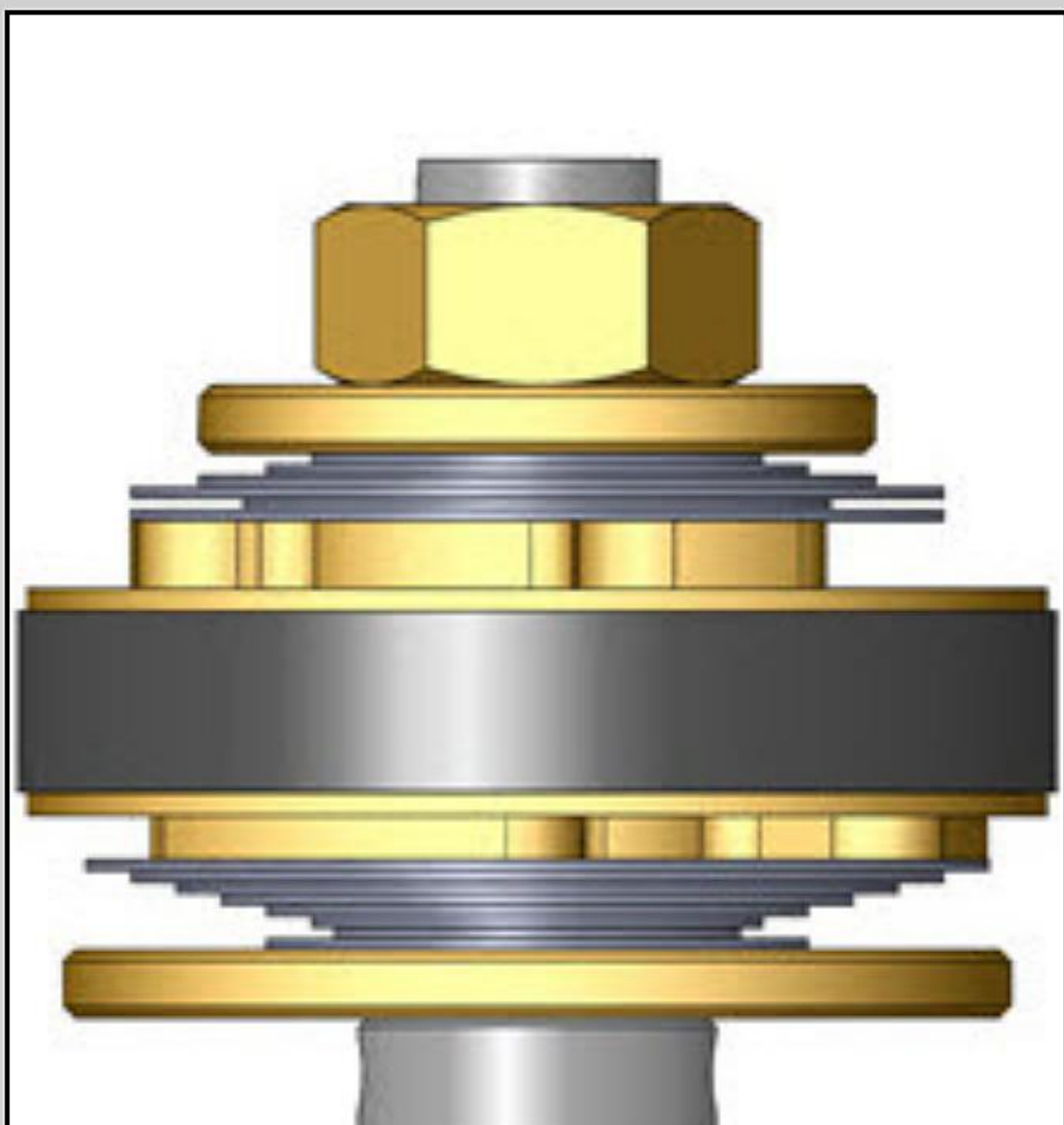

Showa with peening removed

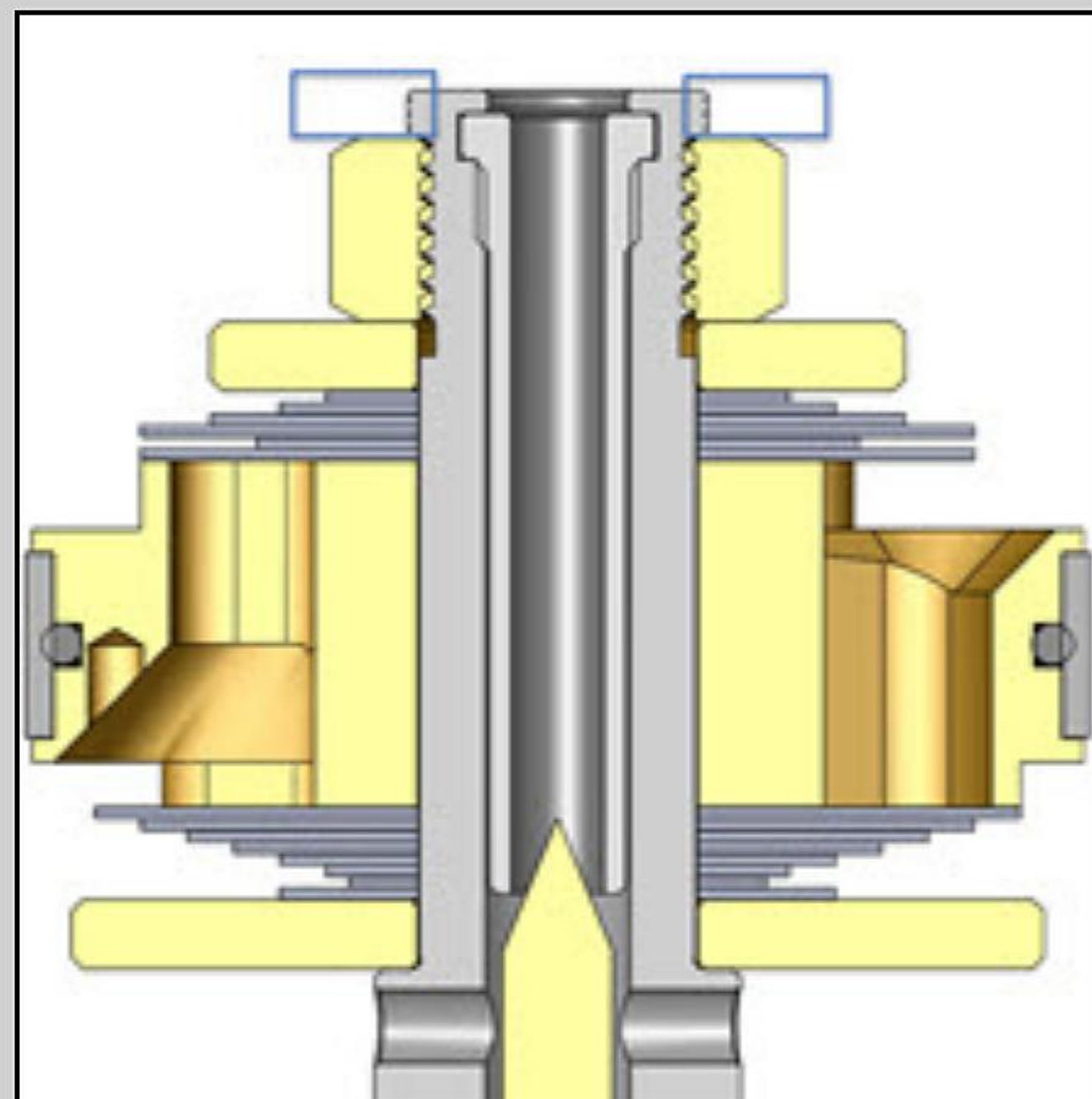

Showa's peening retains the internal rebound hardware. Do not remove this internal peening.

Blue boxes indicate peening that must be removed around the OD only.

SD2 - Remove the shock shaft nut and the valving stack.



SD3- For peened-on nuts, chamfer the end of the thread with a file or a grinder just enough to clean up the sharp edge. Deburr with a wire wheel.



SD4- To remove filings, blow air through one of the side feed holes with a rubber tipped blow gun while covering up the other side. Use contact cleaner and repeat.





SD5- Remove the seal head, body cap, bottom-out bumper and retaining cup. Some models have slightly different hardware.

Inspect the Bottom-out Bumper for tears or damage. Bumpers are wear items. They break down over time and should be replaced when any signs of deterioration exist.

Bumpers are available at Race Tech.

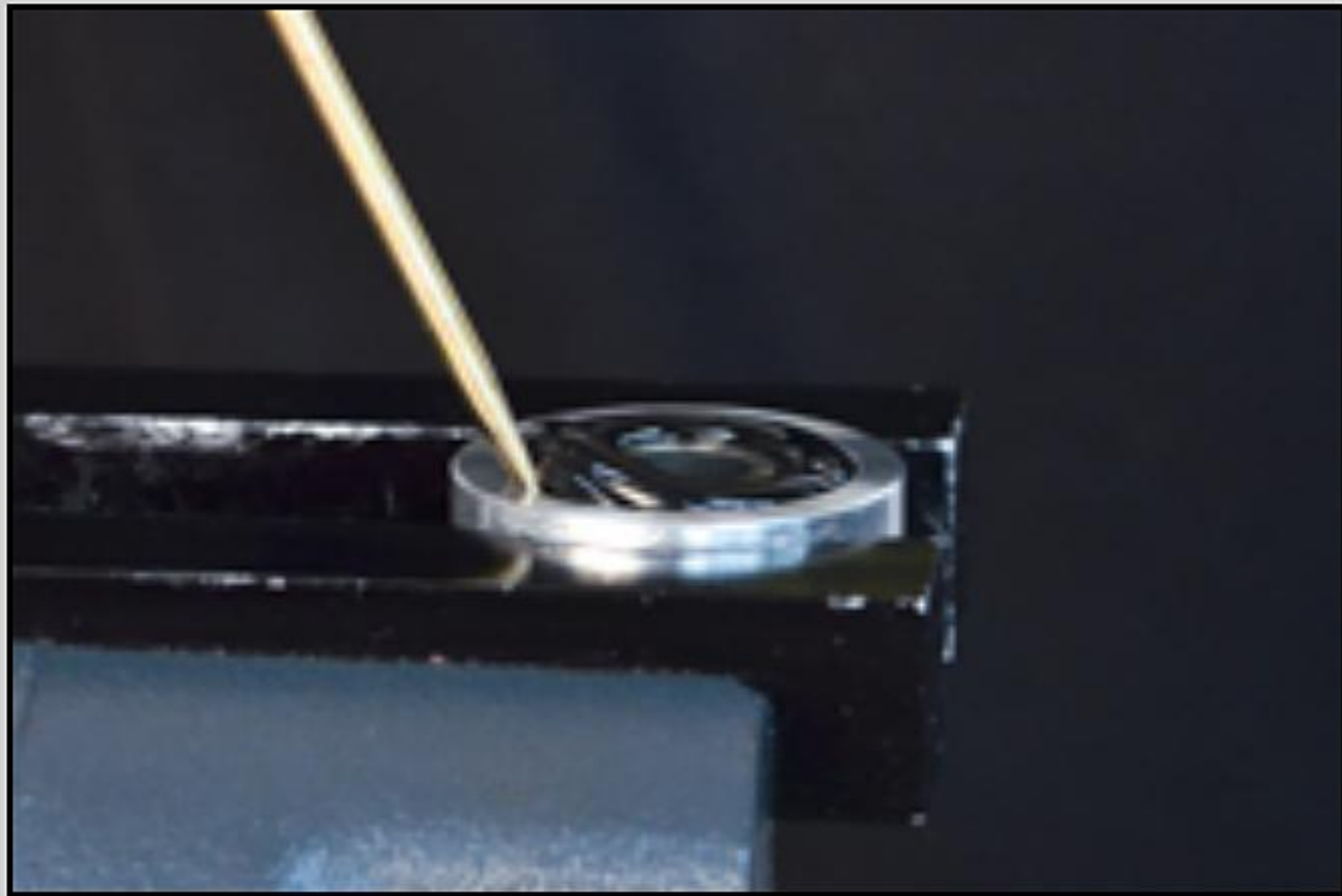

SEAL HEAD REBUILD

SH1 - This is only required if replacing a seal or shaft bushing. Shock Seals can last a long time but it is a good practice to replace both the Shaft Seal and Dust Seal together if they are over a year old.



SHAFT ASSEMBLY

SA1 - Install the bumper cup, bumper, and body cap.

SA2 - Lube the seal with Ultra Slick Grease (USSG 01).



SA3 - Reinstall the Seal Head. It is best to use a Shock Seal "Bullet" Tool (TSSB Series) to protect the seal.



SA4- Install the Base Plate on the Shaft.

There are models that require 2 or even 3 Base Plates to create the correct Total Valve Stack Height. The original Base Plate goes on first. Any additional Base Plates or Spacing Shims go on next. See step V8.

Note - Some shocks with a top-out spring use a shim under the Base Plate. If your shock has this configuration, re-install the shim first.



V1- VALVING

First build and install the Compression Valving Stack onto the shaft. Next goes the Gold Valve with the large shim side down against the Compression Stack and then the Rebound Stack.

VALVING STACK TYPES - SINGLE OR TWO STAGE

V2- You will either be building a Single Stage or a Two Stage Stack (or possibly a combination of both). The difference is the Crossover. The Crossover is a smaller diameter shim between the Lo-Speed and the Hi-Speed Stacks.

Note: The DVS Custom Setup Sheet displays individual shims and does not label Hi-Speed, Crossover, and Lo-Speed. This is for your information only. Also you will not use all the shims provided in the Gold Valve Kit.

- **Single Stage** - made of:
Lo-Speed Stack
Hi-Speed Stack

There is NO Crossover
(it becomes one stack.)

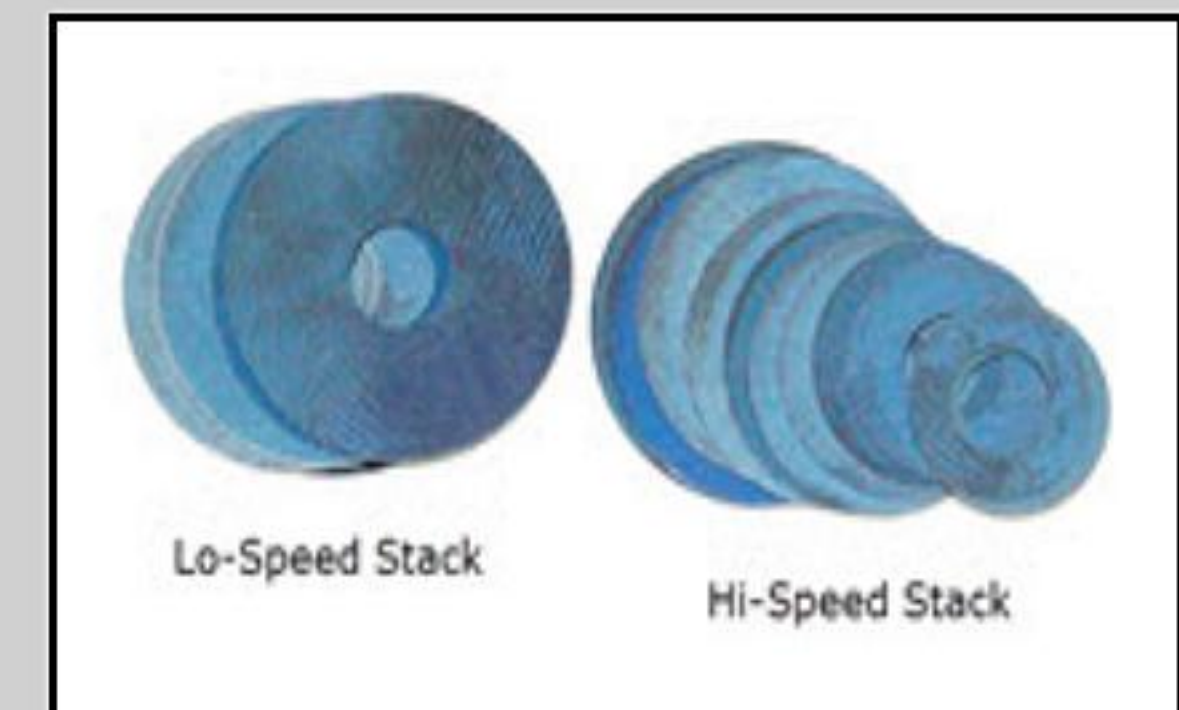
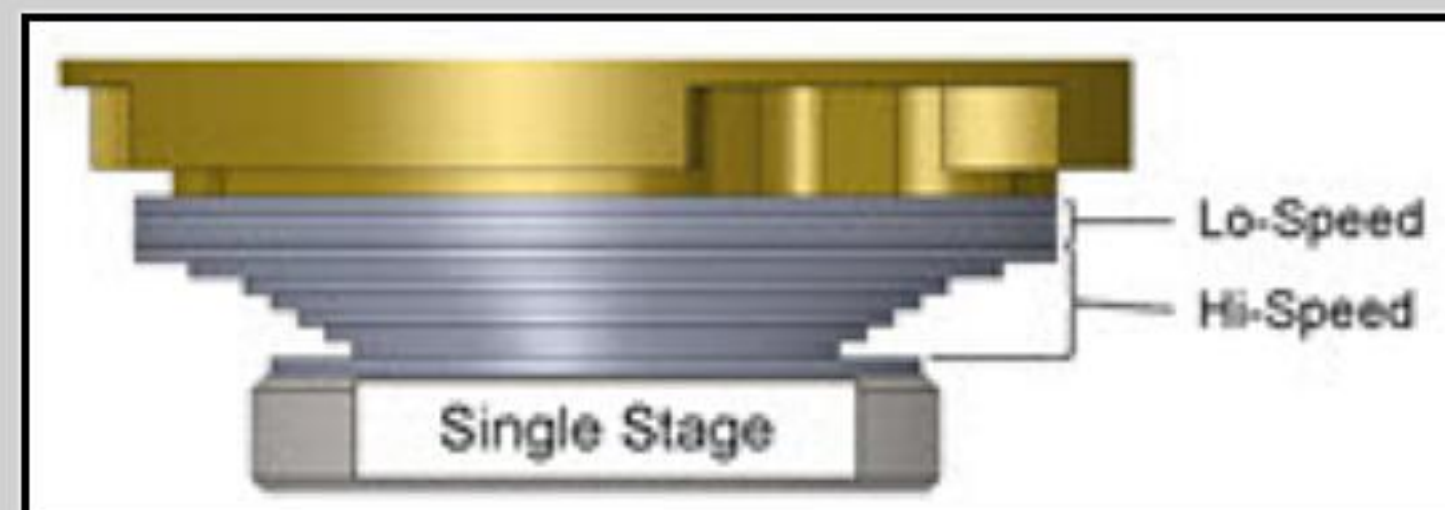

- **Two Stage** - made of:
Lo-Speed Stack
Crossover
Hi-Speed Stack

The Crossover Gap is visible

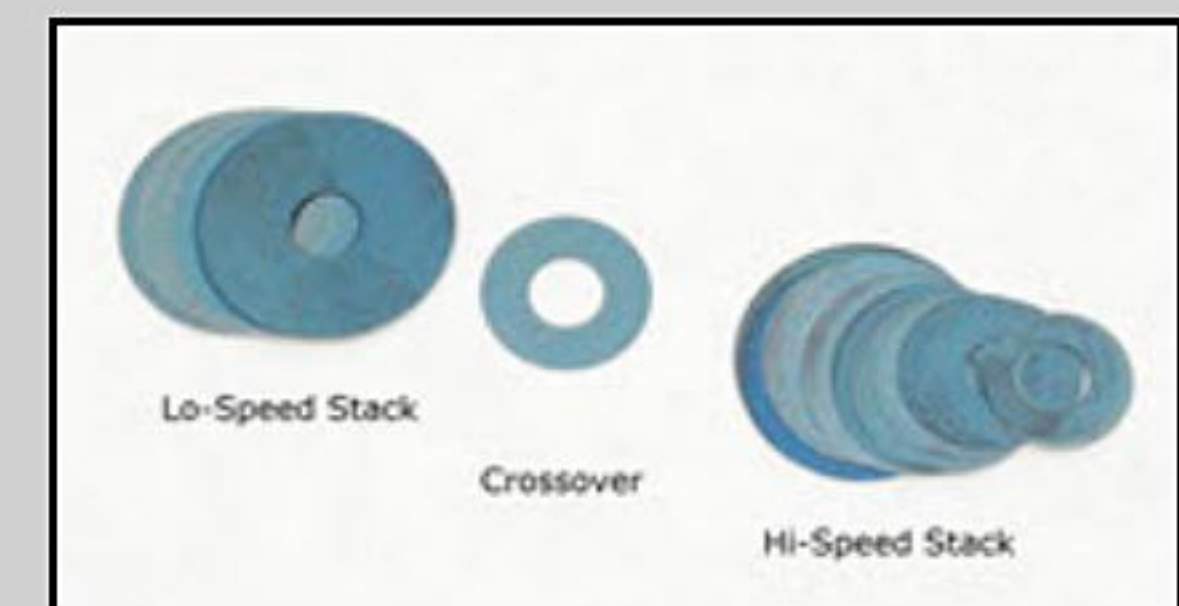
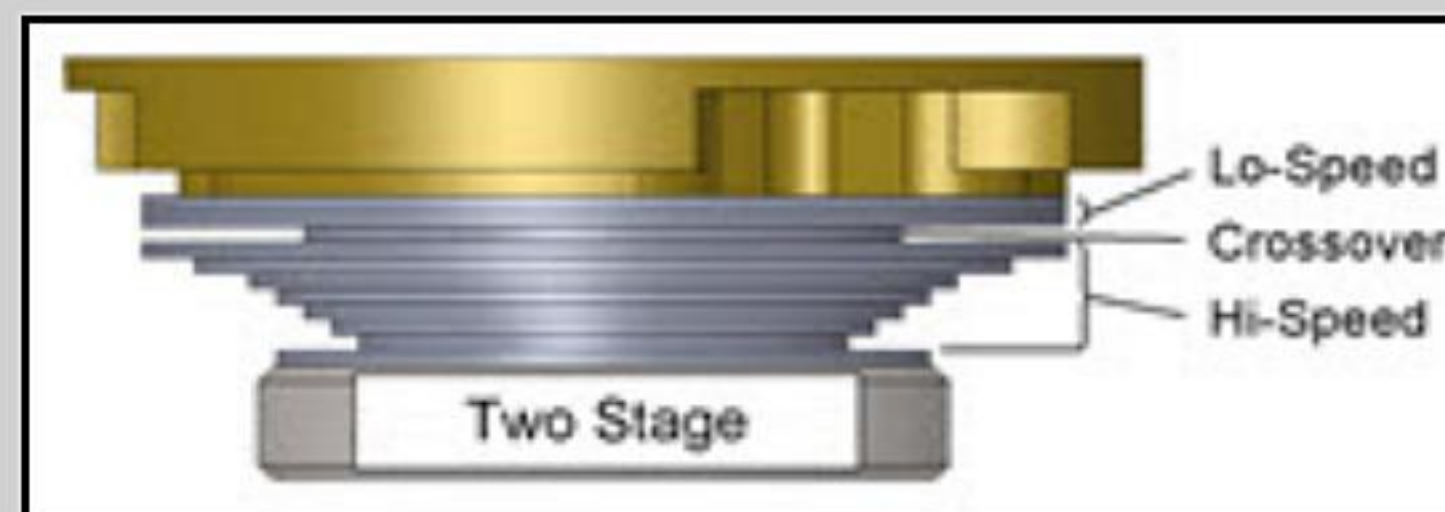

TWO STAGE

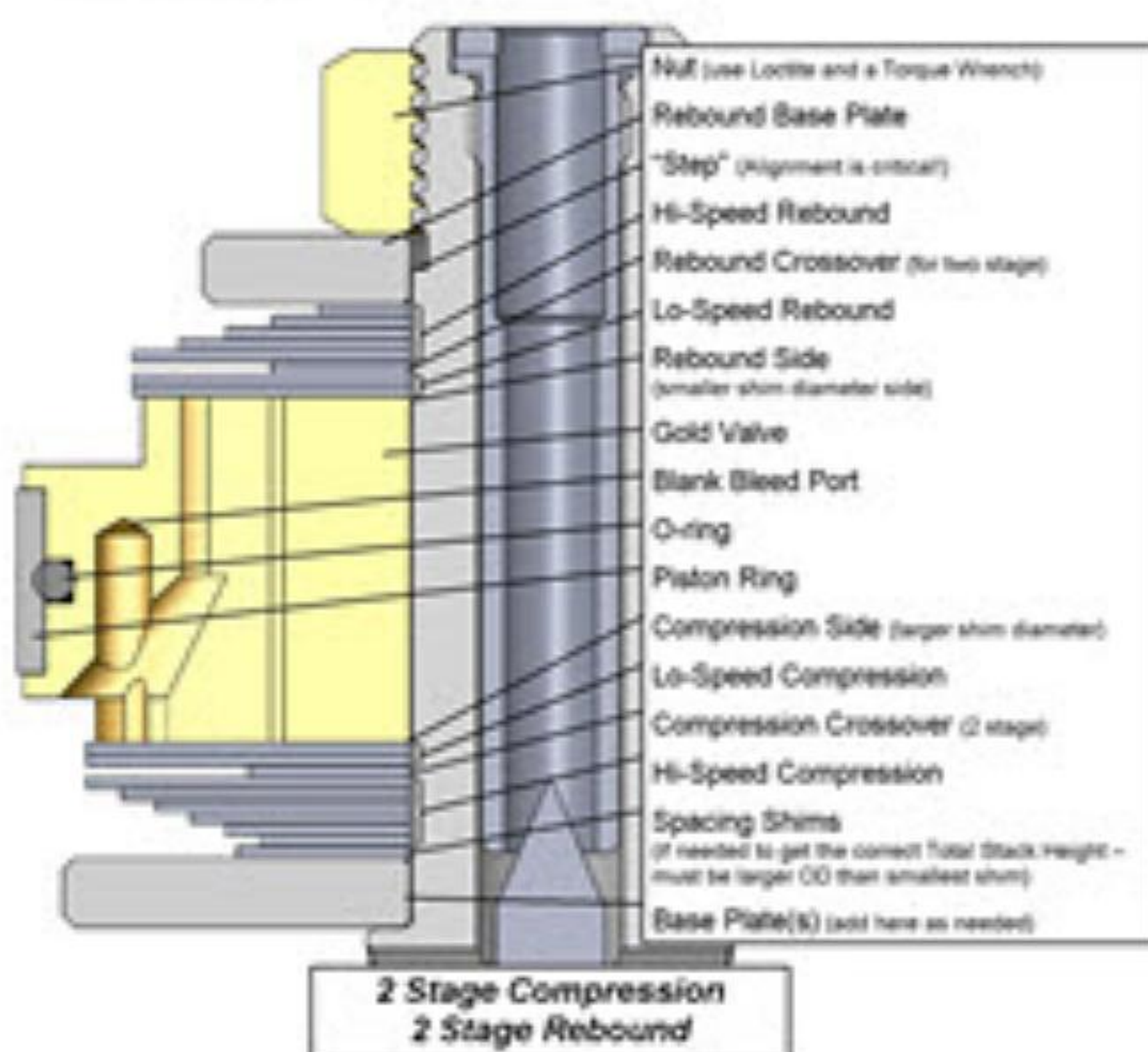

V3- Two Stage Example

(Single Stage is exactly the same except there is no Crossover)

For Two Stage the total valving stack is made up of a:
Lo-Speed Stack
Crossover and a
Hi-Speed Stack

(this is only an example - not your setting)

The Total Valving Stack starting from the Gold Valve piston face:

- (4) .20x44 - Lo-Speed Stack
- (1) .15x28 - Crossover (notice the smaller diameter)
- (1) .25x44 - Hi-Speed Stack

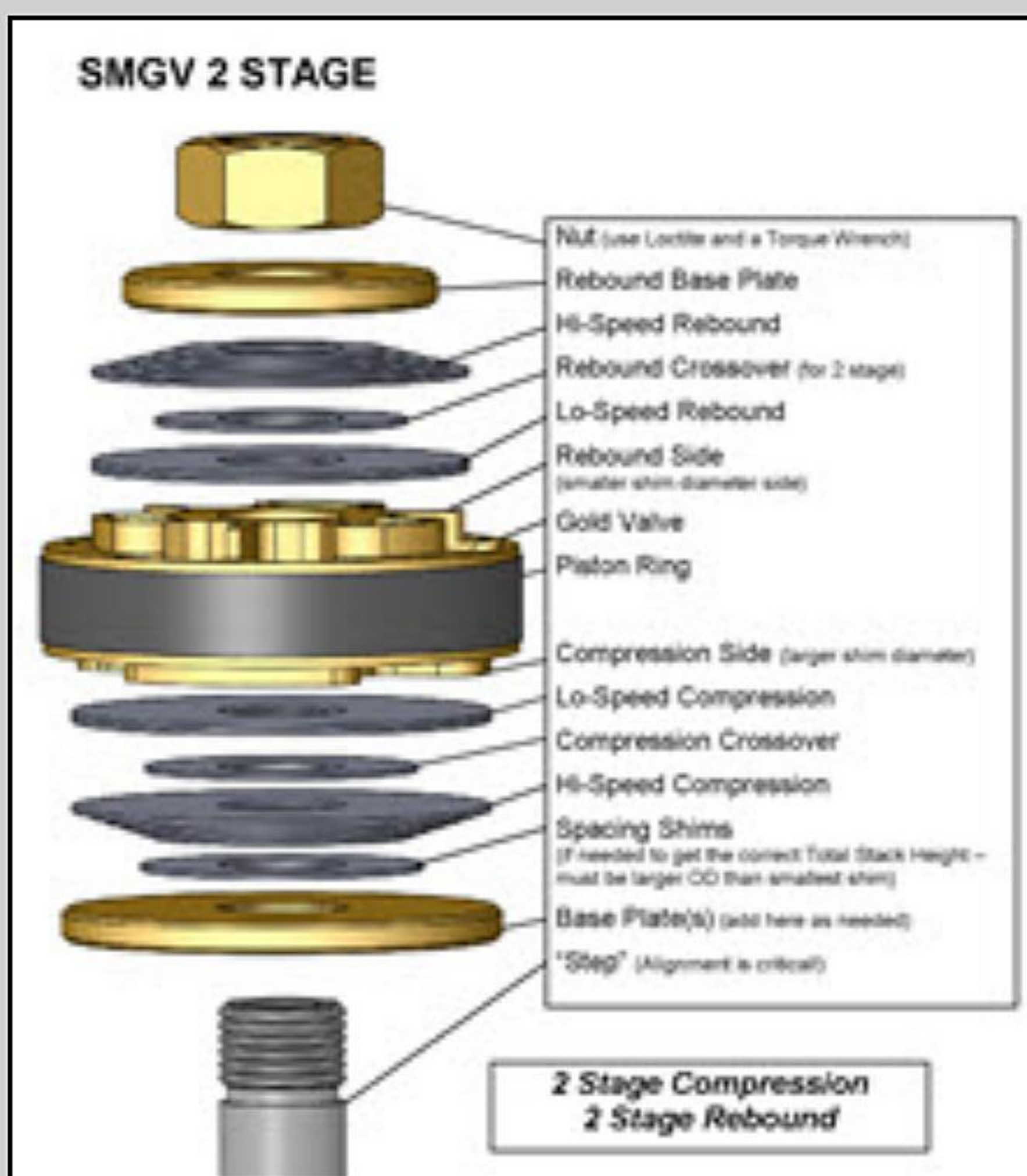

- (1) .25x42
- (1) .25x40
- (1) .25x38
- (1) .25x36
- (1) .30x34
- (1) .30x32
- (1) .30x30
- (1) .30x28
- (1) .30x26
- (1) .30x24
- (1) .30x22



V4 - Install the compression valving stack **in the reverse order that it is listed**, starting with the last (smallest diameter) shim of the Hi-Speed Compression Stack directly on the Base Plate and ending with the largest diameter shim of the Lo-Speed Compression Stack.



V5- **BLEED HOLE (or no bleed hole)**

If the DVS does not call for a Bleed Hole (it says "n/a" for Bleed) skip this step.

If your DVS Setup Sheet calls for a Bleed Hole, drill it to the recommended size. To make drilling the Bleed Hole easier, most Gold Valves have a blank pilot hole or holes.

How many holes? - The DVS tells how many Bleed Holes to drill. Most of the time it is one. If there is a number in parenthesis before the hole size this is the quantity i.e. (2)1.3mm (#53) means two bleed holes. Otherwise the quantity is one.

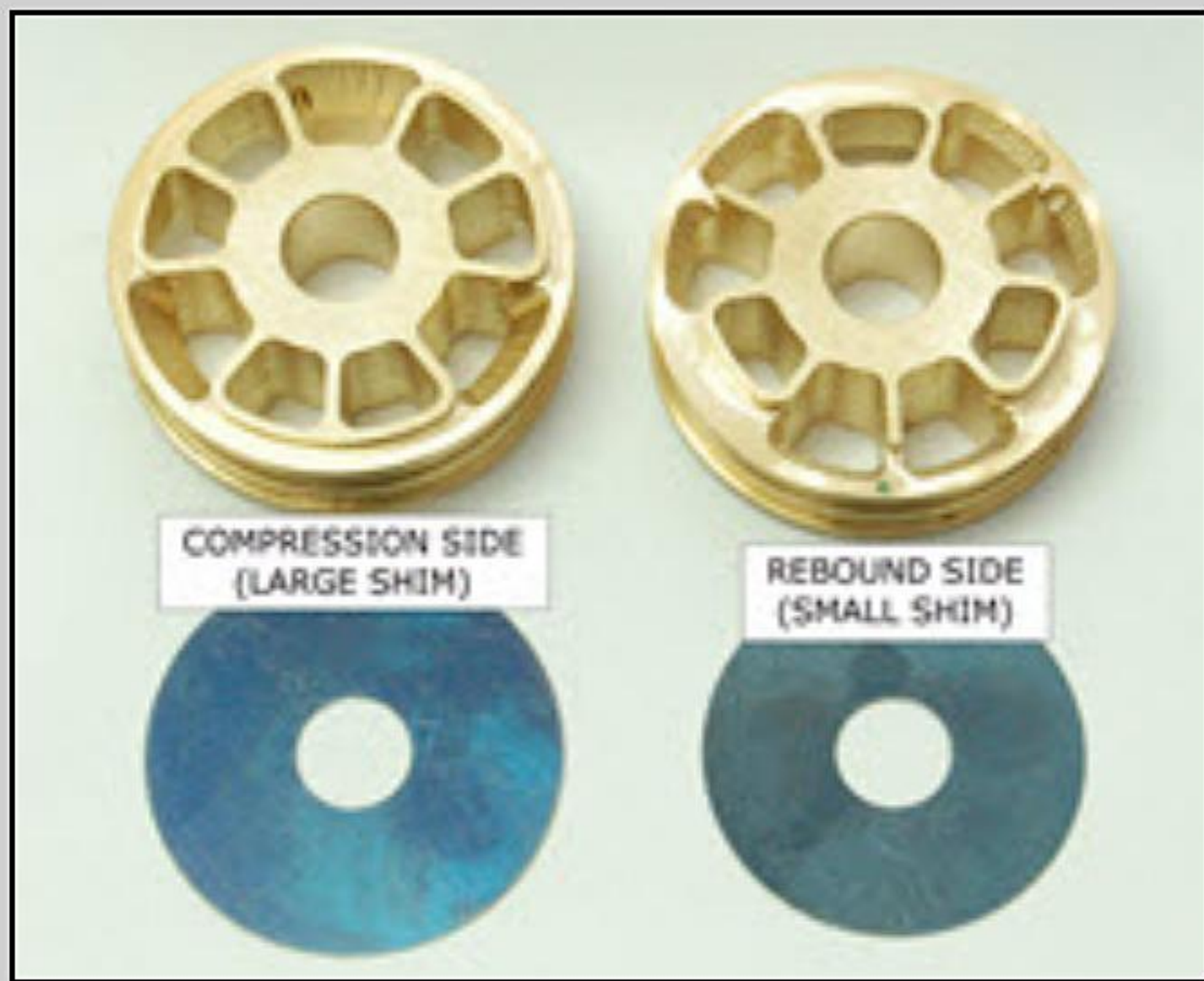

V6- Install the Gold Valve with the compression side of the piston (larger shims) down towards the compression valving stack.

The rebound side of the piston (smaller shim side) is shown on the right. Note the compression side on the left has larger ports and uses larger diameter shims than the rebound side.



V7- Install the Rebound Valving Stack in the **order** listed starting with the largest diameter shim and ending with the smallest diameter shim.

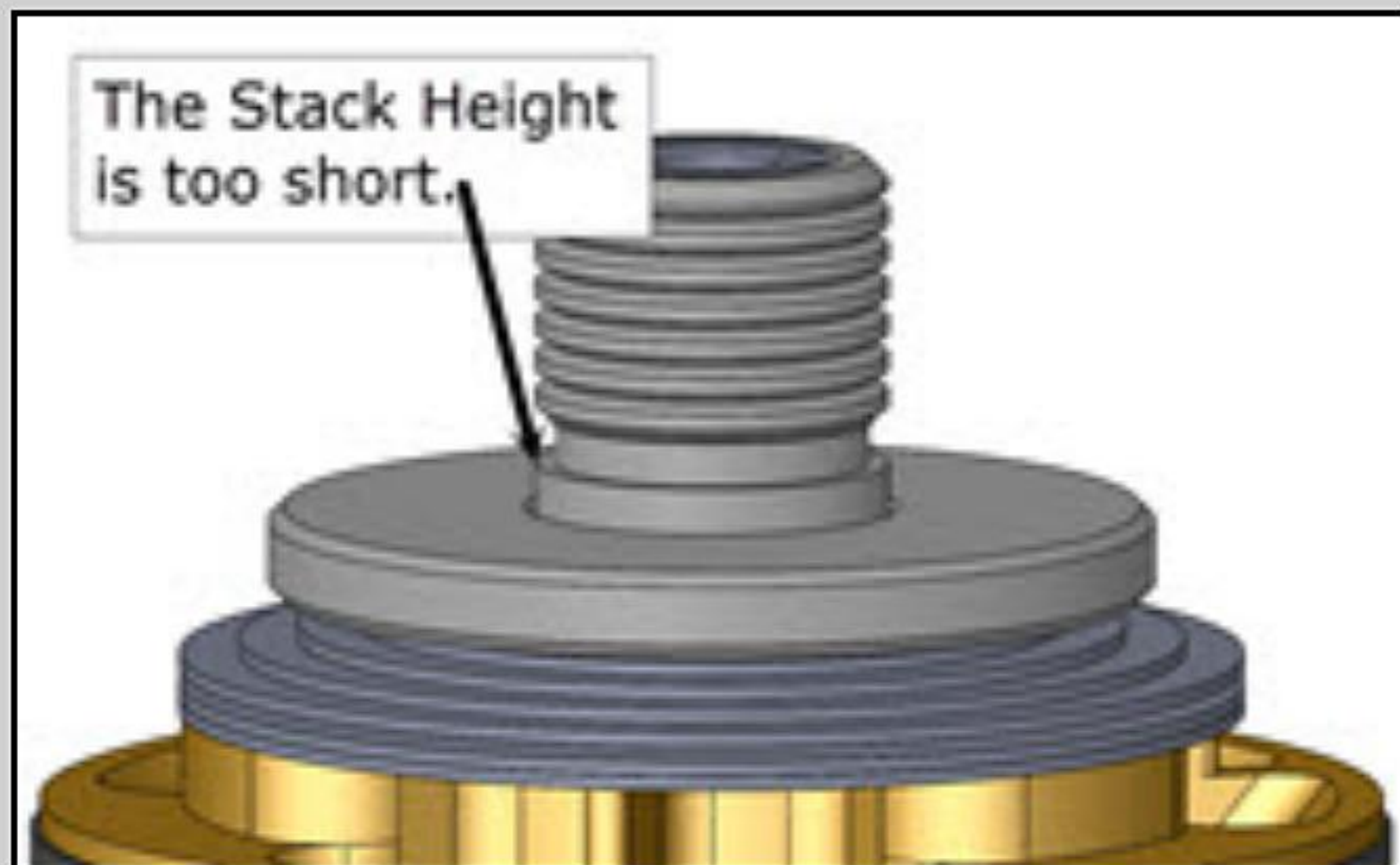

V8- **Make sure the Total Valving Stack Height is correct. Critical!!**

This step is here to insure you don't "run out of thread" onto the straight, non-threaded, portion of the shaft when tightening the Nut and the Nut gets full engagement.

The shims should be guided with the straight, non-threaded part of the shaft and should not be on the thread. **The Rebound Base Plate should cover or "straddle" the "step" at the end of the thread.**

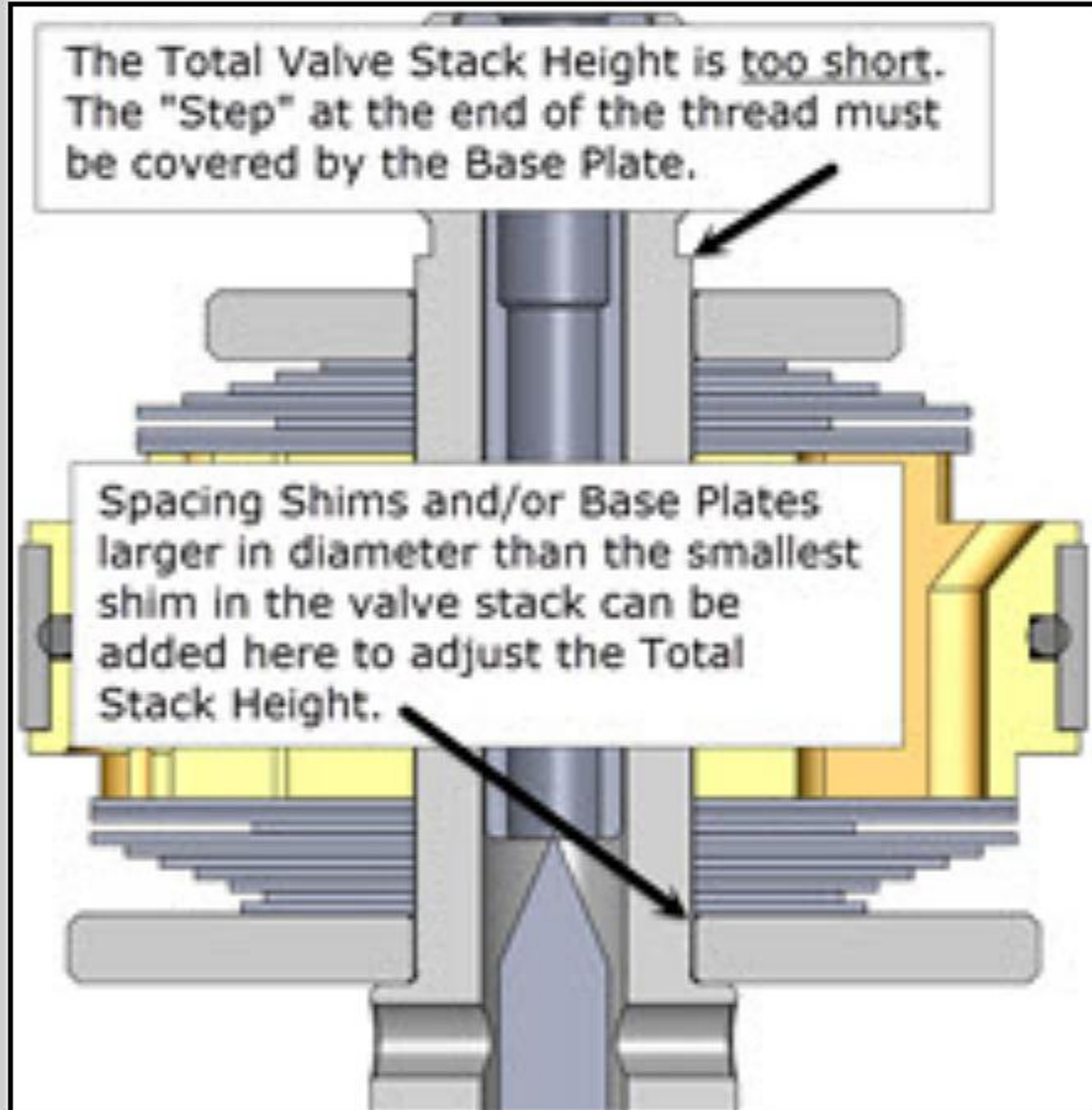

Incorrect stack height is shown in this photo (this stack is too short).

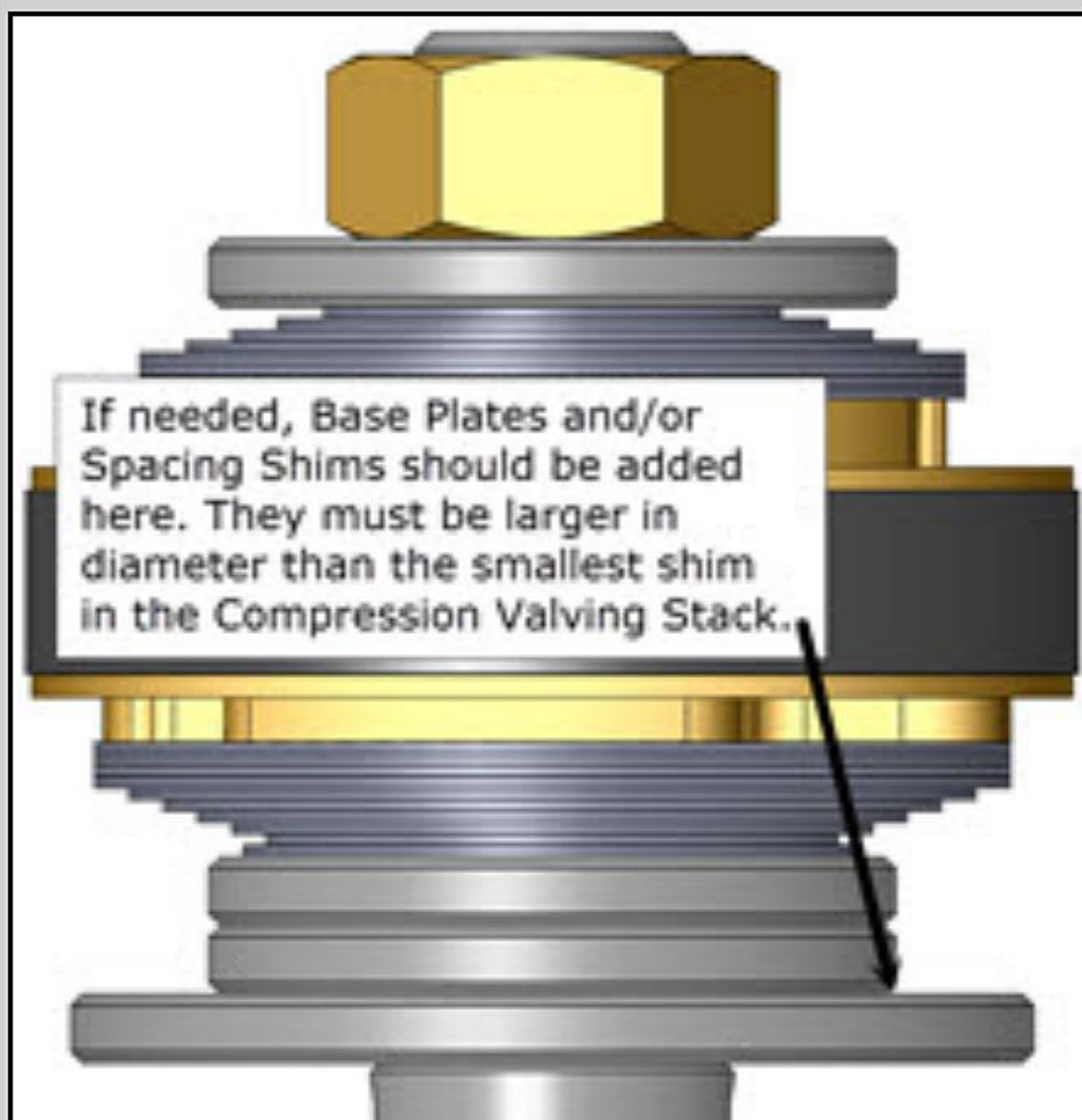

Base Plates can be added if required.

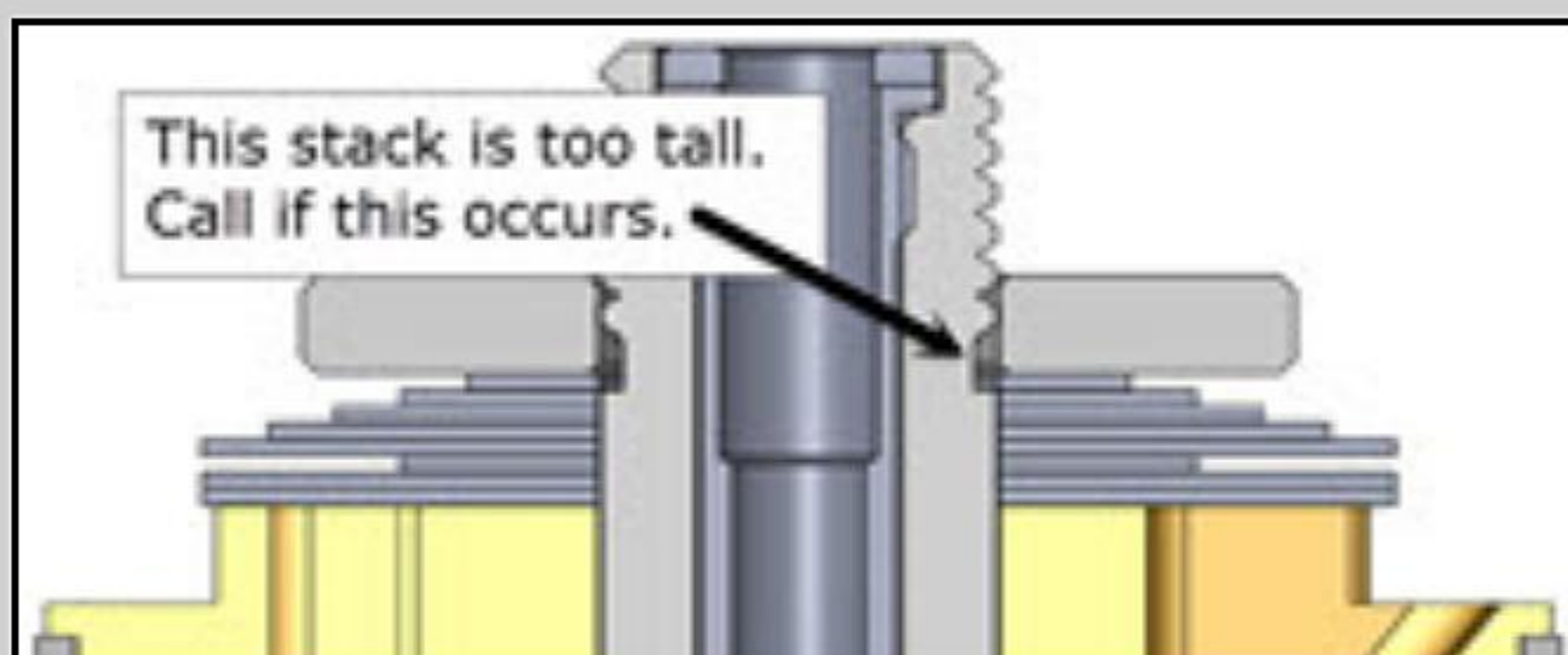

This stack height is too tall. Call Tech Support if this occurs.

If needed, height adjustment is done with Spacing Shims added just below the Rebound Base Plate.

Spacing Shims must be larger in diameter than the smallest shim in the stack. Sometimes this is best accomplished by adding additional Base Plates.

Click images to enlarge.

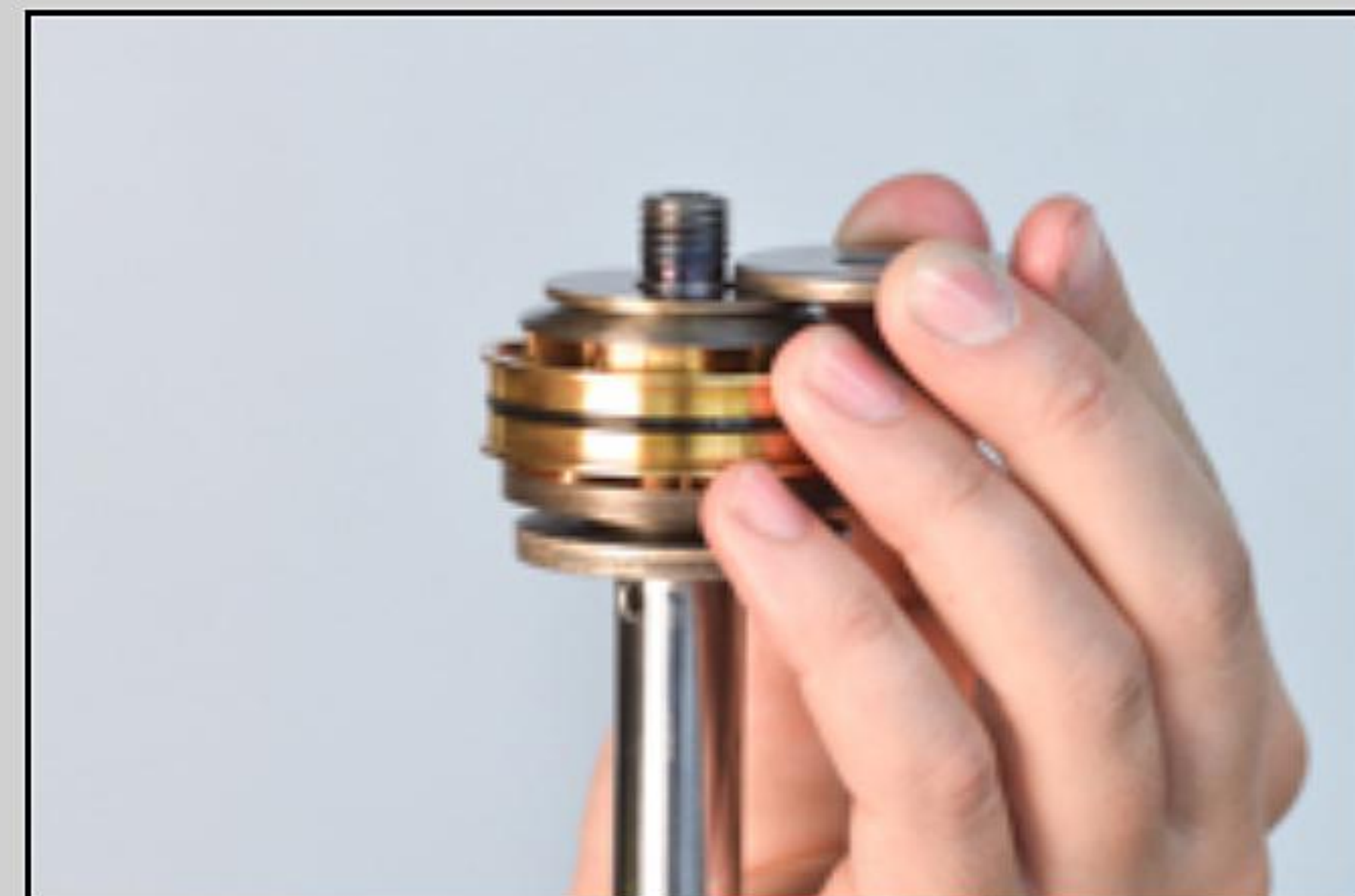
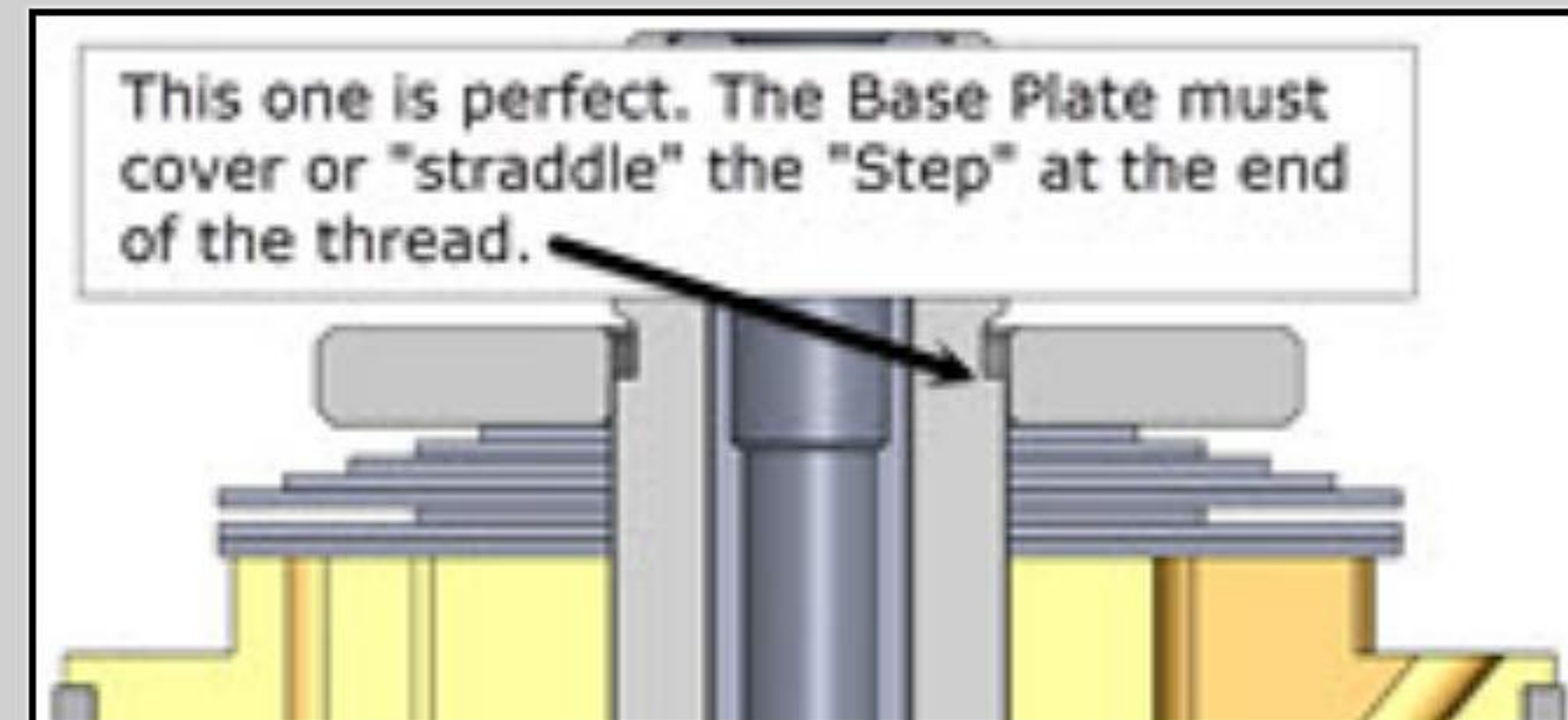

WP SHOCK SHAFT NUT

(direction is important)

EXTERNAL
HEX RELIEF

INTERNAL
THREAD RELIEF

V8a- WP Shock Shaft Nuts

WP Shock Shaft Nuts can be slightly different. The ones that have an External Hex Relief usually have a 2mm Internal Thread Relief. This means the end of the thread can be as much as 1mm above the Base Plate when installed.

Be very careful not to run out of thread. Use Loctite and a Torque Wrench.

V9- **Make sure you select the proper nut.** In many Gold Valve Kits more than one thread pitch nut is included and sometimes the stock nut is reused.

Ohlins, Sachs, and WP shocks reuse the stock nut.

Clean everything completely. Use Hi-Strength Loctite (included) on the shaft nut.

V10- **Install and torque the shaft nut to the proper setting (see the DVS) using a torque wrench. This is critical!**

V11- Single Stage Compression and Rebound

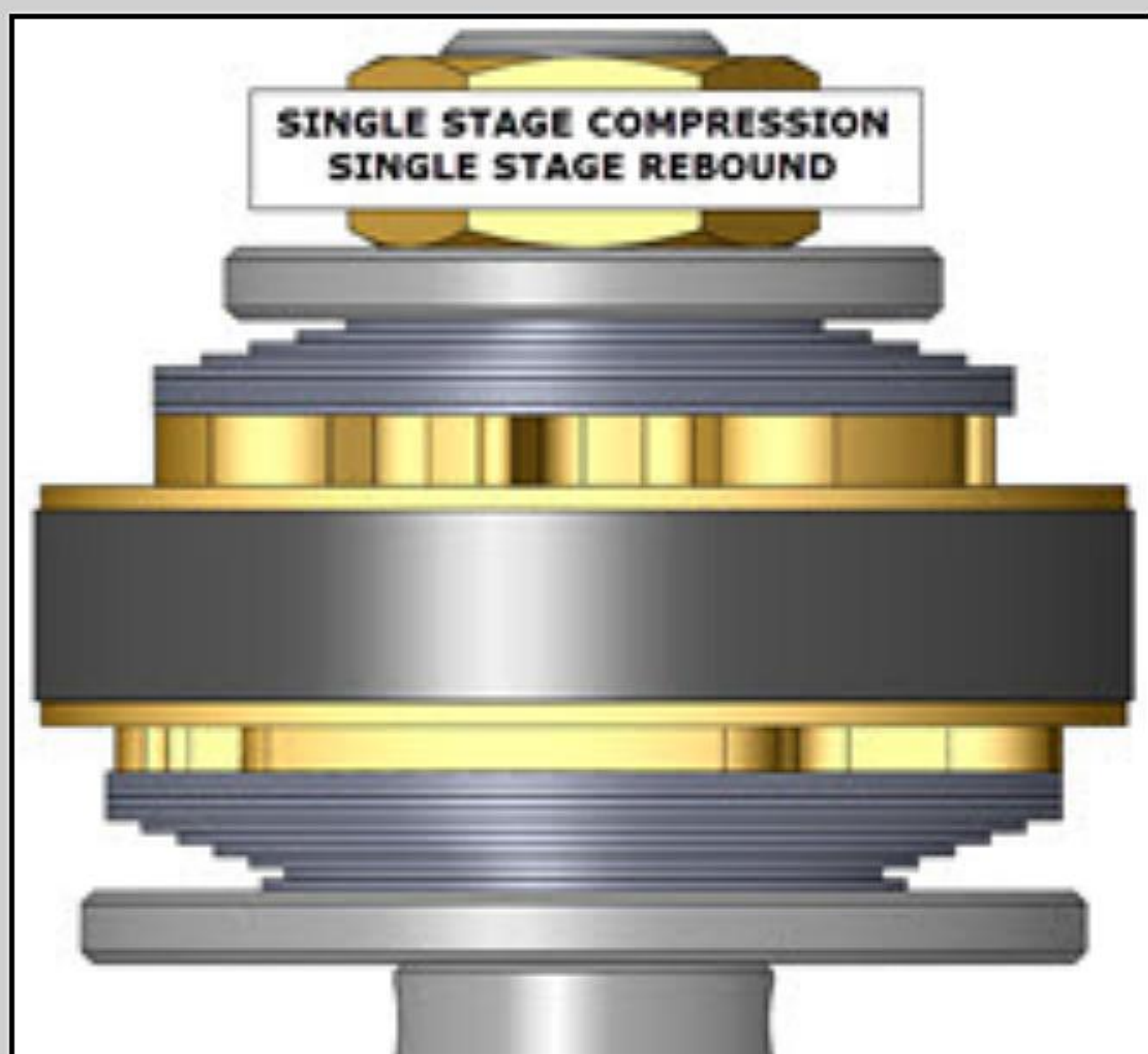

V11- Two Stage Compression and Rebound

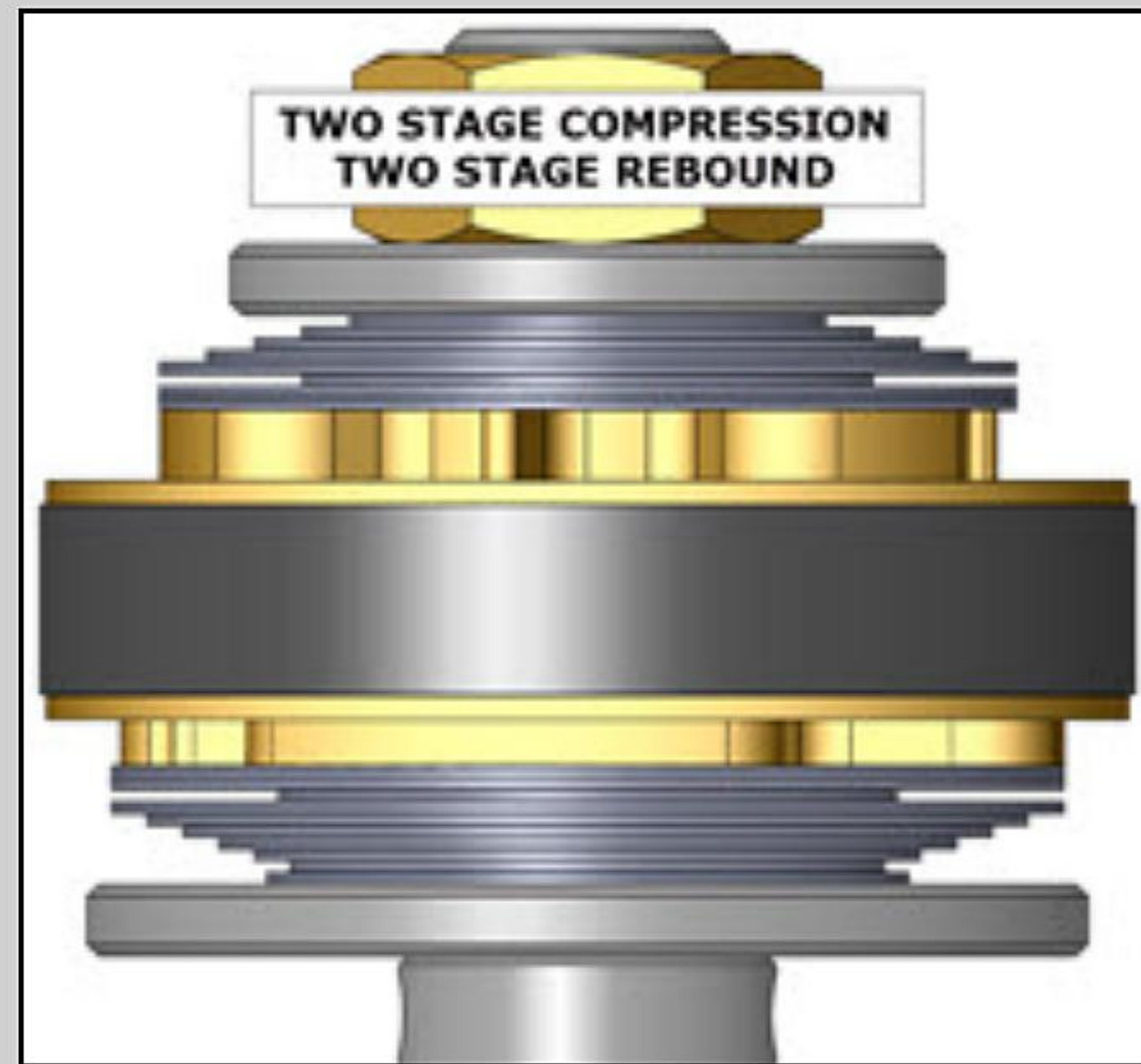

Notice the gap in the valving stack where the Crossover is. The Crossover Gap should be clearly visible.

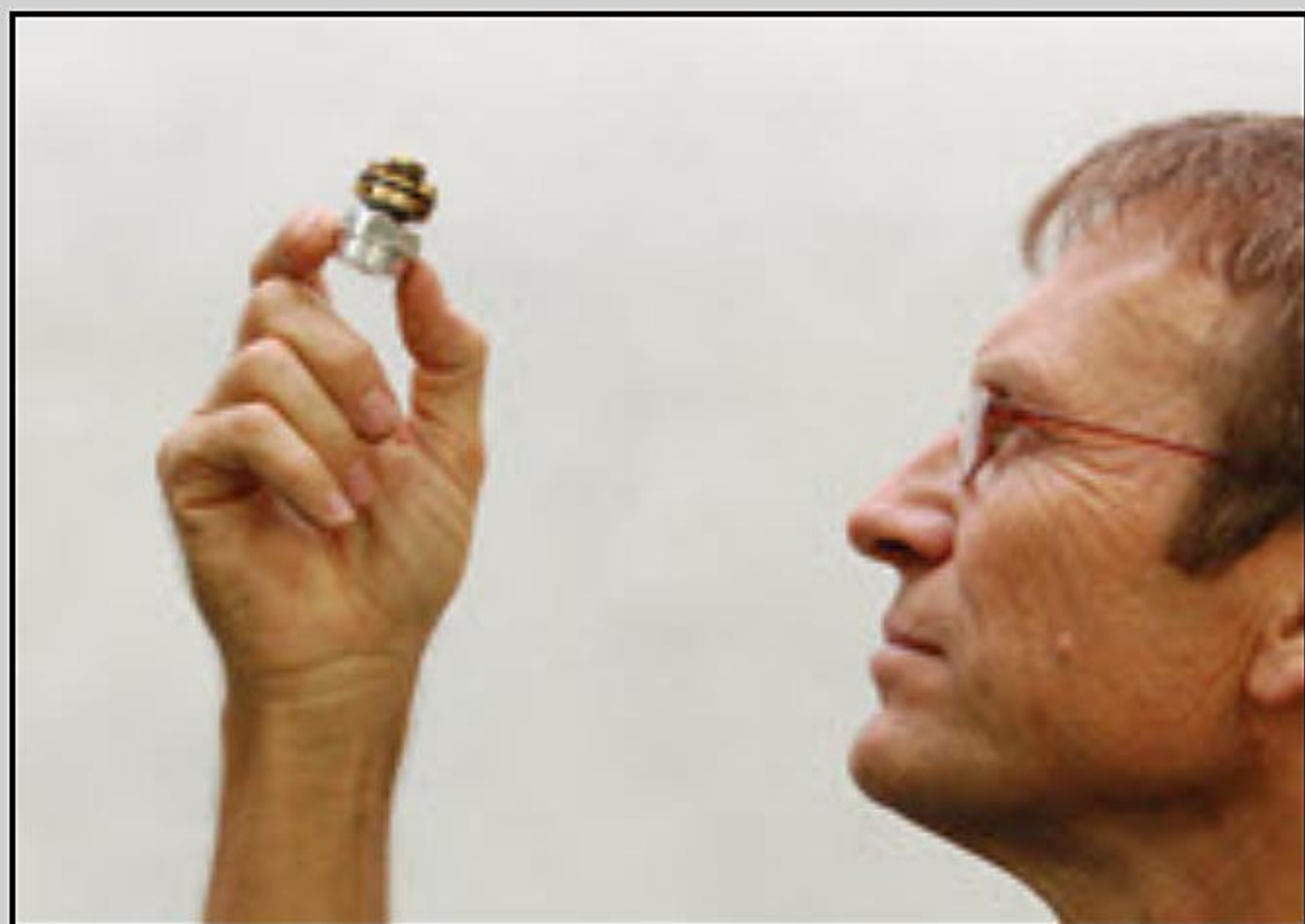

V12- Visually check your work.

Hold the completed valving assembly up to the light and look for any irregularities. Make sure the shims are laying flat on the piston surface. On two stage stacks check that the Crossover Gap is clearly visible.

If there are any problems, disassemble the stack and look for dirt, bent shims, or any other causes. Reassemble and inspect again.

You might be thinking that this looks like either a very tiny shock shaft or a fork compression valve. Well, you're right, it's a very tiny shock shaft. You get the idea.

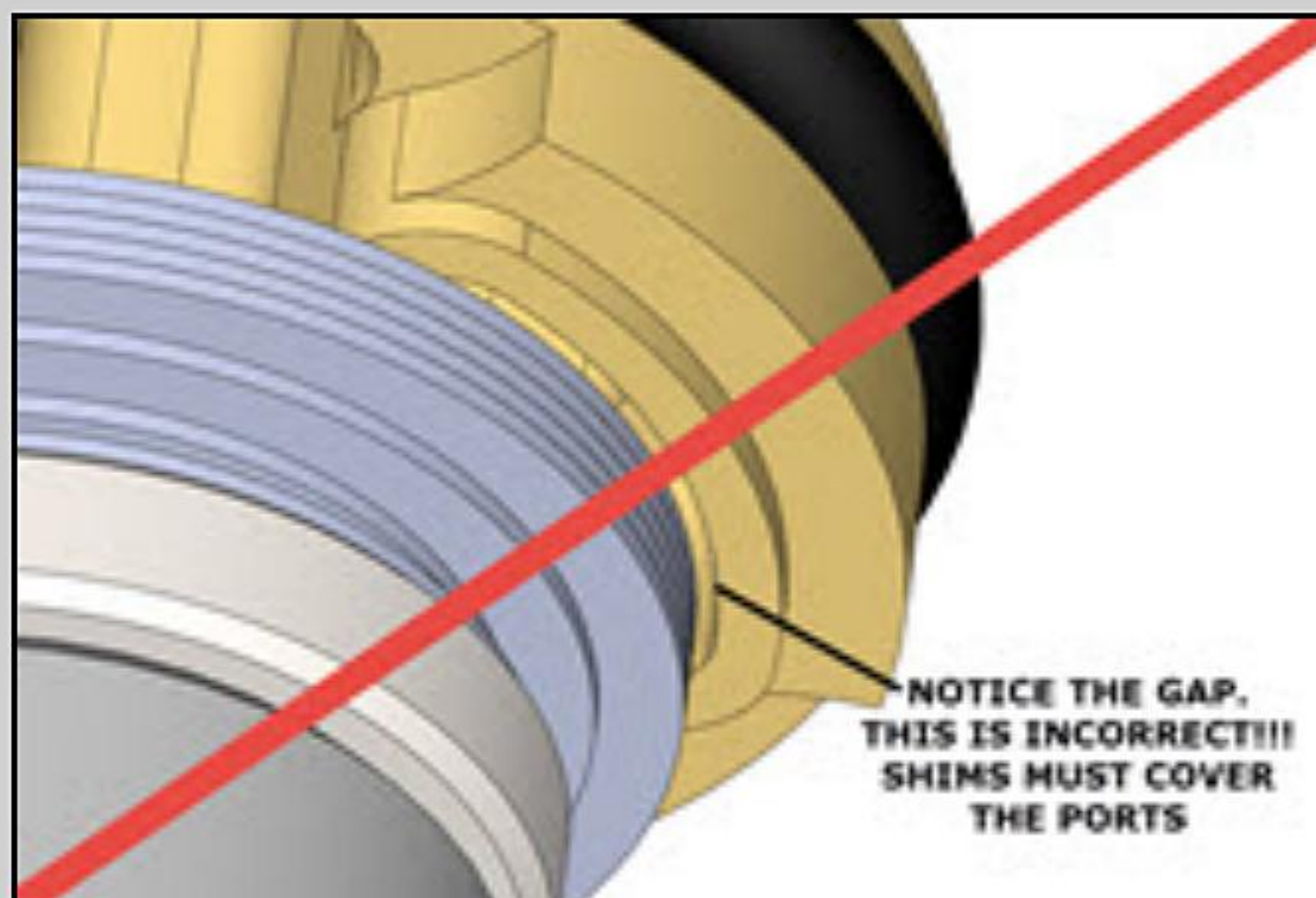

V13- **Make sure the shims that go next to the Gold Valve completely cover the ports on both sides of the piston!** If the ports are not covered there will not be enough damping.

This could be caused by a number of reasons. Piston upside down, Compression and Rebound Stacks reversed on location or installed upside down.

Please call Tech Support if this occurs and you can't figure it out.



V14- Return to the main Rebuild instructions to complete the reassembly.