

RACE TECH

FORK COMPRESSION & REBOUND GOLD VALVE

INSTALLATION HONDA ST1100 & ABS 41 & 43mm FORKS

TOOLS REQUIRED: In addition to the Service Manual along with common hand tools required for disassembly and assembly we recommend; TFSH 10 Shaft Holding Tool, TFBT 1014 Bleed Tool, TFSD 41 or 43 Seal Driver, HI-strength Loctite (included), 400 grit (very fine) or finer Sandpaper.

CAUTION: THIS PROCEDURE SHOULD ONLY BE DONE BY A QUALIFIED SUSPENSION TECHNICIAN. IF YOU ARE NOT FAMILIAR WITH THIS PROCEDURE, STOP! CONTACT RACE TECH OR A QUALIFIED SUSPENSION TECHNICIAN.

DISASSEMBLY

- 1 **Disassemble the forks** and remove the cartridge.
- 2 **Remove the compression valve.** Push the compression valves up into the fork about 25mm (1"). This will allow access to the retaining clips, remove them with a small screwdriver. Next screw the bottom retaining bolt into the base of the valves, pull them out.
- 3 **Remove the rebound rod from the cartridge.** Being very careful not to damage the rod, hold the rod using the TFSH 01 Shaft Holding Tool. The bottom-out piston is held onto the rod with peening over a circlip on the rod (the circlip is not visible until the piston is removed). You must spread the peening over the circlip. Simply tap down on the piston using a hammer and a 300mm (12") length of ½" (12mm) electrical conduit (or some other piece of pipe) as a driver (or you can use a small chisel). This will spread the peening. Save the circlip and piston, they will be reused. Slide the rod out of the cartridge tube.
- 4 **Lightly file the peening off the end of the shaft that holds on the nut.** Remove the nut holding on the rebound valving and **disassemble the valving stack.** Lightly deburr the end of the threads.

VALVING

- 5 **Assemble the Rebound Gold Valve.** There are two types figure 1 and 2. Figure 1 reuses the Special Nut and Wave Washer. Figure 2 uses the cupped washer and check spring. Then install the stock check plate, Rebound Gold Valve (the recess towards the check plate), **r19 rebound shim stack (in supplied shim packs, valving chart on page 4)**, stock base plate and nut. Use Loctite and torque the nut to 30 in-lbs (0.35 kgf-m).

Note: All Gold Valves supplied in this kit come with bleeds PRE-DRILLED

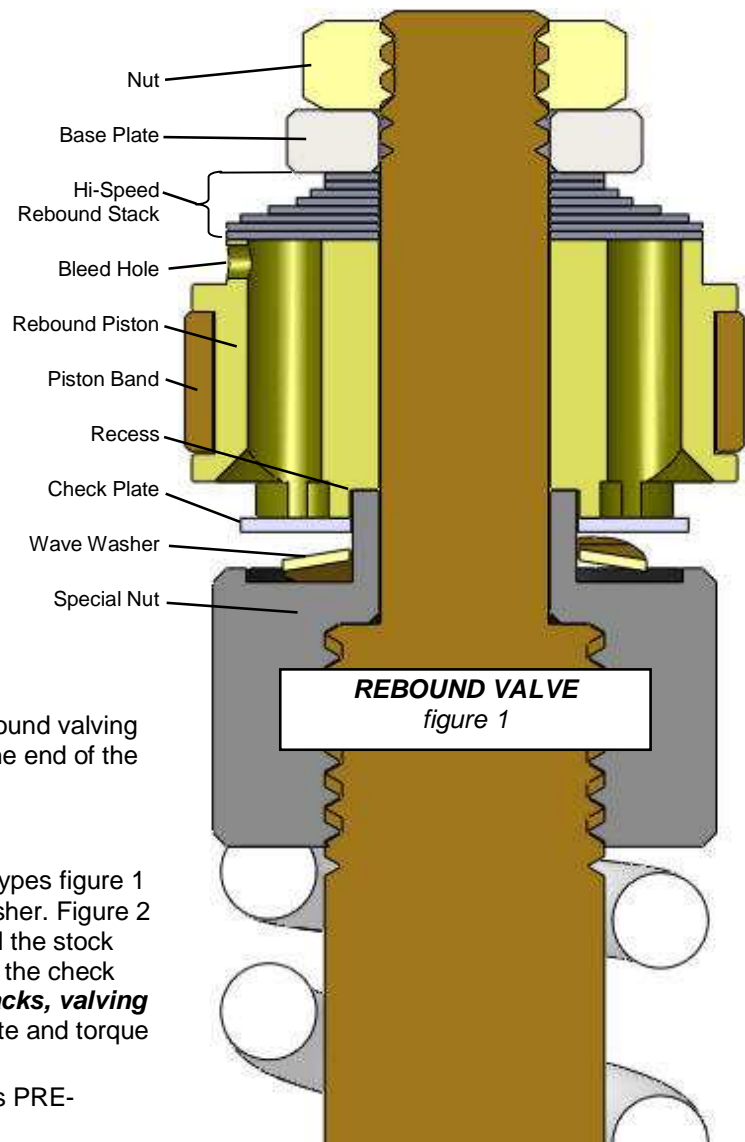

Polish the damping rods with 400 grit (very fine) or finer sandpaper. This will drastically improve bushing life and reduce drag. The important part is the lower half of the rod that contacts the damping rod bushing.

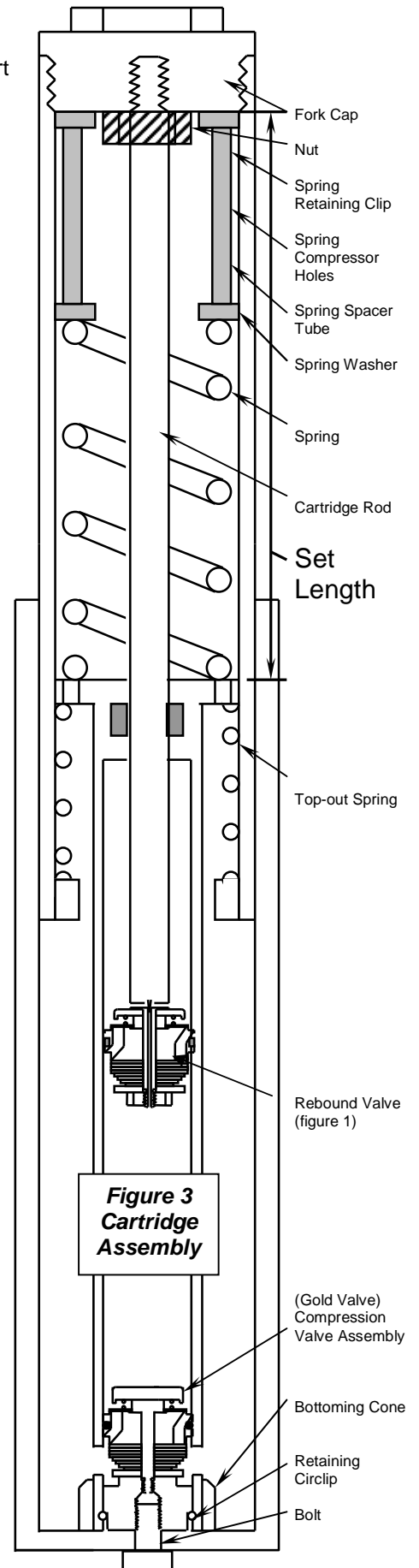
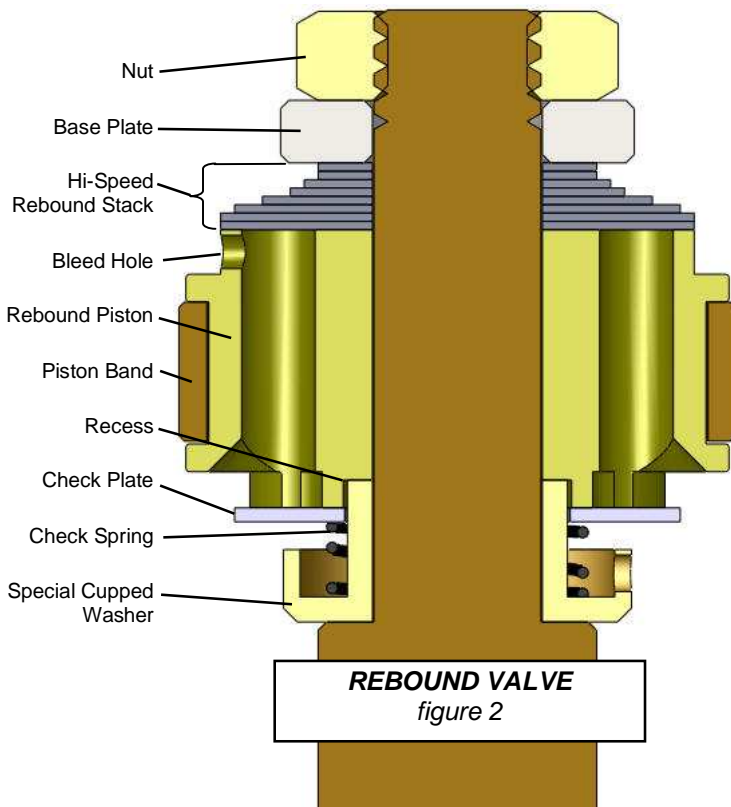
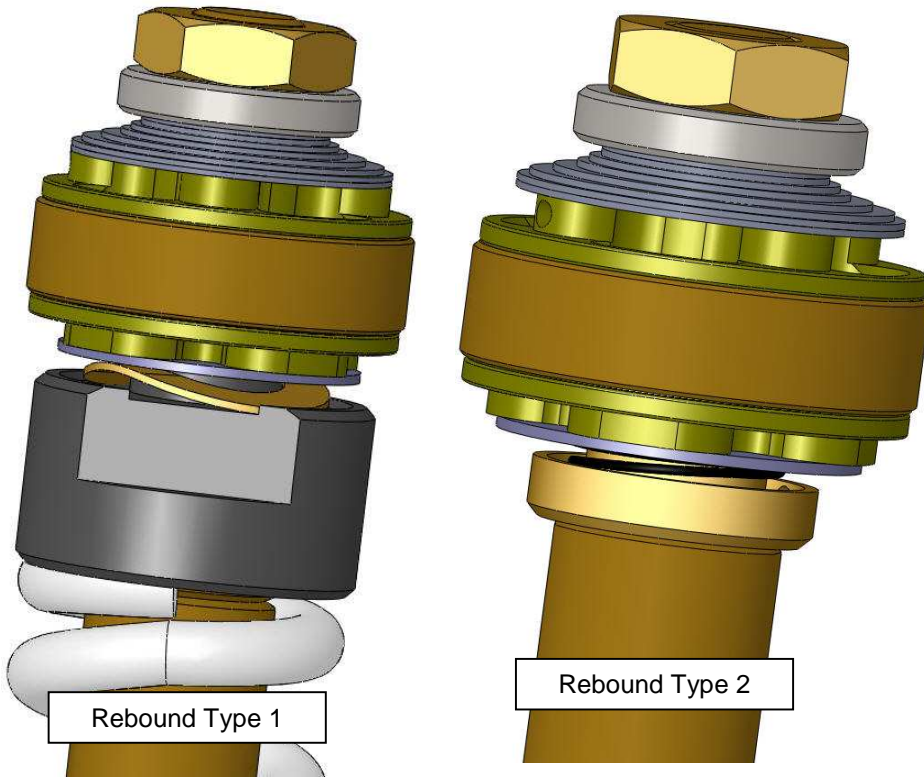

COMPRESSION VALVES

ASSEMBLY

1. **Install the Gold Valve Compression Assembly** into each cartridge. Insert the circlip into the groove, screw the bolt back in and pull to seat the assembly on the circlip.
2. **Reassemble the forks according to your manual.**
3. **Set the fork spring preload.** *Per the instructions in your Race Tech Fork Spring kit.*

Note: You must have washers on both ends of the spacer. The spacer must not rest directly on the spring or the cap. If you are not installing Race Tech Fork Springs reuse the OEM parts in their correct order.

4. **Install the fork fluid.** Pump the cartridge rod using the TFBT 1014 Bleed Tool to bleed the air out.
Set the oil level to 130mm (5.1") using USF-05 Suspension Fluid (5wt) with the fork and cartridge rod completely bottomed and the spring out.
5. **Install Fork spring** with washer, spacer, and washer.
6. **Install the cap on the cartridge rod.** Use Loctite on the damping rod threads at the cap and torque it to manufacturers specs.

This kit is specific to 1991-2002 ST1100 & ABS models. Valving, bleed sizes, etc. are set for these bikes. RT Fork Springs are strongly recommended to realize the full benefit of this kit.

DAMPING ROD LEG - LEFT SIDE

DISASSEMBLY

1. **Remove the damping rod.** An air impact and a long Allen socket helps a lot. For stubborn bolts, use a drift and beat on the head of the damping rod bolt to jar the threads loose.

You will need to remove the Dust Seal, Circlip, Oil Seal, and Bushings as the Damping Rod will not slide out without complete fork leg disassembly. The fork tubes are "slide-hammered" apart after the Circlip is removed. Consult your owner's manual.

On the Damping Rod, remove the 2 large washers at the bottom of the damping rod along with the spring and circlips that retain them. You will not need these for reassembly, leave them out. (anti-dive disabled, no longer necessary)

2. **Enlarge the existing compression holes in the damping rod to 8mm (5/16")** and add additional 8mm holes above the original holes so you end up with six holes (3 sets of 2 holes) (figure 4). When drilling the new holes, space them lengthwise 10mm (.4"). The new set of holes must be 90° to the last set (figure 1). Deburr the compression holes, inside and out. Do not modify the rebound holes.
3. **Check the Emulator Valving.** The standard pre-installed valving is a 64 lb/in Emulator Valve Spring with 4 turns of Valve Spring Preload. Check the tightness of the jam nut on the Emulator.

ASSEMBLY

4. **Reassemble** the fork leg according to your manual. Remember to the top-out spring and aluminum bottom-out cone. Use manufacturers specs for damping rod bolt torque.
5. **Set the fork spring preload** by making the correct length spacer.

Preload is the amount the spring is compressed from fully extended when it is installed.

Set Length is the installed length of the spring (with the fork fully extended).

- A **Measure the Set Length:**

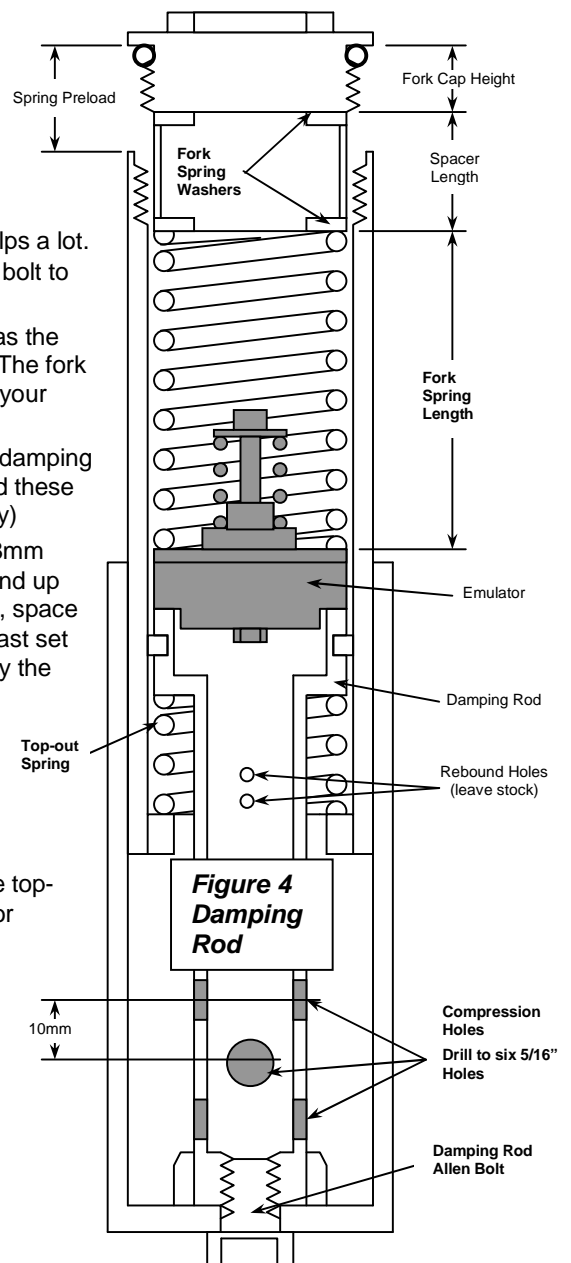

- a. Drop the Emulator down the tube. It sits on top of the damping rod with the Emulator Valve Spring facing up and is held in place with the main fork spring (figure 1). Visually check to make sure the Emulator is sitting squarely on top of the damping rod.
 - b. Extend the fork tube all the way. Use a Tape Measure and measure from the point the spring sits on the top of the Emulator to the top of the fork tube.
 - c. Measure the Cap Height.
 - d. Subtract the Cap Height from the distance to the top of the tube (step b). This is the Set Length.
- B Cut a preload spacer** so the combined length of the spring, spacer and 2 spacer washers is 15mm (.6") longer than the Set Length.
- C Check the Preload.** Insert the fork springs into the fork tube on top of the Emulator. Install a fork spring washer. Place the new spring spacer tube into the fork leg. Then install another washer.
- Set the fork cap on the washer and measure from the top of the fork tube to the sealing lip on the fork cap ("preload" figure 4). This is a direct measurement of fork spring preload for this leg only.
- Note: You must have washers on both ends of the spacer. The spacer must not rest directly on the spring or the cap.
- 6 **Reassemble the forks according to the procedure in your manual.** This will include installation of the Seals and Bushings. It is essential to use a Seal Driver (TFSD 41 or 43) or equivalent for proper installation.
 - 7 **Install the fork fluid.** Bleed the fork by pumping the chrome tube. Install the Emulator and set the oil level to 130mm (5.1") using 10 wt fluid with the fork completely bottomed and the spring out.
 - 8 **Finish reassembly by installing the spring, washers and spacer.** Before you install the cap, re-check the spring preload. This will indicate whether the Emulator is seated properly. Install the fork cap and, with the forks off the bike, push on it, checking for any unusual drag or bind that would indicate an improperly seated Emulator.

FORK INSTALLATION

When the forks are reinstalled on the bike it is very important to **align the fork tubes on the axle** so they won't bind. First, tighten the axle all the way, and then pump the forks with the right-hand axle clamp loose. Finally, tighten the axle clamp.

VALVING CHART REFERENCE - CARTRIDGE LEG

The Compression Stack is on a pre-assembled base valve assembly. Chart provided for reference only. Rebound Stack is contained in the included shim packs. Please verify correct order of shims upon installation at the rebound valve. Page 1, Rebound Valving Installation.

CH34 Compression
(4).15x17
.10x15
.10x13
.10x12
.10x11
.10x10
.10x9

rH19 Rebound
(8).15x17
.10x15
.10x12
.10x9

Shim Dimensions - (QUANTITY) THICKNESS x DIAMETER in mm (for inches divide by 25.4)

EMULATOR TUNING VARIABLES - DAMPING ROD LEG

VARIABLE	Standard	Optional	Primary Effect
Valve Spring Preload*	4 Turns	0 to 7 Turns	Overall firmness, controlling a mushy feel and the speed the front end dives under braking
Oil Viscosity	10wt	USF-05 (5wt) to 20wt	Use oil viscosity to set rebound, this affects traction and stability
Valve Spring Rate	64 lbs/in	26 or 101 lbs/in	Overall firmness and the ride on square shaped bumps

* Measured from zero preload (no tension) on the Valve Spring. To find zero preload back off on the adjuster bolt until the spring is loose then tighten it until the spring just touches. **VALVE IS PRE-SET to 4 TURNS RECOMMENDED SETTING**